

Technical Information

MCHXXX

Control Handle



Revision history

Table of revisions

Date	Changed	Rev
Aug 2025	Deleted device repair chapter, updated the environmental parameters	0801
	Changed document number from 'BC00000033' and '11022667' to 'BC152886483765'	XX
February 2017	MCHXXX Potentiometer Models with 1K Ohm table updated	0601
October 2016	Minor updates	0502
August 2016	Updated to Engineering Tomorrow design	0501
September 2013	Rebranded to Danfoss layout	FA
January 2011	Various updates	EA
May 2010	MCHXXX Potentiometer Models with 1K Ohm table updated	DA
February 2010	MCHXXX Potentiometer Models with 1K Ohm table updated	CA
August 2009	MCHXXX Potentiometer Models with 1K Ohm table updated	BA
January 2009	Corrected operation and storage temperature	AB
December 2008	First edition	AA

Contents

Overview

Description.....	4
Features.....	4

Ordering information

Ordering specification chart.....	5
-----------------------------------	---

Technical data

Specifications.....	8
Environmental testing.....	9

Installation

Dimensions.....	10
Connectors.....	10
Wiring.....	11

Connection diagrams

Potentiometer option	14
Potentiometer option with 1K Ohm potentiometer	14
PWM Option (primarily).....	15
PWM option performance.....	16

Overview

The following topics describe OEM liability and user safety.

Description

The MCHXXX Single Axis Control Handle provides remote electrical actuation of Danfoss pumps/motors, and or other electrically-actuated pump strokers for open loop control systems. The MCHXXX can function as a setpoint for analog or microprocessor-controlled systems for controlling position, speed, pressure, horsepower or other dynamic parameters.

Features

- Shock and vibration resistant
- Choice of three mounting styles, with or without watertight case
- Rugged components designed for the construction environment
- High-torque handle actuation gives sure feel
- Simple to install
- Mechanical options include center-lock, spring-return, friction drag, uni/bi-directionality and optional wire harness with a variety of electrical connectors
- Electrical characteristics customized to the application

Ordering information

Ordering specification chart

A wide range of options to the basic control handle allow custom-tailoring to each application. The following ordering specification chart is provided for assistance in determining model number. Other options are possible, consult Danfoss with further questions.

Ordering specification chart

MCH	X	X	X	X	X	XXX
	Mounting option	Control knob type	Handle actuation	Electrical characteristics	Connector	Factory assigned

Mounting option

Code	Description	Detail
1	Base (surface) mount aluminum case	Four screws connect to the flanges on the bottom of the metal case.
2	Top mount (drop in) with plastic case	Two screws connect to an enlarged mounting plate. Top mounting allows the entire handle to be removed from above the panel. The case is made of black nylon plastic.
3	Top mount (drop in) without case	Two screws connect to an enlarged mounting plate. Top mounting allows the entire handle to be removed from above the panel.
4	Panel mount with plastic case	Four screws connect to the top plate that holds the boot in place. The case is made of black nylon plastic.
5	Panel mount without case	Four screws connect to the top plate that holds the boot in place.

Control knob option

Code	Description	Detail
1	Non-locking	The friction-held handle detents with a spring-loaded ball to indicate null, while the spring-return handle has a spring preload indicating null. The non-locking handle has a standard ball knob.
2	Center lock	The non-locking handle has a standard ball. The center lock handle has a cylindrical knob and provides a positive center lock that unlatches when the operator pulls up on the knob.
3	Non-locking, auxiliary push button switch	This knob is teardrop shaped, with an auxiliary momentary push-button switch on top. The switch is wired through the handle shaft to the body with three wires (common, normally open, and normally closed).
5	Non-locking, no knob	The customer provides customized knob.
6	Three position maintained rocker switch	The cylindrical knob has a boot covering the three-position switch in the knob. The switch, wired through the handle, is used for auxiliary functions.
8*	Special (no handle or knob)	
9	Three position momentary rocker switch	This is the same as option 6, but the switch returns to the center position when released.

* Unique configuration, for details contact your Danfoss representative.

[Reference Dimensions.](#)

Handle actuation option

Code	Description	Detail
A	Spring return, bi-directional	This handle uses a torsion spring to return to the mechanical center position and has 30 degrees of handle throw on either side of center.
B	Friction held, bi-directional	This handle has an adjustable drag, set with a clamp-type brake that holds the handle at the set position and has 30 degrees of handle throw on either side of the center detent.

Ordering information

Handle actuation option (continued)

Code	Description	Detail
C	Friction held, uni-directional	This handle has 60 degrees of high-resolution of handle throw, rotating on only one side of mechanical null, which is at full stroke. It has no detent mechanism.
D	Special (friction held, center detent only, no brake)	

Electrical characteristics option

Code	Description	Detail
A	Proportional, no switches, 12 VDC	This handle's output curve is fairly linear, with output voltage as a function of handle stroke. The supply voltage is 12 Volts, and there are no auxiliary function switches.
B	Proportional, center off switch, 12 VDC,	This handle has a center-off switch that ensures zero output voltage within ± 3 degrees of handle center position.
C	Proportional, center off switch, 24 VDC	Same as option B except this handle runs on a supply voltage of 24 Volts.
D	Proportional, center off and auxiliary switch, 12 VDC	Same as option B except this handle has a second switch that actuates at +2 or -2 degrees.
E	Proportional, set-point potentiometer, 12 VDC	Same as option B except this handle maintains the same polarity of signal in forward or reverse.
F	Step-plus-proportional, 12 VDC	This handle uses two switches to give the step-plus-proportional output current on either side of null. This overcomes deadbands in spool valves (see Specifications on page 8, Step-Plus-Proportional-Control-Handle PWM option illustration). Current beyond this step output is proportional through the rest of the handle throw. Full current output at 30 degrees handle stroke is maximum of 250 mA. Step current is a maximum of 50% of full current output.
G	Step-plus-proportional, 24 VDC	Same as option F, except this handle runs on a supply voltage of 24 Vdc.
H	Switching	This handle is non-proportional. Moving the handle off null activates switches that power ON/OFF devices (for example, solenoid valves).
J	Step-plus-proportional, full auxiliary switching, 12 VDC	This handle uses the step switches for additional secondary functions. Full current output at 30 degrees handle stroke is a maximum of 250 mA. Step current is a maximum of 50% of full current output.
K	Proportional, unwired switch	The customer uses the unwired center switch to operate an auxiliary function, such as neutral start interlock.
L*	Electronic PWM auxiliary switching, 12 Vdc	This handle uses a printed circuit board that makes the step height and output current fully adjustable, accommodating high current applications. It also has pulse width modulation, that dithers the output to overcome hydraulic valve stiction. Full current output at 30 degrees handle stroke is a maximum of 2 Amps into a 5 Ohm load. Step current is a maximum 50% of full current output. Typical dither frequencies (dependent on resistance of the load, specified in the suffix number) are: 60 Hz for the HPI solenoid actuator, approximately 400 Hz for the V7058 Hydrotransmission Valve and approximately 1000 Hz for the MCV101A/MCV116A Pressure Control Pilot Valve.
M	Proportional, three switches	The three switches are: a wired center switch; one unwired switch in forward; and one unwired switch in reverse.
X†	Special (no handle or knob)	
Y†	Special	
Z†	Special	

* Option L, Electronic PWM auxiliary switching, 12 Vdc reached its end of life cycle in 2008 and is no longer available.

† Unique configuration, for details contact your Danfoss representative.

Ordering information

Connector option

Code	Description	Detail
1	Terminal strip	Electrical connections are made to a set of four internal or more screw terminals depending on the specific model.
2	Pigtail 1524 mm [60 in] without connector	Four wires extend from the handle case. Reference Potentiometer option on page 14 for lengths.
3	Pigtail with unsealed Delphi connector	The wires from the case terminate in a Delphi environmental connector. Reference Potentiometer option on page 14.
6	Pigtail with sealed Delphi connector, 4 pin male and female	There are two separate connectors, each connects to a separate potentiometer.
7	Pigtail sealed Delphi connector	The wires from the case terminate in a sealed Delphi connector.
8	Pigtail sealed DEUTSCH connector	The wires from the case terminate in a sealed DEUTSCH connector.

[Pigtail \(or leadwire\) is routed from the control handle to a Delphi environmental connector. Pigtail minimum length is 381 mm \[15 in\].](#)

[For optional connectors, contact your Danfoss representative.](#)

Suffix number

The factory generates these final three numbers. To create the suffix number, supply the following information:

- Supply voltage
- Number of additional switches needed and actuation angle of each with respect to null
- Full current output
- Resistance of the driven load
- Step current needed (if necessary)

[For details regarding unique configurations, contact your Danfoss representative.](#)

Technical data

Specifications

Electrical

Operating voltage	11 to 15 Vdc (12 Volt models)
	22 to 30 Vdc (24 Volt models)
Power*	
Load resistance*	
Switch current capability	3 Amps inductive at 28 Vdc

* Customer specified. Reference [Ordering specification chart](#) on page 5.

Mechanical

Handle stroke	$\pm 30^\circ$
Spring torque	1.2 \pm 0.4 N·m [11 \pm 4 lbf·in] at center breakaway
	2.0 \pm 0.7 N·m [18 \pm 6 lbf·in] at full stroke
Detent torque (over and above friction drag)	1.1 N·m [10 lbf·in]
Friction drag	1.5 \pm 0.3 N·m [13.5 \pm 3 lbf·in] Friction is adjusted at the brake with a 5/32 inch internal hex wrench and 3/8 inch open-end hex wrench.

Step-Plus-Proportional Control Handle: PWM option

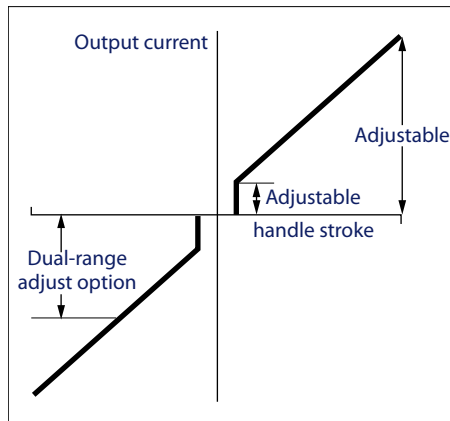

1140B

PWM MCHXXX option reached its end of life cycle in 2008 and is no longer available.

Proportional Control Handle: Potentiometer option

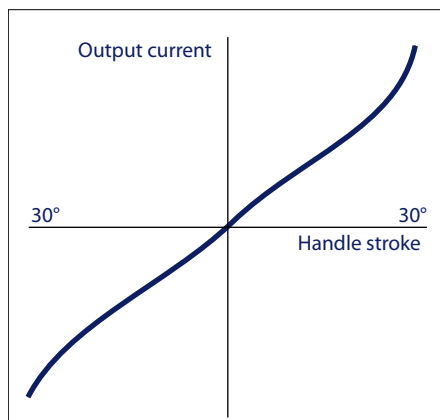

1139A

Technical data

Environmental testing

Temperature	
Operating	-34° to 66°C [-30° to 150°F]
Storage	-40° to 77°C [-40° to 170°F]

Humidity
After being placed in a controlled atmosphere of 95% humidity at 38°C [100°F] for 10 days, the control handle performs normally.

Rain
IP Rating: IP65 (applicable to mounting models #2 and #4 with plastic cases only).

Vibration
Withstands a vibration test designed for mobile equipment controls consisting of two parts: <ol style="list-style-type: none">1. Cycling from 5 to 2000 Hz in each of the 3 axes.2. Resonance dwell for one million cycles for each resonance point in each of the 3 axes.

[NEMA \(National Electrical Manufacturer Association\) NEMA 4 = Intended for indoor or outdoor use primarily to provide a degree of protection against windblown dust and rain, splashing water, hose-directed water and external ice formation.](#)

Installation

Dimensions

MCHXXX Control Handle mounting dimensions in mm [in]

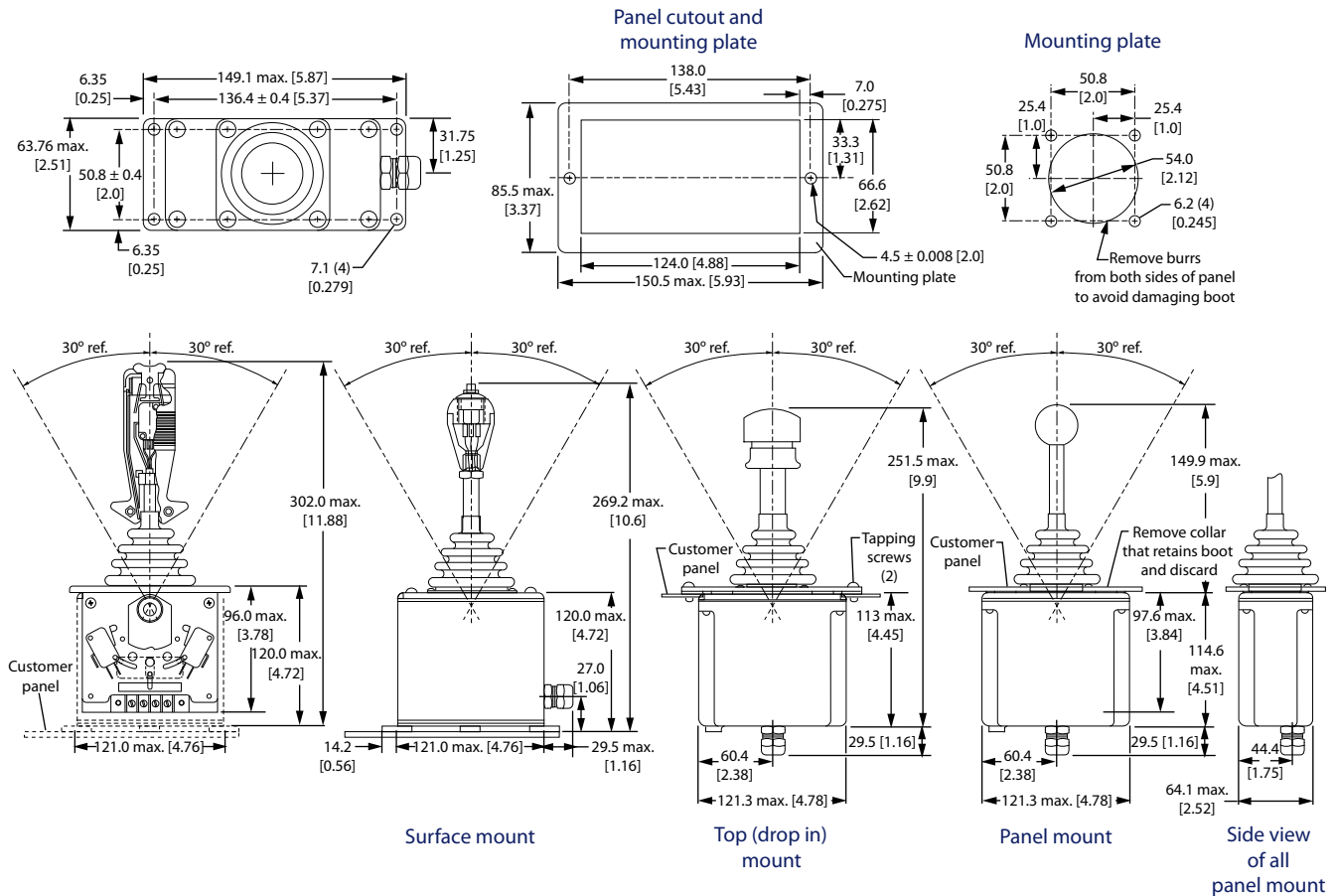

1135D

Connectors

3 or 4 pin Delphi Connector

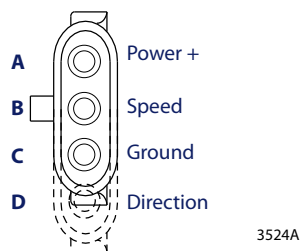

4 pin Deutsch Plug DT Series Connector

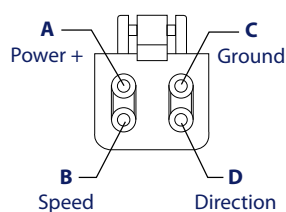

Installation

For optional connectors, contact your Danfoss representative.

Wiring

A barrier terminal strip inside the handle's case provides connections to power, ground, and potentiometers when no external cable is ordered. Run a cable from the strip through the strain relief provided on the side or bottom of the case. Reference [Potentiometer option](#) on page 14. A clockwise handle movement causes a current flow from terminal B to A when the terminal strip is facing you.

Warning

An unforeseen failure may cause an output which could activate a valve or pump. Unexpected vehicle or mechanism movement can endanger people or damage equipment. Handles equipped with a center-off switch will mitigate this condition. When an active neutral is necessary, provide an operator-presence interlock and/or braking system sufficient to stop and hold the system or vehicle.

In most applications, auxiliary switches must be customer-wired, as shown in [Potentiometer option](#) on page 14. When the switch is used as a center-off, power is connected from the external 12 Volt supply to the terminal labeled common. The switch terminals are 3/16 inch quick-connect. [PWM Option \(primarily\)](#) on page 15 shows a pre-wired control handle with center-off switch and Delphi connector, exhibiting the handle phasing and color coding of the wires.

The following illustration shows how to assemble the mating Delphi connector (male shell, female sockets) used in [PWM Option \(primarily\)](#) on page 15.

Delphi mating connector bag assembly (order separately from handle)

Description	Danfoss part number
Six sockets	K03370
One plastic connector body	

Unsealed Delphi mating connector assembly

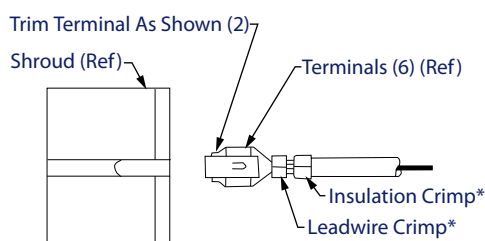

* Crimp before inserting terminal into body

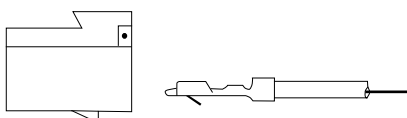

1137B

For optional connectors, contact your Danfoss representative.

PWM MCHXXX option models are fitted with trim potentiometers for adjusting the output current. The following illustration shows the location of the three trim potentiometers on the L handle. There are either 3 or 4 trim potentiometers depending on the specific MCHXXX model. Reference [Ordering specification chart](#) on page 5, Electrical characteristics option table, Code M—Proportional, three switches.

Installation

Caution

Overcurrent could damage the control handle. Use a 1 Amp fuse in series for applications with low current requirements to avoid damaging the control handle.

MCHXXX PWM option with trim potentiometer configurations

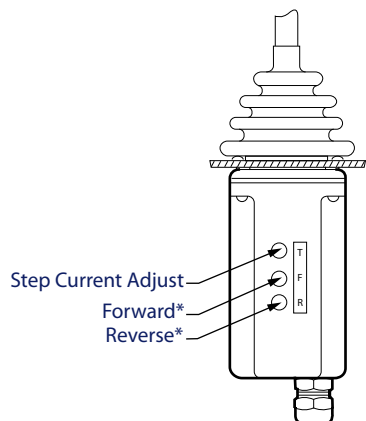

* Span adjust or full current output

1138B

Handle adjustments

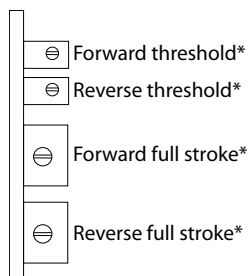

* Clockwise increases output

2382

PWM MCHXXX option reached its end of life cycle in 2008 and is no longer available.

L control handles

Standard L	Threshold adjustment Counter clockwise increases output	
	Forward full stroke Clockwise increases output	
	Reverse full stroke Clockwise increases output	
L with (2) threshold adjustments	Forward threshold Counter clockwise increases output	
	Reverse threshold Clockwise increases output	
	Forward full stroke Clockwise increases output	
	Reverse full stroke Clockwise increases output	

Installation

L control handles (continued)

L with acceleration/ deceleration Ramp	Threshold adjustment Counter clockwise increases output	
	Forward full stroke Clockwise increases output	
	Reverse full stroke Clockwise increases output	
	Acceleration/deceleration ramp Clockwise increases time	

Option L, Electronic PWM auxiliary switching, 12 Vdc reached its end of life cycle in 2008 and is no longer available.

Connection diagrams

Potentiometer option

Direct EDC Control

Center-off switch assembly and wiring connections for the control handle.

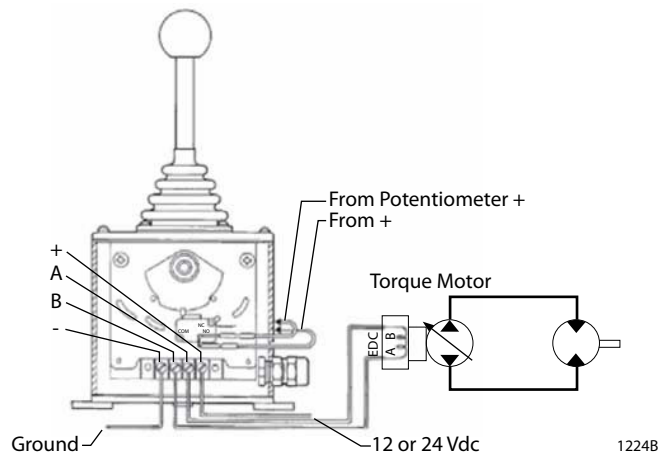

MCHXXX potentiometer models having either two or single 200 Ohm pots are configured to directly control Danfoss variable pumps with electrical displacement controls (EDCs). Whether two or single pots, both require the same electrical connection to the EDC and only one of the dual coils needs to be connected to achieve forward and reverse pump flow.

Potentiometer option with 1K Ohm potentiometer

Analog setpoint controller input

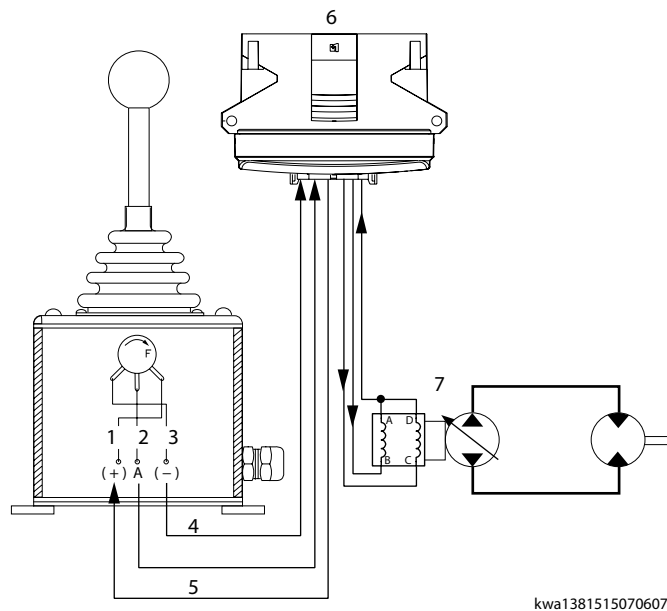

- | | |
|-----------|-----------------------|
| 1. Red | 5. 5 Vdc supply |
| 2. Green | 6. PLUS+1® controller |
| 3. Black | 7. Torque motor |
| 4. Ground | |

Connection diagrams

MCHXXX potentiometer models having a 1K Ohm pot are commonly used as analog input to a controller (for example, SX or PLUS+1® MC200 Controllers). The supply voltage (5 VDC sensor supply) is usually supplied from the controller.

MCHXXX potentiometer models typically used for a PLUS+1® input

Material number	Model code	Centerlock	Spring return	Friction hold	5 Vdc supply	Terminal strip	Microswitches		
							Forward	Neutral	Reverse
11090431	MCH19AM1649 Rocker 3-pos momentary		X		X	X	X	X	X
	MCH11CB1510			X	X	X	X		
11046484	MCH12AR1642	X	X		X	X	X		X
10106017	MCH21CB1510			X	X	X	X		
11048497	MCH22AA1644	X	X		X	X			
11147104	MCH22AB1648	X	X		X	X		X	
11068164	MCH22BB1648	X		X	X	X		X	
11181083	MCH41BB1648			X	X	X		X	
	MCH41BM1504			X	X	X	X	X	X
	MCH41AB1648		X		X	X		X	
11068165	MCH42BB1644	X		X	X	X		X	
	MCH51AM1497		X		X	X	X	X	X
11017769	MCH51BB1535			X	X	X		X	
	MCH51BD1517			X	X	X		X	
	MCH52BM1497			X	X	X	X	X	X

PWM Option (primarily)

PWM MCHXXX option reached its end of life cycle in 2008 and is no longer available.

Phasing and color scheme for handle with cable and connector

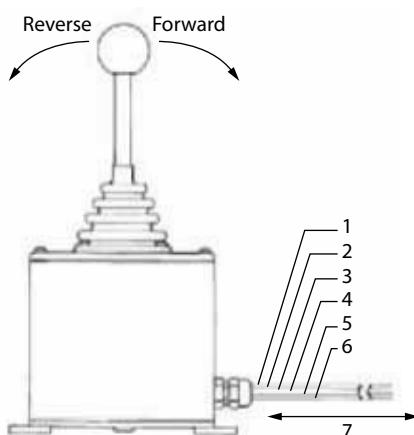

toi1476734361490

1.	Blue	Powered when handle is centered	5.	White	Valve drive, handle reverse
2.	Red	12 or 24 Vdc supply	6.	Black	Ground
3.	Yellow	Powered when handle is off center	7.	304.80 mm	Cable length with connector
4.	Green	Valve drive, handle forward		1524.00 mm	Cable length without connector

The blue and yellow wires provide optional functions.

Connection diagrams

PWM option performance

Null current	±5 mA maximum if not switched (12 Vdc models)
	±8 mA maximum if not switched (24 Vdc models)
Center deadband (optional)	±3° nominal
Full stroke current capability*	
Step current	Step current occurs at end of deadband.

* Customer specified. Reference Ordering Information.

Products we offer:

- Cylinders
- Electric converters, machines, and systems
- Electronic controls, HMI, and IoT
- Hoses and fittings
- Hydraulic power units and packaged systems
- Hydraulic valves
- Industrial clutches and brakes
- Motors
- PLUS+1[®] software
- Pumps
- Steering
- Transmissions

Danfoss Power Solutions designs and manufactures a complete range of engineered components and systems. From hydraulics and electrification to fluid conveyance, electronic controls, and software, our solutions are engineered with an uncompromising focus on quality, reliability, and safety.

Our innovative products makes increased productivity and reduced emissions a possibility, but it's our people who turn those possibilities into reality. Leveraging our unsurpassed application know-how, we partner with customers around the world to solve their greatest machine challenges. Our aspiration is to help our customers achieve their vision — and to earn our place as their preferred and trusted partner.

Go to www.danfoss.com or scan the QR code for further product information.

**Hydro-Gear**

www.hydro-gear.com

Daikin-Sauer-Danfoss

www.daikin-sauer-danfoss.com

**Danfoss
Power Solutions (US) Company**
2800 East 13th Street
Ames, IA 50010, USA
Phone: +1 515 239 6000

**Danfoss
Power Solutions GmbH & Co. OHG**
Krokamp 35
D-24539 Neumünster, Germany
Phone: +49 4321 871 0

**Danfoss
Power Solutions ApS**
Nordborgvej 81
DK-6430 Nordborg, Denmark
Phone: +45 7488 2222

**Danfoss
Power Solutions Trading
(Shanghai) Co., Ltd.**
Building #22, No. 1000 Jin Hai Rd
Jin Qiao, Pudong New District
Shanghai, China 201206
Phone: +86 21 2080 6201

Danfoss can accept no responsibility for possible errors in catalogues, brochures and other printed material. Danfoss reserves the right to alter its products without notice. This also applies to products already on order provided that such alterations can be made without subsequent changes being necessary in specifications already agreed. All trademarks in this material are property of the respective companies. Danfoss and the Danfoss logotype are trademarks of Danfoss A/S. All rights reserved.