



HY1

EXTERNAL GEAR PUMP GROUP 1

From 1 to 9.5 cc/rev
Up to 260 bar



TECHNICAL CATALOGUE

Hydreco is pleased to introduce a brand new range of gear pumps and motors. Based on the experience and knowledge acquired over many years of engineering and manufacturing, the HY series is provided with an aluminum alloy housing, two gear wheels supported by sleeve bearings and cast iron flange and cover.

The HY1 series, available as pumps and motors, offers high efficiency, low noise level and can be applied in standard and heavy duty application, thanks to the high reliability and the accuracy of design and production. The pumps can be supplied as single, or as multiple units with a huge variety of options and flanges, shafts and ports, providing the right setup on each application. Feel free to contact your Hydreco representative to find out and to get the proper support in your selection.

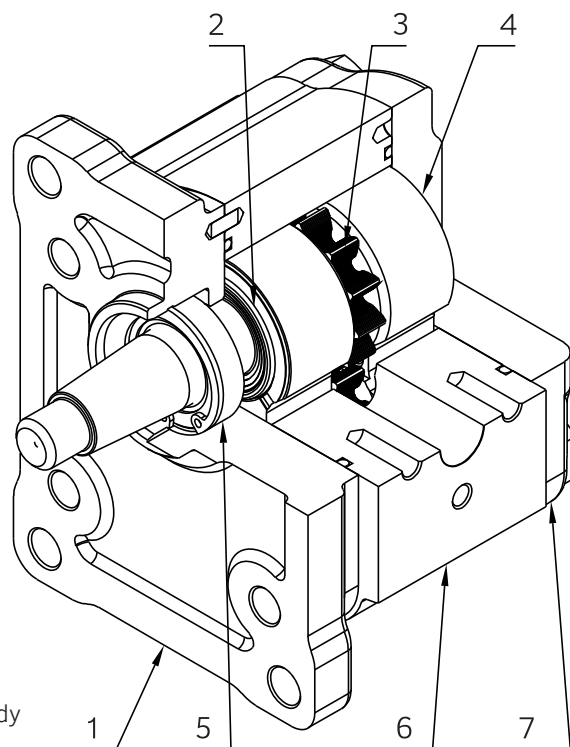

Displacements

From 1 cm³/rev to 9.5 cm³/rev
From 0.06 in³/rev to 0.58 in³/rev

Pressures

Max continuous 260 bar (3770 psi)
Max intermittent 280 bar (4060 psi)
Max peak 300 bar (4350 psi)

Max Speed

4000 rpm



- H1300P002C = Pump / Motor part number
- P C015+015+019-E10T1 = Abbreviate model code
Ex. Triple pump 1.5cc+1.5cc+1.9cc - European Standard Clockwise
- C21 1544 = Serial number - Ex. C (month) - 21 (year) - 0189 (Production order)
- 1544 (identification num.)
- Arrow = Direction of rotation
- QR CODE = Complete model code

ORDERING CODE IDENTIFICATION FOR SINGLE PUMPS

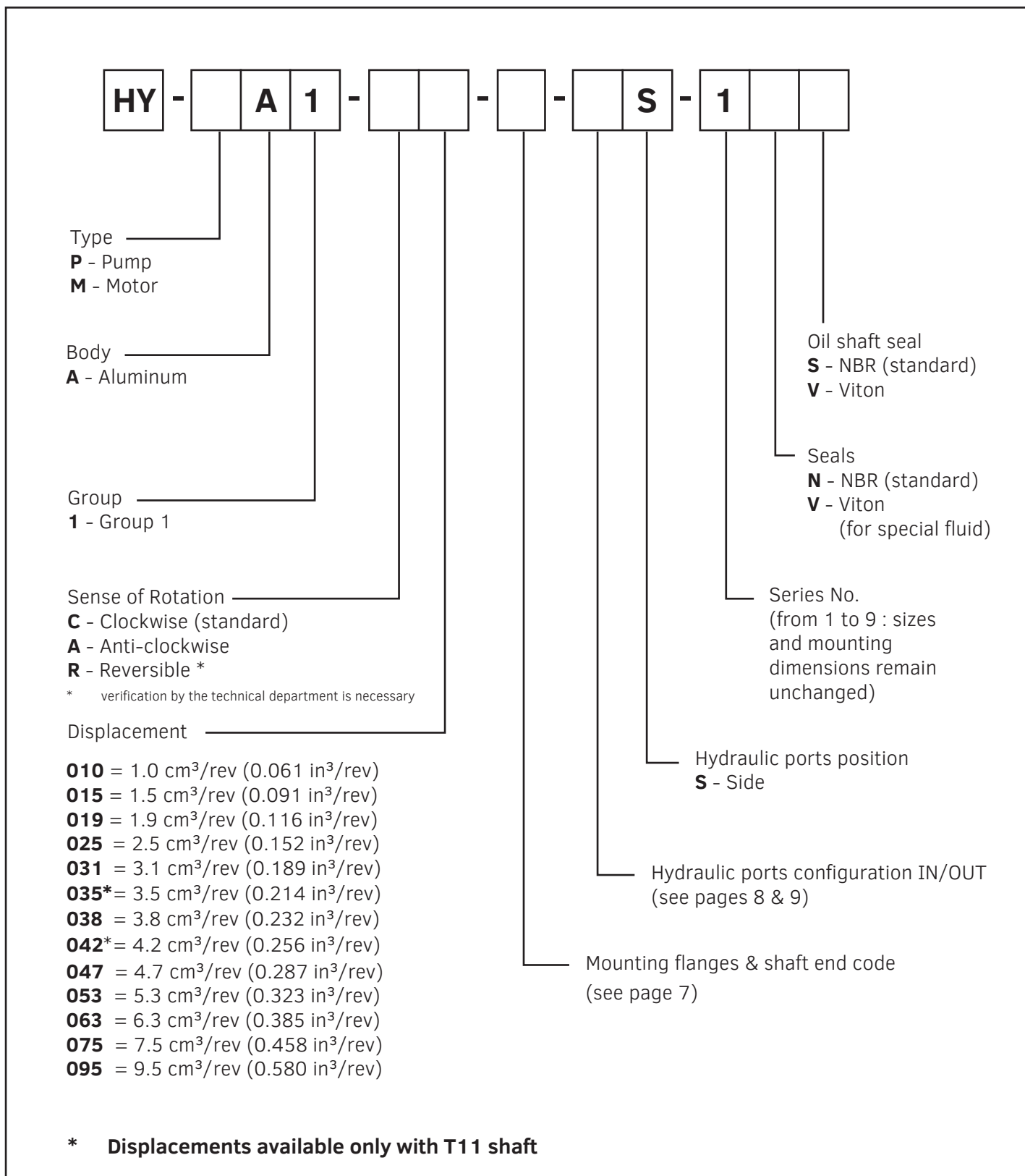

Example

HY-PA1-C015-E10T1-FG2/2S-1NS

Single pump GR1 - clockwise rotation - European flange with tapered shaft 1:8 - German flanged ports

ORDERING CODE IDENTIFICATION FOR MULTIPLE PUMPS

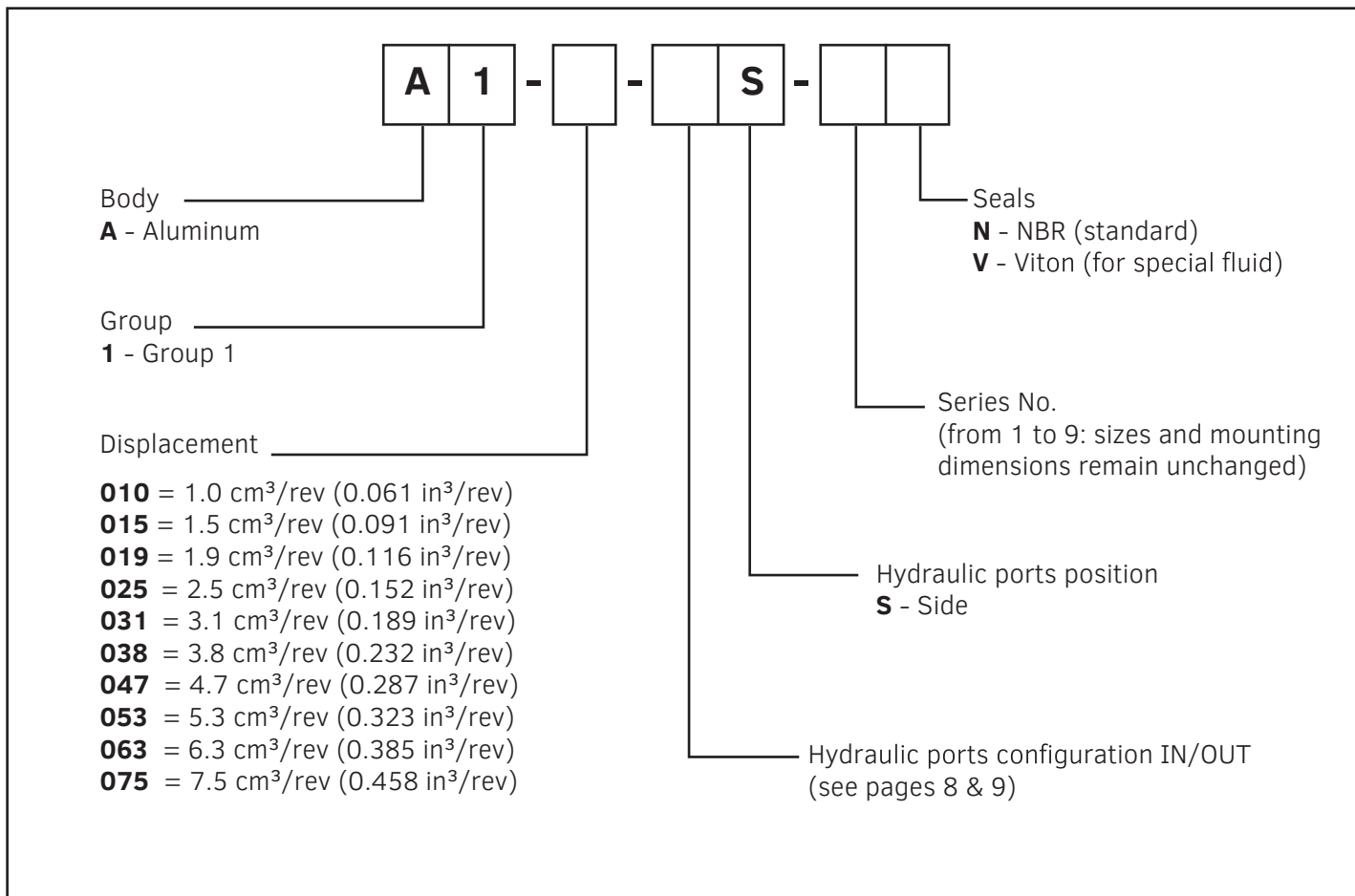

Example

HY-PA1-C015-E10T1-FG2/2S-1NS+A1-015-FG2/2S-1N

GR1 double pump - clockwise rotation - European flange with tapered shaft 1:8 - German flanged ports

GROUP	SIZE	DISPLACEMENT cm ³ /rev (in ³ /rev)	WEIGHT Kg	MAX PRESSURE bar (psi)			SPEED rpm	
				P1	P2	P3	min	max
HY1	010	1.0 (0.061)	1.35	250 (3620)	270 (3920)	290 (4200)	650	4000
	015	1.5 (0.091)	1.35	260 (3770)	280 (4050)	300 (4350)		
	019	1.9 (0.116)	1.40					
	025	2.5 (0.125)	1.40					
	031	3.1 (0.189)	1.40					
	035	3.5 (0.214)	1.45					
	038	3.8 (0.232)	1.45					
	042	4.2 (0.256)	1.45					
	047	4.7 (0.287)	1.50	240 (3480)	260 (3770)	280 (4050)		
	053	5.3 (0.323)	1.55					
	063	6.3 (0.385)	1.60					
	075	7.5 (0.458)	1.65	180 (2610)	220 (3190)	240 (3480)	3500	
	095	9.5 (0.580)	1.80	140 (2030)	180 (2610)	200 (2900)	3000	

The data in the table refer to unidirectional pumps and motors.
 The maximum pressures of reversible pumps and motors are 15% lower than unidirectional ones.

For different working conditions please contact Hydreco Technical Support.

GENERAL CHARACTERISTICS

ROTATION DIRECTION

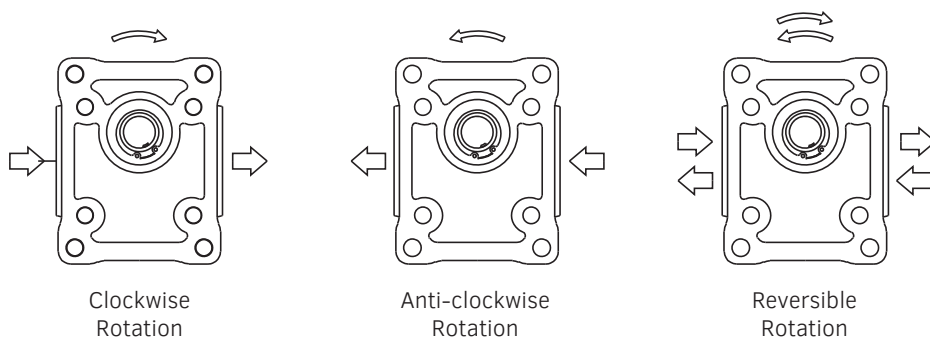

DEFINITION OF PRESSURES

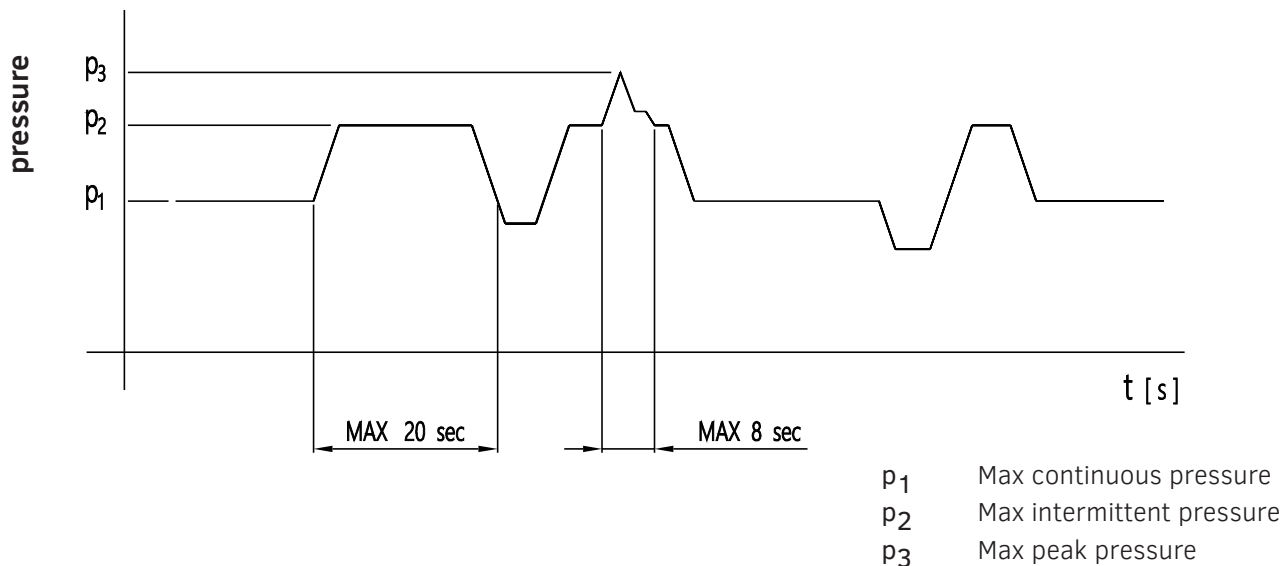

GENERAL CHARACTERISTICS

It is essential that pumps are installed so that they can always fill with fluid. 'HY' Series pumps inlet porting is designed to facilitate full volume fill but the following machine design recommendations should be followed.

Direction of rotation (Viewed from shaft end)	Clockwise (C) – Anticlockwise (A) – Reversible (R)
Range inlet pressure – pump	0.7 ÷ 3 bar (10 ÷ 43 psi)
Max back pressure on the unidirectional motors and reversible with internal drainage	P ₁ (continue) max 5 bar (72 psi) P ₂ (for 20 sec) max 8 bar (115 psi) P ₃ (for 5 sec) max 15 bar (215 psi)
Reversible Motor Max pressure in drain	5 bar
Temperature fluid (MIN, MAX, PEAK) °C	-25, 80, 100 NBR -25, 110, 125 VITON
Range of viscosity	From 10 to 100 mm ² /s (cSt) IDEAL Up to 750 mm ² /s (cSt) RECOMMENDED Up to 1000 mm ² /s (cSt) START
Fluid type	Mineral oil

RECOMMENDED FILTRATION

Working pressure bar (psi)	$\Delta p < 140$ (2030)	140 (2030) < $\Delta p < 210$ (3040)	$\Delta p > 210$ (3040)
Class contamination NAS 1638	10	9	8
Class contamination ISO 4406:1999	21/19/16	20/18/15	19/17/14

- Q = flow rate (L/min)
- V = displacement (cm³/rev)
- n = speed (min⁻¹)
- M = torque (Nm)
- P = power (kW)
- Δp = pressure (bar)

	PUMPS	MOTORS
--	--------------	---------------

PERFORMANCE

η_v = volumetric efficiency	≈ 0.96	≈ 0.95
η_{hm} = hydro-mechanical efficiency	≈ 0.88	≈ 0.85
η_t = total efficiency	≈ 0.84	≈ 0.81

DETERMINATION OF A PUMP

$$Q_{\text{theor}} = \frac{V \times n}{1000} \text{ (l/min)} \quad Q_{\text{real}} = Q_{\text{theor}} \times \eta_v$$

$$M_{\text{real}} = \frac{M_{\text{theor}}}{\eta_{\text{hm}}} \text{ (Nm)} \quad M_{\text{theor}} = \frac{\Delta p \times V}{62.8} \text{ (Nm)}$$

$$P_{\text{OUT}} = \frac{\Delta p \times Q}{600} \text{ (kW)} \quad P_{\text{IN}} = \frac{P_{\text{OUT}}}{\eta_t}$$

DETERMINATION OF A MOTOR

$$Q_{\text{theor}} = \frac{V \times n}{1000} \text{ (l/min)} \quad Q_{\text{real}} = \frac{Q_{\text{theor}}}{\eta_v}$$

$$M_{\text{theor}} = \frac{\Delta p \times V}{62.8} \text{ (Nm)} \quad M_{\text{real}} = M_{\text{theor}} \times \eta_{\text{hm}}$$

$$P_{\text{OUT}} = \frac{\Delta p \times Q}{600} \text{ (kW)} \quad P_{\text{IN}} = P_{\text{OUT}} \times \eta_t$$

PUMP SELECTION

Curves at 40°C – fluid viscosity 46 mm²/sec

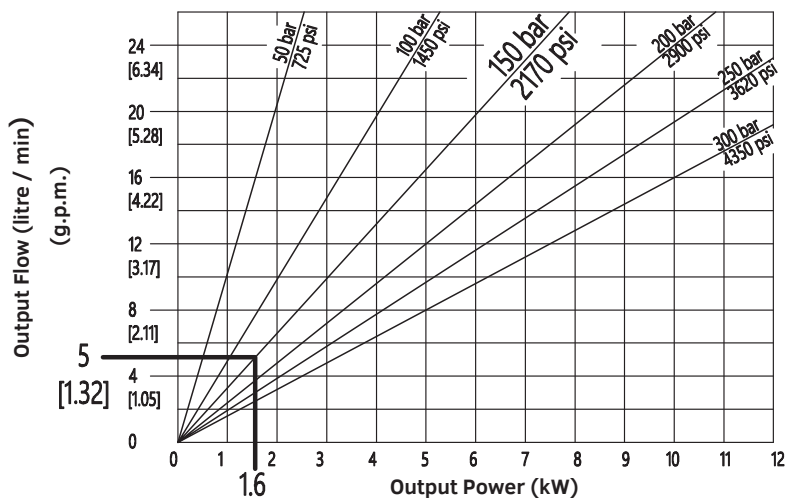
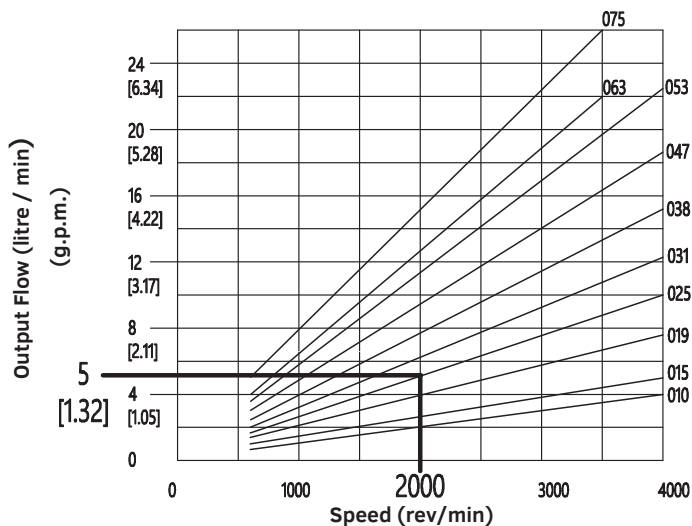

Example

Working conditions:
 Pump 2.5cc
 Speed 2000 r.p.m.
 Pressure: 150 bar [2170 psi]
 Motor: 1.6 kW

NOTE:

Diagrams provide approximate selection data

OUTPUT FLOWS are theoretical.

Generally volumetric efficiencies are in excess of 95%.

Please contact your Hydreco representative for specific working conditions.

INPUT POWERS are theoretical taking into account average efficiencies.

EUROPEAN standard CODE	FLANGE	SHAFT
E10T1	E10 = European flange pilot Ø25.4	T1 = Tapered shaft 1:8 - M7x1
E10T11	E10 = European flange pilot Ø25.4	T11 = Tapered shaft 1:8 - M10x1
E11T1	E11 = European flange pilot Ø25.4 Oval Holes	T1 = Tapered shaft 1:8 - M7x1
E11T11	E11 = European flange pilot Ø25.4 Oval Holes	T11 = Tapered shaft 1:8 - M10x1
E12T11	E11 = European flange pilot Ø30	T11 = Tapered shaft 1:8 - M10x1

AMERICAN standard CODES	FLANGE	SHAFT
AA012P	AA = American flange SAE AA 2 bolts	012P = SAE AA 1/2 Parallel

For other configurations than those indicated, please contact Hydreco technical support.

FLANGES OPTIONS

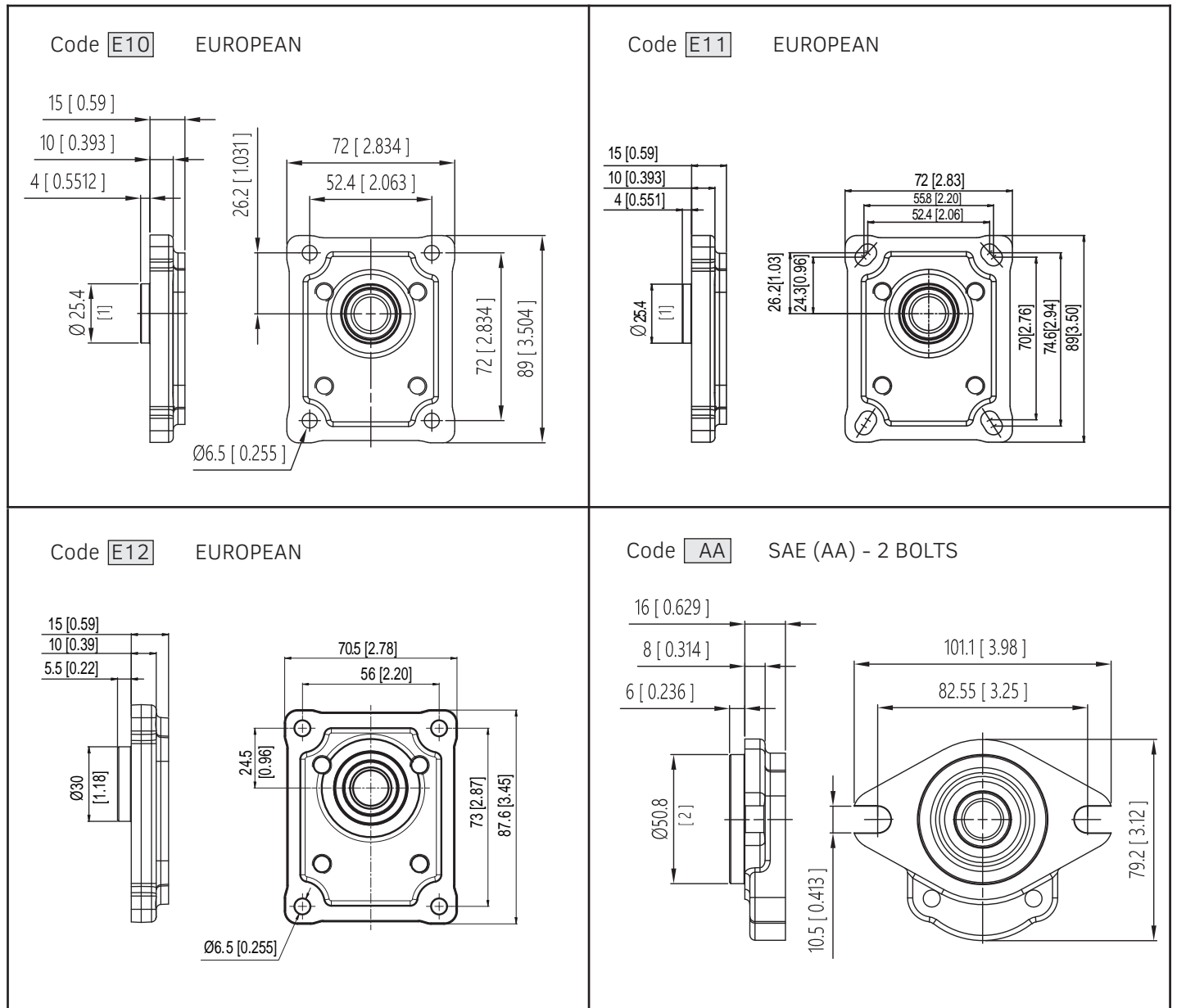

SHAFTS OPTIONS

<p>Code T1 European Tapered 1:8</p> <p>Max Torque = 20 Nm (177 lbf in)</p>	<p>Code T11* European Tapered 1:8</p> <p>*Shaft available for displacements : 025 - 031 - 035 - 038 - 042 - 053 Max Torque = 90 Nm (797 lbf in)</p>
<p>Code 012P SAE (AA) 1/2" Parallel</p> <p>Max Torque = 30 Nm (266 lbf in)</p>	

For different displacements, please contact Hydreco Technical Support.

SHAFT OIL SEAL

Code **T1** = **12 x 22 x 7**

Code **T11** = **14 x 22 x 7**

Code **012P** = **13 x 22 x 7**

PORTS OPTIONS

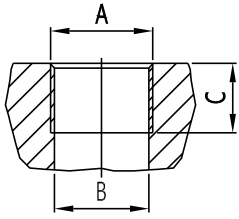
BSPP THREADED PORTS (B) Compliant with ISO 228 	Ordering Code	Dimension mm (inches)			Tightening Torque Nm [lbf in]	
		A	B	C	Low Pressure	High Pressure
15	3/8"	15 (0.59)	12 (0.472)	15 [130]	25 [220]	
2	1/2"	19 (0.748)	14 (0.551)	20 [180]	50 [440]	

STANDARD PORT CONFIGURATION				
CODE	SUCTION	PRESSURE	POSITION	SIZE
B15/15S	3/8" BSPP	3/8" BSPP	side	010 to 031
B2/15S	1/2" BSPP	3/8" BSPP	side	038 to 095

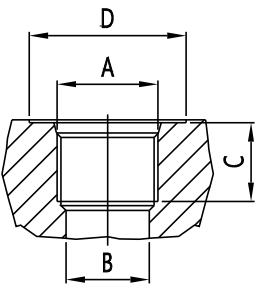
SAE THREADED PORTS (U) Compliant with SAE J514 	Ordering Code	Dimensions mm (inches)				Tightening Torque Nm [lbf in]	
		A	B	C	D	Low Pressure	High Pressure
15	9/16" - 18 UNF	13 (0.511)	15 (0.590)	26 (1.023)	15 [135]	25 [220]	
2	3/4"-16 UNF	17 (0.669)	15 (0.590)	32 (1.259)	20 [180]	45 [400]	

STANDARD PORT CONFIGURATION				
CODE	SUCTION	PRESSURE	POSITION	SIZE
U2/15S	3/4" - 16 UNF	9/16"-18 UNF	side	010 to 095

INLET PORTS = For multiple pumps with single inlet please contact Hydreco Technical Support.

'U' PORTS ARE AVAILABLE ONLY FOR QUANTITIES OF AT LEAST 50 PIECES/CODE

EUROPEAN FLANGED PORTS (FE)	Ordering Code	Dimensions mm (inches)			Tightening Torque Nm [lbf in]	
		A	B	C	Low Pressure	High Pressure
	2	13 (0.511)	30 (1.181)	M6	8 [70]	8 [70]
	15	10 (0.394)	26 (1.024)	M5	8 [70]	8 [70]

STANDARD PORT CONFIGURATION				
CODE	SUCTION	PRESSURE	POSITION	SIZE
FE2/2S	Ø13 mm	Ø13 mm	side	Only 038 to 053
FE15/15S	Ø10 mm	Ø10 mm	side	Only 010 to 025

'FE' PORTS FOR DIFFERENT DISPLACEMENTS ARE AVAILABLE FOR QUANTITIES OF MINIMUM 50 PIECES PER P/N

GERMAN FLANGED PORTS (FG)	Ordering Code	Dimensions mm (inches)			Tightening Torque Nm [lbf in]	
		A	B	C	Low Pressure	High Pressure
	2	13 (0.511)	30 (1.181)	M6	8 [70]	8 [70]

STANDARD PORT CONFIGURATION				
CODE	SUCTION	PRESSURE	POSITION	SIZE
FG2/2S	Ø13 mm	Ø13 mm	side	all

INLET PORTS = For multiple pumps with single inlet please contact Hydreco Technical Support.

UNIDIRECTIONAL PUMPS / MOTORS

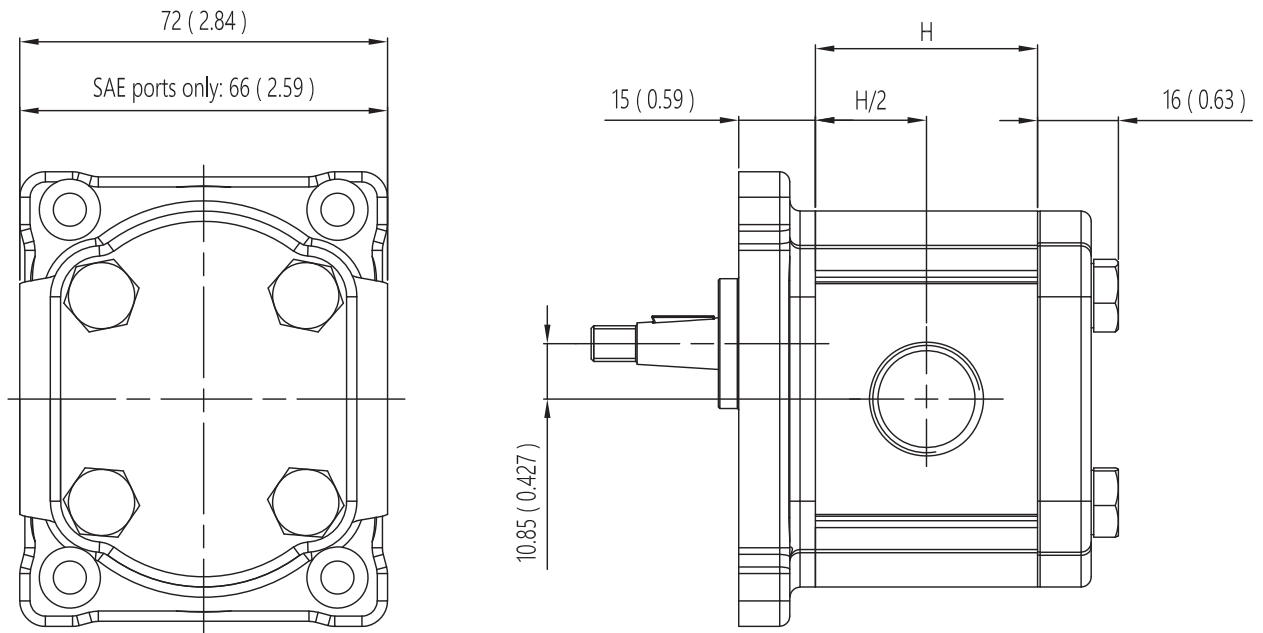

REVERSIBLE PUMPS / MOTORS

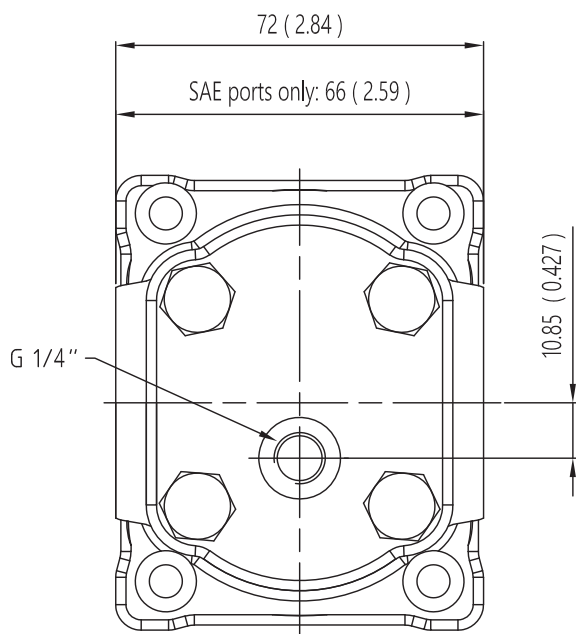

GROUP	SIZE	H mm (inch)	WEIGHT kg (lbs)
HY1	010	35.7 (1.405)	1.45 (3.20)
	015	37.5 (1.476)	1.45 (3.20)
	019	39.0 (1.535)	1.50 (3.31)
	025	41.3 (1.626)	1.50 (3.31)
	031	43.5 (1.712)	1.50 (3.31)
	035	45.0 (1.772)	1.53 (3.37)
	038	46.1 (1.814)	1.55 (3.42)
	042	47.5 (1.870)	1.57 (3.46)
	047	49.5 (1.949)	1.60 (3.53)
	053	51.7 (2.035)	1.65 (3.64)
	063	55.5 (2.180)	1.70 (3.75)
	075	59.2 (2.330)	1.75 (3.86)
095	68.0 (2.677)	1.85 (4.08)	

TANDEM PUMPS

Standard configuration

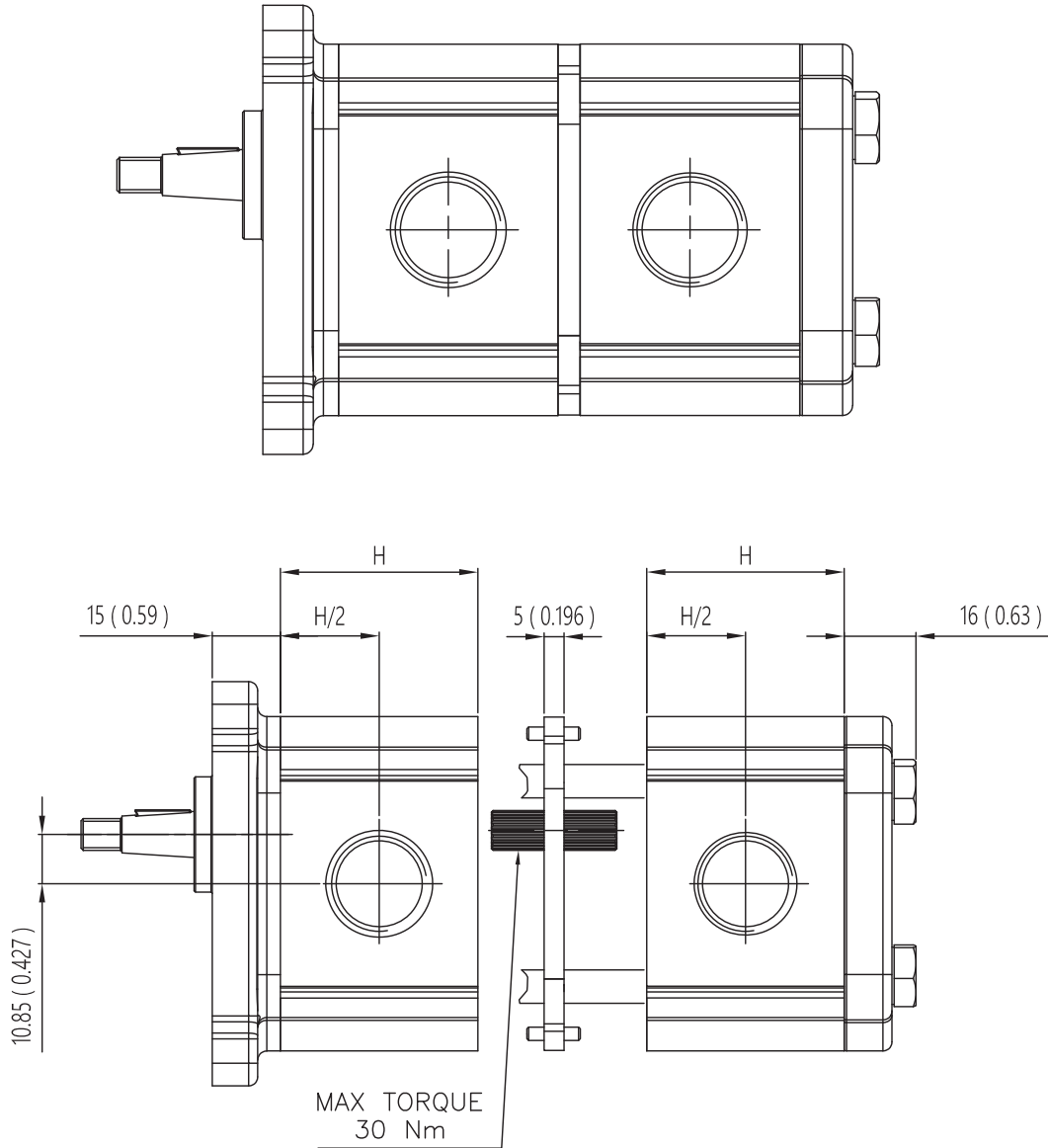

GROUP	SIZE	H mm (inch)	WEIGHT kg (lbs)
HY1	010	35.7 (1.405)	1.10 (2.43)
	015	37.5 (1.476)	1.10 (2.43)
	019	39.0 (1.535)	1.15 (2.54)
	025	41.3 (1.626)	1.15 (2.54)
	031	43.5 (1.712)	1.15 (2.54)
	035	45.0 (1.772)	1.15 (2.54)

GROUP	SIZE	H mm (inch)	WEIGHT kg (lbs)
HY1	038	46.1 (1.814)	1.20 (2.65)
	042	47.5 (1.870)	1.25 (2.76)
	047	49.5 (1.949)	1.25 (2.76)
	053	51.7 (2.035)	1.30 (2.87)
	063	55.5 (2.180)	1.35 (2.98)
	075	59.2 (2.330)	1.40 (3.09)

TANDEM PUMPS SCREW LENGTHS

SIZE cc Gr.1	010	015	019	025	031	038	047	053	063	075
010	100	105	105	105	110	110	115	115	120	125
015		105	105	110	110	115	110	120	125	125
019			105	110	110	115	120	120	125	130
025				110	115	115	120	125	125	130
031					115	120	125	125	130	130
038						120	125	125	130	135
047							130	130	135	140
053								135	135	140
063									140	145
075										150

TANDEM PUMPS HY1+HY1
M8 screws size
10.9 screws class
Screws Tightening Torque = 29 +/- 1 Nm
Length expressed in millimeters

EXAMPLES WITH COMMON INLET (top view)

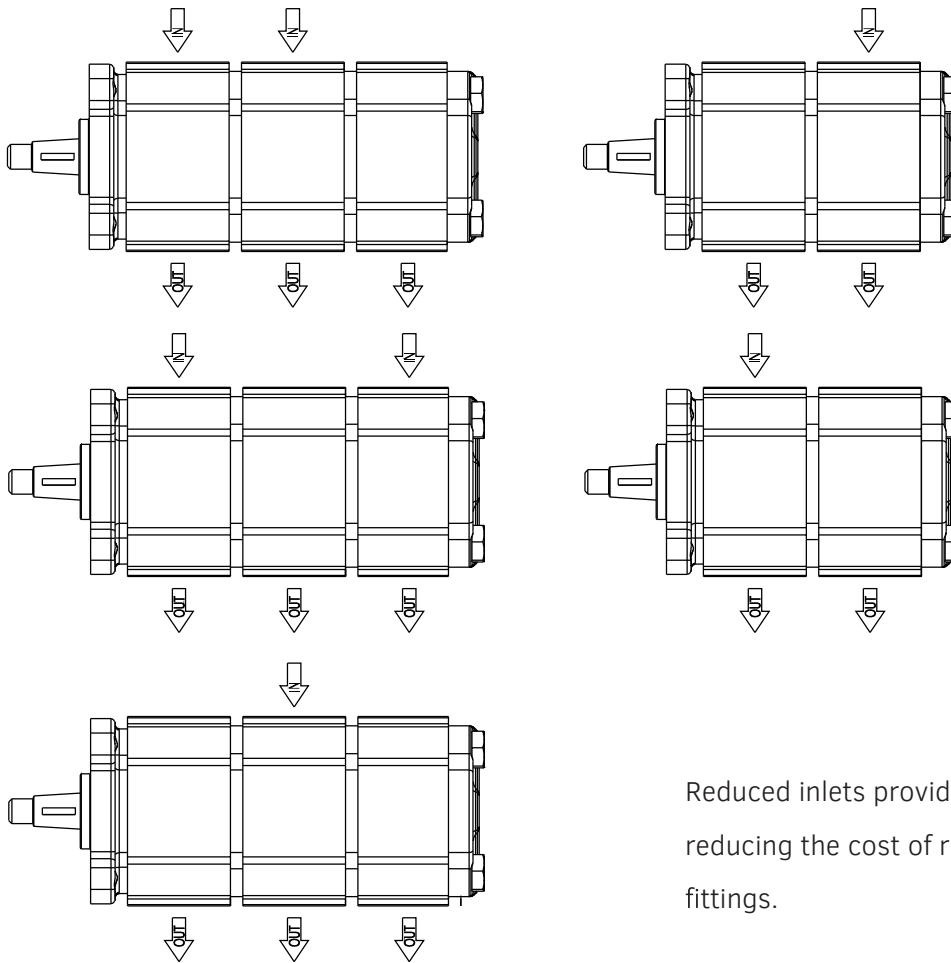

Reduced inlets provide overall systems savings by reducing the cost of redundant inlet hose and fittings.

For the correct choice or other combinations please contact Hydreco Technical Support.

NOTE: multiple pumps with common inlet will be provided with a special body

ORDERING CODE IDENTIFICATION FOR INTERMEDIATE PUMPS

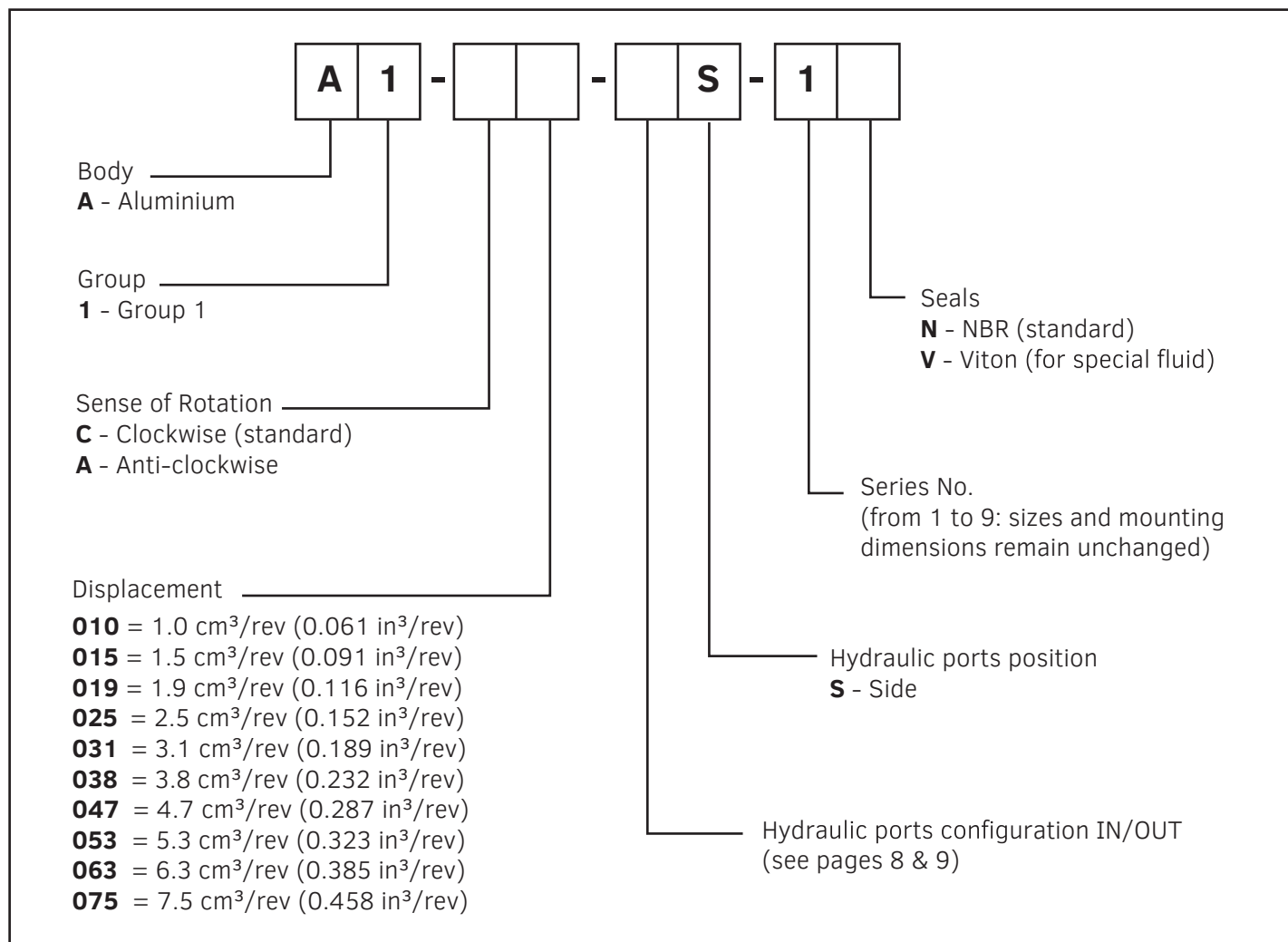

Example

A1-C015-FG2/2S-1N

GR1 intermediate pump - clockwise rotation - (splined shaft - fixed choice) - German flanged ports

DIMENSIONS (side view)

GROUP	SIZE	H mm (inch)	WEIGHT kg
HY1	010	35.7 (1.405)	1.10
	015	37.5 (1.476)	1.10
	019	39.0 (1.535)	1.15
	025	41.3 (1.626)	1.15
	031	43.5 (1.712)	1.15
	038	46.1 (1.814)	1.20
	047	49.5 (1.949)	1.25
	053	51.7 (2.035)	1.30
	063	55.5 (2.180)	1.35
	075	59.2 (2.330)	1.40

The HY1 intermediate pumps include the intermediate flange and coupling to easily assemble tandem or multiple pumps.

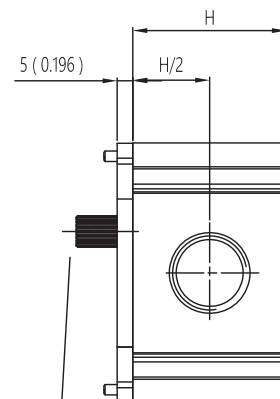

Max Torque = 30 Nm (266 lbf in)

HOW TO MAKE TANDEM PUMPS USING AN INTERMEDIATE PUMP (side view)

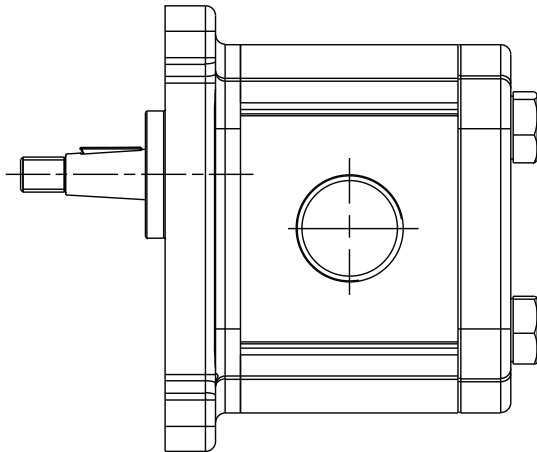

STANDARD PUMP

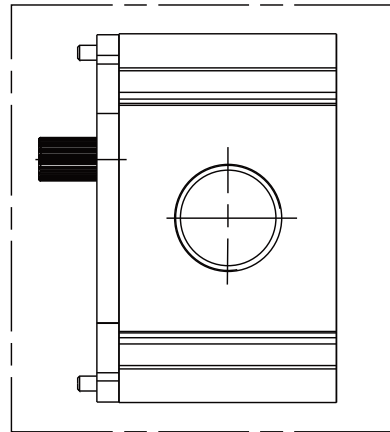

INTERMEDIATE PUMP

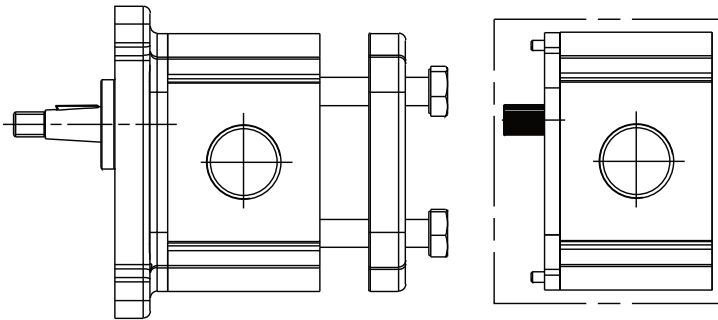

A. Loosen and remove the clamp screws, and remove the cover.

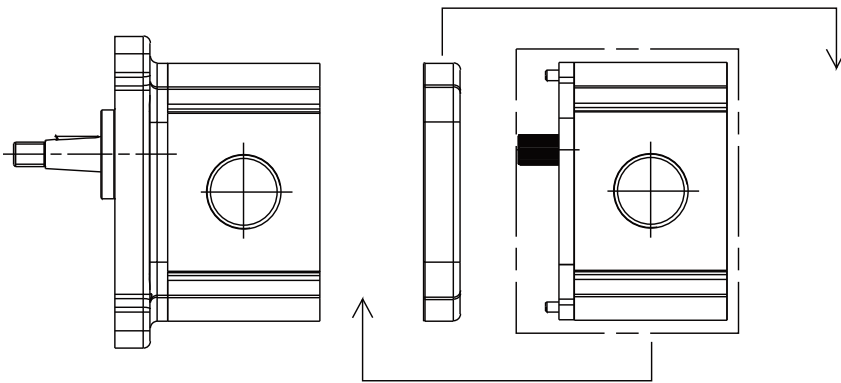

B. Connect the intermediate pump

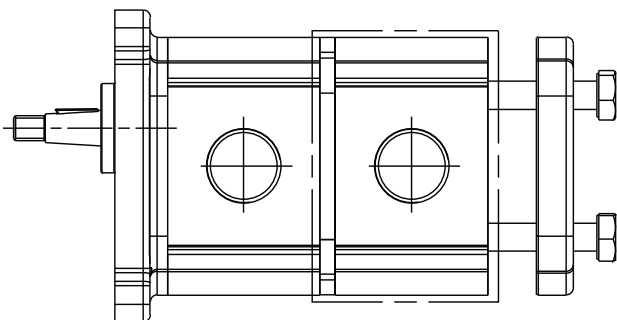

C. Assembling the tandem pump.
Refit the clamp screws.
SCREWS TIGHTENING TORQUE = 29 ± 1 Nm
For length of closure screws = see page 11

UNITS ROTATING CHANGING INSTRUCTIONS

- A. Clean the pump externally with care
- B. Coat the sharp edges of the drive shaft (2) with adhesive tape and smear a layer of clean grease on the shaft and extension to avoid damaging the lip of the shaft seal when removing the mounting flange
- C. Lay the pump on the working area in order to have the mounting flange turned upside.
- D. Loosen, and remove, the clamp screws (1).
- E. Remove the mounting flange (3), taking care to keep the flange as straight as possible during removal.
- F. Ensure that while removing the front mounting flange, the drive shaft and other components remain in position.
- G. Ease the drive gear (2) up to facilitate removal of bearings (4), taking care that the precision ground surfaces do not become damaged, and removed the drive gear
- H. Remove the driven gear (2) without overturning. The rear flange has not to be removed.
- I. Re-locate the driven gear in the position previously occupied by the drive gear (2).
- J. Re-locate the drive gear (2) in the position previously occupied by the driven gear (5).
- K. Re-locate the bushing (4) without rotating. Refit the front mounting flange (3) turned by 180°.
- L. Refit the clamp screws (1).
SCREW TIGHTENING TORQUE = $29 \pm 1\text{Nm}$
- M. Check that the pump rotates freely when the drive shaft (2) is turned by hand.
- N. If not a pressure plate seal may be pinched.
- O. The pump is ready for installation with the new direction of rotation.

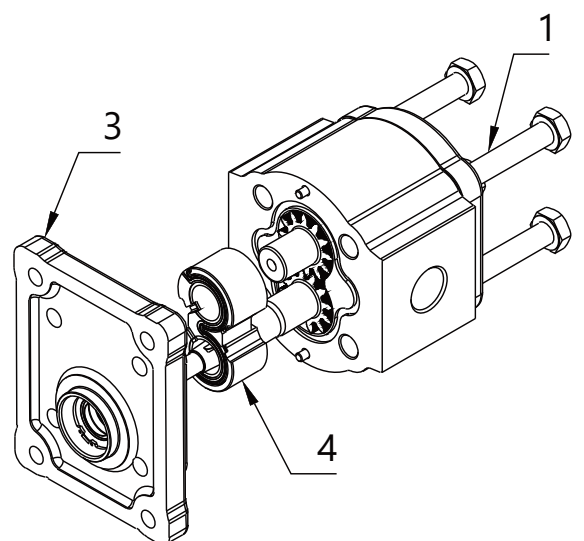
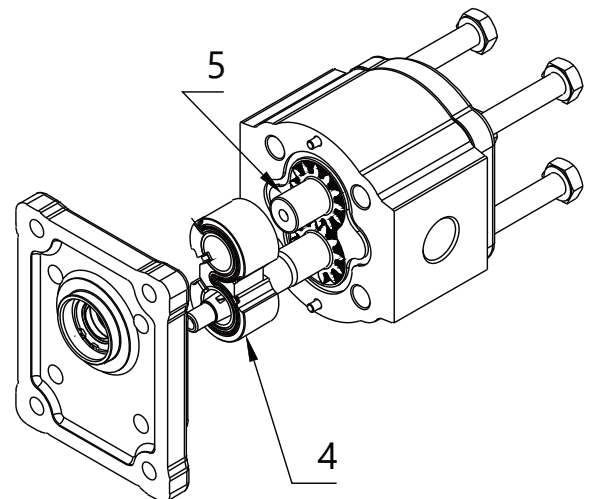
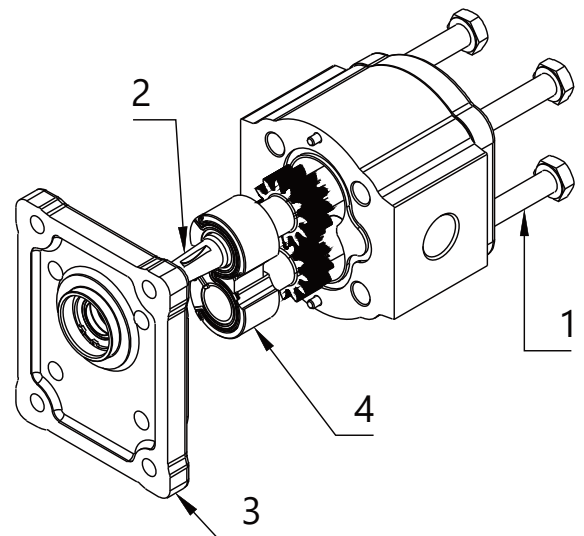

Supported by a worldwide network



CONTACT INFORMATION

EMEA

GERMANY	Hydreco Hydraulics GmbH, Helmstedt (NI)	☎ +49 5351 5586 0	✉ info@hydreco.de
ITALY	Hydreco Hydraulics Italia Srl, Vignola (MO)	☎ +39 059 7700411	✉ sales-it@hydreco.com
ITALY	Hydreco Hydraulics Italia Srl, Parma (PR)	☎ +39 0521 1830520	✉ sales-it@hydreco.com
ITALY	Hydreco Srl, San Cesario S/P (MO)	☎ +39 059 330091	✉ cylinders@hydreco.com
NORWAY	Hydreco Hydraulics Norway AS, Nittedal	☎ +47 22909410	✉ post-no@hydreco.com
UK	Hydreco Hydraulics Ltd, Poole, Dorset	☎ +44 (0) 1202 627500	✉ info-uk@hydreco.com

AMERICAS

NORTH/LATIN	Hydreco Inc/ Continental Hydraulics Inc, Shakopee (MN)	☎ +1 952 895 6400	✉ sales@conthyd.com
--------------------	--	-------------------	---------------------

APAC

AUSTRALIA	Hydreco Hydraulics Pty Ltd, Seven Hills (NSW)	☎ +61 2 9838 6800	✉ sales-au@hydreco.com
AUSTRALIA	Hydreco Hydraulics Pty Ltd, Welshpool (WA)	☎ +61 8 9377 2211	✉ reception-wa@hydreco.com
INDIA	Hydreco Hydraulics India Private Ltd, Bangalore	☎ +91 80 67656300	✉ sales-in@hydreco.com

