

ICE90 - Overcenter valve

Pilot assisted relief with check
90 L/min (23 USgpm) • 270 bar (4000 psi)

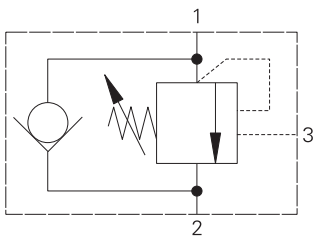

Sectional view

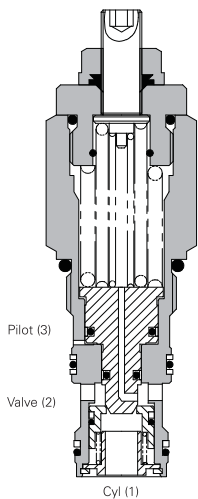

Operation

The check section allows free flow into the actuator then holds and locks the load against movement. The pilot assisted relief valve section will give controlled movement when pilot pressure is applied. The relief section is normally set to open at a pressure at least 1.3 times the maximum load induced pressure but the

pressure required to open the valve and allow movement depends on the pilot ratio of the valve. For optimization of load control and energy usage, a choice of pilot ratios is available.

The pressure required to open the valve and start actuator movement can be calculated as follows:

$$\text{Pilot Pressure} = \frac{(\text{Relief Setting}) - (\text{Load Pressure})}{\text{Pilot Ratio}}$$

Features

Cartridge is economical and fits simple cavity. Allows quick, easy field service - reduces the down time. Interchangeable with pilot check valve of a similar size.

Pilot ratio

4:1 Best suited for applications where load varies and machine structure can induce instability.

8:1 Best suited for applications where the load remains relatively constant.

Performance data

Ratings and specifications

Figures based on: Oil Temp = 40°C Viscosity = 32 cSt (150 SUS)

Rated flow	90 L/min (23 USgpm)
Max relief setting	350 bar (5000 psi).
Max load Induced pressure	270 bar (4000 psi).
Cartridge material	Working parts hardened and ground steel. External surfaces zinc plated.
Standard housing materials	Aluminum (up to 210 bar). Add suffix "377" for steel option.
Mounting position	Unrestricted
Cavity number	A12336 (See Section M)
Torque cartridge into cavity	60 Nm (44 lbs ft)
Weight	1CE90 0.29 kg (0.63 lbs) 1CE95 1.35 kg (2.97 lbs) 1CEE95 2.10 kg (4.62 lbs)
Seal kit number	SK633 (Nitrile) SK633V (Viton®)
Recommended filtration level	BS5540/4 Class 18/13 (25 micron nominal)
Operating temperature	-30° to +90°C (-22° to +194°F)
Leakage	0.3 milliliters/min nominal (5 dpm)
Nominal viscosity range	5 to 500 cSt

Viton is a registered trademark of E.I. DuPont.

Pressure drop

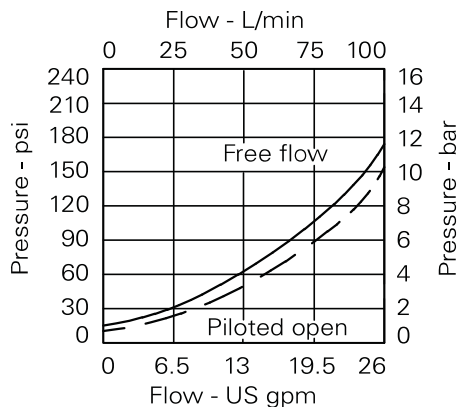

4:1 Version

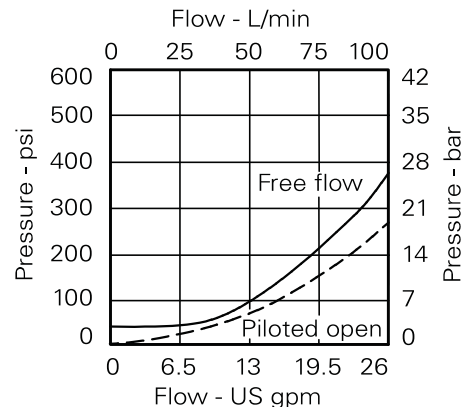

8:1 Version

Where measurements are critical request certified drawings. We reserve the right to change specifications without notice.

ICE90 - Overcenter valve

Pilot assisted relief with check
90 L/min (23 USgpm) • 270 bar (4000 psi)

Model code



1 Function

- 1CE90** - Cartridge Only
- 1CE95** - Cartridge and Body
- 1CEE95** - Cartridges and Dual Body

2 Adjustment means

- F** - Screw Adjustment
 - N** - Fixed - State pressure setting required.
- For fixed versions add setting in 10 bar increments to end of part number. Subject to a ±10% tolerance.

3 Port Sizes

Code	Port size	Housing number - body only			
		Aluminum single	Steel single	Aluminum dual	Steel dual
4W	1/2" BSP Valve & Cyl Port 1/4" BSP Pilot Port	B13625	B13626	C13627	C13628
8T	1/2" SAE Valve & Cyl Port 1/4" SAE Pilot Port	B10806	B10922	C10807	C11561

4 Pressure range @ 4.8 l/min

- Note:** Code based on pressure in bar.
- 20** - 70-225 bar.
Std setting 100 bar
 - 35** - 200-350 bar.
Std setting 210 bar
- Std setting made at 4.8 L/min

5 Seals

- S** - Nitrile (For use with most industrial hydraulic oils)
- SV** - Viton (For high temperature and most special fluid applications)

6 Pilot Ratio

- 4** - 4:1
 - 8** - 8:1
- Other ratios available upon request

Dimensions

mm (inch)

Cartridge only

Basic Code 1CE90

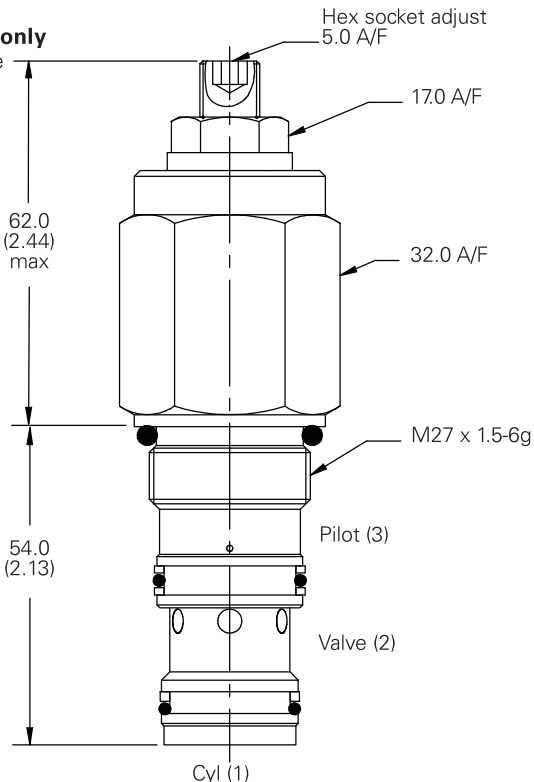

Note: For applications above 210 bar - please consult our technical department or use the steel body option

Note: Tightening torque of "F" adjuster locknut - 20 to 25 Nm

Single valve

1/2" Ports
Basic Code 1CE95

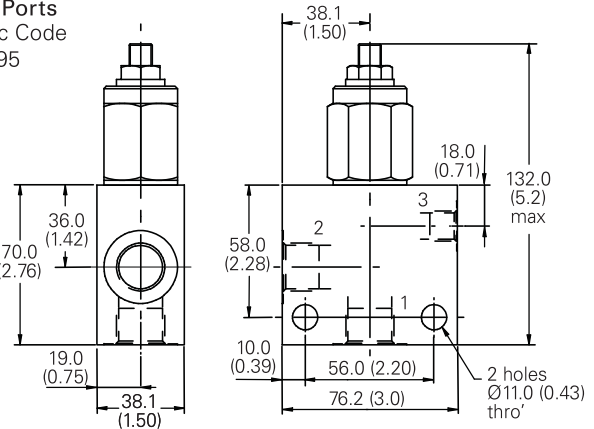

Dual valve

1/2" Ports
Basic Code 1CEE95
Internally Cross Piloted

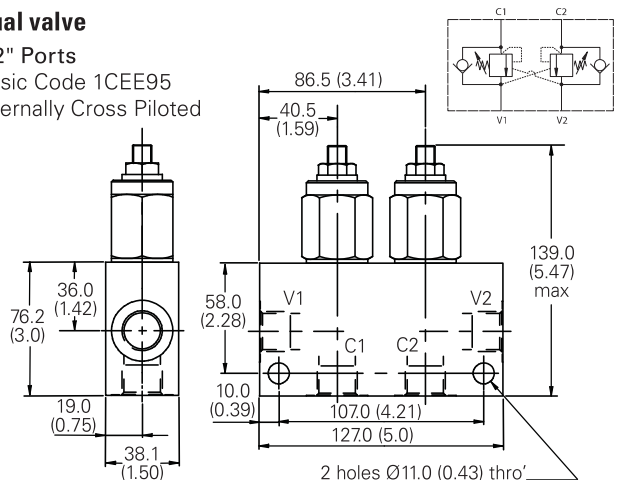

Where measurements are critical request certified drawings. We reserve the right to change specifications without notice.