

MERS

FLOW RESTRICTOR VALVE

SERIES 50

MODULAR VERSION

ISO 4401-03 (CETOP 03)

p max 350 bar
Q max (see table of performances)

MOUNTING INTERFACE

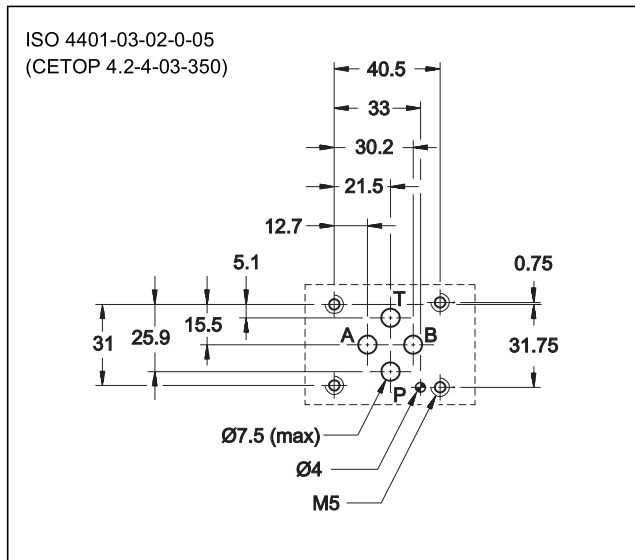

OPERATING PRINCIPLE

- This is a non-compensated flow control valve with a check valve for reverse free flow. It is made in the modular version and with mounting surface according to the ISO 4401 (CETOP RP 121 H) standards; it can be assembled quickly without use of pipes, but using only suitable tie-rods or bolts, thus forming compact modular groups.
- It is also available as a reversible valve (G* versions). Meter-in or meter-out control depending on the way of assembly the valve on the OR subplate.
- All the configurations have an incorporated check valve that allows reverse free flow (cracking pressure of 0,5 bar).
- It is normally supplied with a hexagonal head adjustment screw.

CONFIGURATIONS (see hydraulic symbols table)

- “SA”: control of the flow exiting from the actuator on line A .
- “SB”: control of the flow exiting from the actuator on line B.
- “D”: Allows an independent flow control exiting from the two chambers of the actuator. (Standard)
- “RD”: Allows an independent flow control entering in the two chambers of the actuator.
- “G*”: Reversible valve. See at par. 1

PERFORMANCES (measured with mineral oil of viscosity 36 cSt at 50°C)

Maximum operating pressure	bar	350
Check valve cracking pressure		0,5
Maximum flow rate in the controlled lines	l/min	50
Maximum flow rate in the free lines		75
Min. controlled flowrate with Δp 10 bar		≤0,060
Ambient temperature range	°C	-20 / +50
Fluid temperature range	°C	-20 / +80
Fluid viscosity range	cSt	10 ÷ 400
Fluid contamination degree	According to ISO 4406:1999 class 20/18/15	
Recommended viscosity	cSt	25
Mass	kg	1,3

HYDRAULIC SYMBOLS

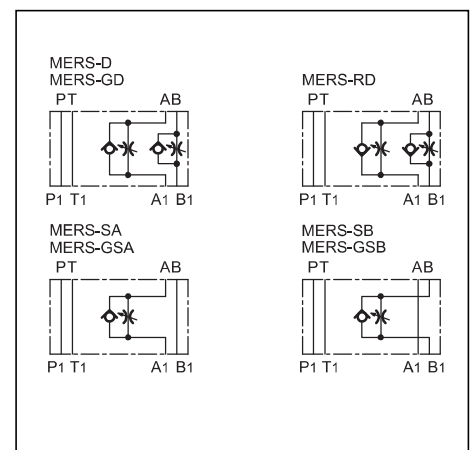

1 - IDENTIFICATION CODE

	M	E	R	S	-		/		/	50	/	
--	----------	----------	----------	----------	----------	--	----------	--	----------	-----------	----------	--

ISO 4401-03 (CETOP 03) size Modular version

Flow restrictor valve with check valve for reverse free flow

Configurations:

- D:** meter out control on lines A and B (**standard**)
- RD:** meter in control on lines A and B
- SA:** meter out control on line A
- SB:** meter out control on line B

Configurations G* - reversible valve (**NOTE**)

- GD:** control on lines A and B
- GSA:** control on lines A
- GSB:** control on lines A

Seals: omit for mineral oils
V = viton for special fluids

Series No. (the overall and mounting dimensions remain unchanged from 50 to 59)

M = Adjustment with SICBLOC knob (omit for adjustment with hexagonal head adjustment screw)

NOTE: the valve body does not provide the OR seats. The mounting interface is achieved by interposition of an OR subplate. The control of flow (meter-in or meter-out) is depending on the way of assembly the valve on the subplate.

2 - CHARACTERISTIC CURVES (values obtained with viscosity of 36 cSt at 50°C)

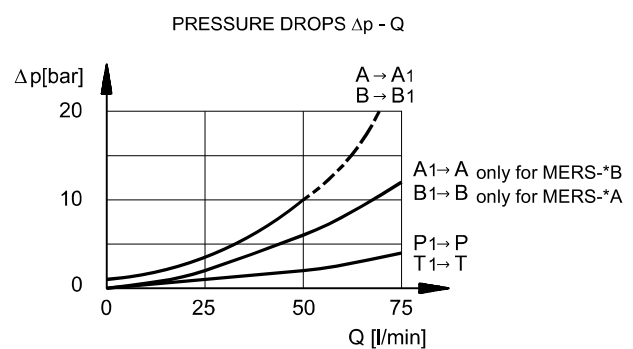
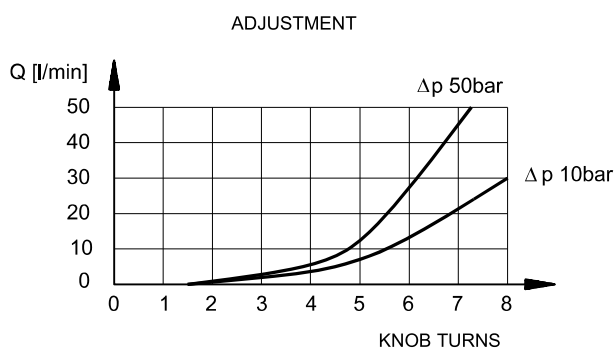

3 - HYDRAULIC FLUIDS

Use mineral oil-based hydraulic fluids HL or HM type, according to ISO 6743-4. For these fluids, use NBR seals. For fluids HFDR type (phosphate esters) use FPM seals (code V). For the use of other kinds of fluid such as HFA, HFB, HFC, please consult our technical department. Using fluids at temperatures higher than 80 °C causes a faster degradation of the fluid and of the seals characteristics.

The fluid must be preserved in its physical and chemical characteristics.

4 - OVERALL AND MOUNTING DIMENSIONS MERS -D, -RD and -S*

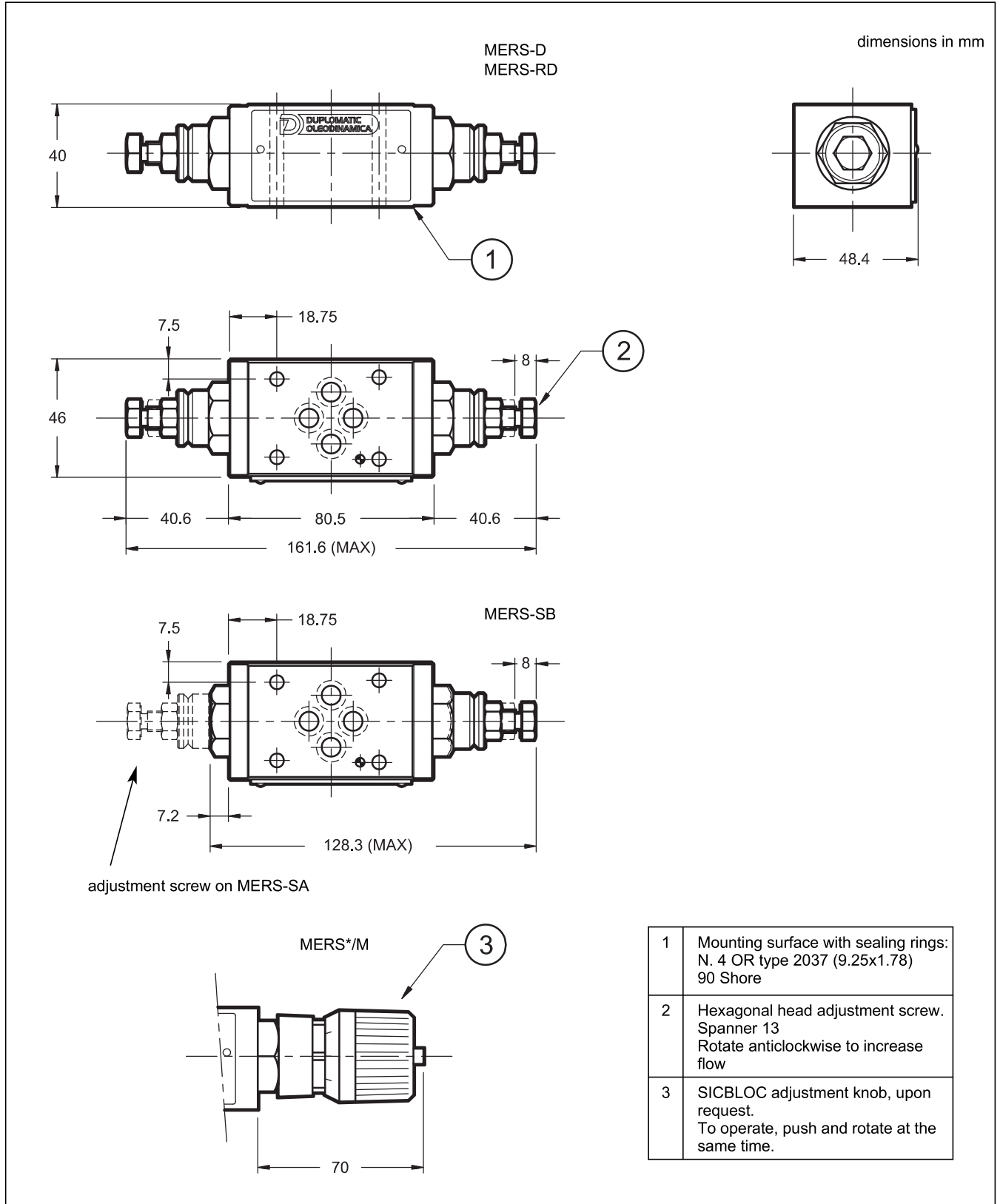

4 - OVERALL AND MOUNTING DIMENSIONS MERS-G*

