

SV15-8-O/OP/OS - Solenoid valve

Poppet type, normally open solenoid valve
37 L/min (10 USgpm) • 350 bar (5000 psi)

A

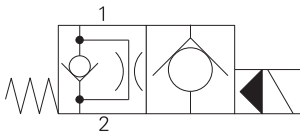

Operation

In the de-energized position the valve allows free flow from port 2 to 1 and a restricted flow through the pilot orifice from port 1 to 2.

When the solenoid is energized the pilot poppet closes the orifice and the valve closes blocking flow from port 2 to 1 while allowing free flow from port 1 to 2.

Features

Hardened and ground working parts. Lapped seat for low leakage. IP69K Tough coil compatibility. Continuously rated. Compact design with low pressure drop. 350 bar working pressure.

Sectional view

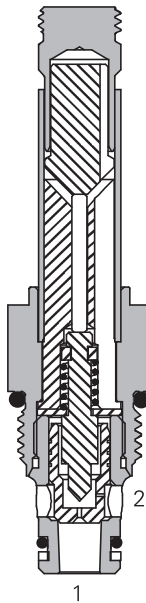

Performance data

Ratings and specifications

Performance data is typical with fluid at 21,8 cSt (105 SUS) and 49°C (120°F)

Typical application pressure (all ports)	350 bar (5000 psi)
Cartridge fatigue pressure (infinite life)	310 bar (4500 psi)
Rated flow	37 L/min (10 USgpm)
Internal leakage	5 drops/min, max @ 210 bar (3000 psi)
Temperature range	-40° to 100°C (-40° to 212°F)
Coil duty	Continuous from 85% to 110% of nominal voltage
Cavity	C-8-2
Fluids	All general purpose hydraulic fluids such as: MIL-H-5606, SAE 10, SAE 20 etc
Filtration	Cleanliness code 18/16/13
Housing material (standard)	Steel
Weight cartridge only	0,11 kg (0.25 lbs)
Seal kit	02-165875 (Buna-N), 02-165877 (Viton®)

Viton is a registered trademark of E.I. DuPont

Description

This is a 2-way, 2-position, poppet type, high pressure, pilot operated, normally open solenoid valve. This valve is used in applications requiring low leakage, such as load holding applications or as a general purpose diverter or dump valve.

Pressure drop

Cartridge only

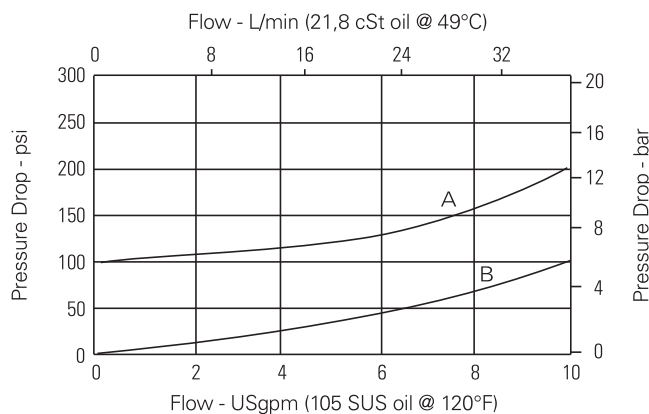

- A** - Port 1 to port 2 energized
- B** - Port 2 to port 1 de-energized

Where measurements are critical request certified drawings. We reserve the right to change specifications without notice.

SV15-8-O/OP/OS - Solenoid valve

Poppet type, normally open solenoid valve
37 L/min (10 USgpm) • 350 bar (5000 psi)

Model code

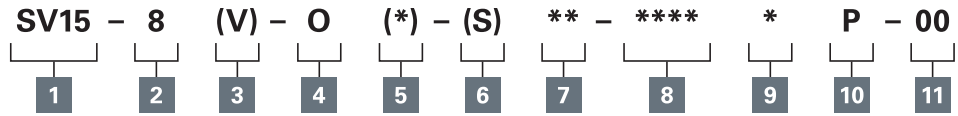

A

1 Function
SV15 - Solenoid valve

2 Size
8 - 8 size

3 Seal material
Blank - Buna-N
V - Viton®

4 Style
O - Normally open

5 Manual override option
Blank - No manual override
P - Push type
S - Screw type

For valve dimensions with manual override option installed see page A-980.

6 Valve housing material
Blank - Cartridge only
S - Steel

Dimensions
mm (inch)
Cartridge only

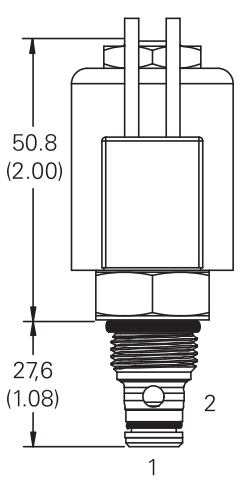

7 Port size

Code	Port size	Housing number
0	Cartridge only	
2G	1/4" BSPP	02-160733
3G	3/8" BSPP	02-160734
4T	SAE 4	02-160736
6T	SAE 6	02-160737
8T	SAE 8	02-160738

See section J for housing details.

8 Voltage rating

00 - No coil	24A - 24VAC
12D - 12VDC	115A - 115VAC
24D - 24VDC	230A - 230VAC
36D - 36VDC	12B - 12VDC/w diode*
	24B - 24VDC/w diode*

*Optional arc suppression diode.

9 Connector types
Blank - No coil
G - ISO 4400 DIN 43650
Q - Spade terminals
W - Flying lead
N - Deutsch (DC only)
Y - Amp JR (DC only)
D - Metripack 150 male (DC only)
J - Metripack 280 male (DC only)

10 Coil series
P - 8 series, 23 W

For coil part numbers and dimensions see section C.

11 Special features
00 - None

(Only required if valve has special features, omitted if "00".)

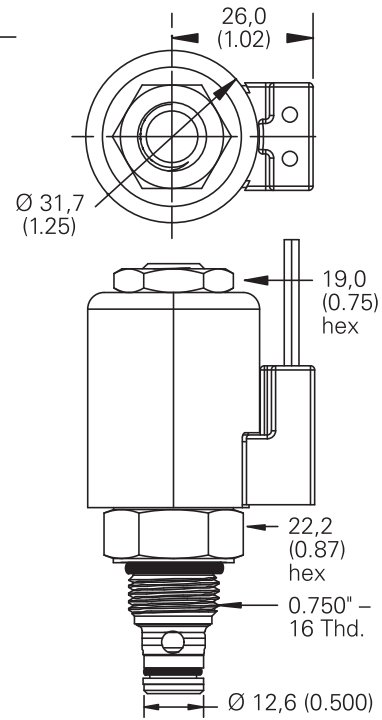

Torque cartridge in steel housing 34-41 Nm (25-30 ft lbs)

Note: When solenoid valve is ordered as cartridge only, coil nut is included.

Installation drawing

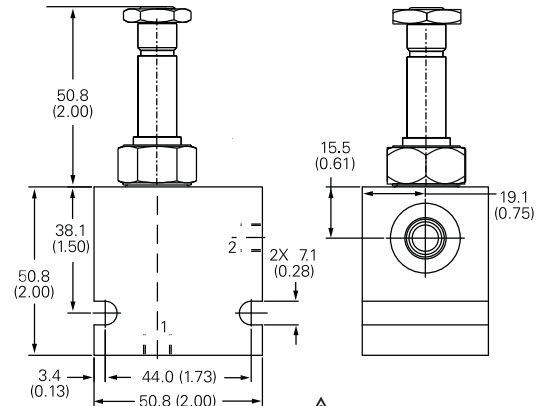

Warning
Maintain 5-8 Nm (4-6 ft lbs) maximum torque on valve tube nut.
Over tightening may cause valve failure.

Where measurements are critical request certified drawings. We reserve the right to change specifications without notice.