

IN-LINE FLOW REGULATOR SERIES RFL

The in-line flow regulator regulates the speed of the piston rod in the pneumatic cylinders.

Two versions are available:

- type U (unidirectional) regulates the flow only in one of the two directions of air flow.
- type B (bidirectional) regulates the flow in both directions of air flow.

Regulation: manual or with a screwdriver.

Max. temperature 70°C (158°F)

Max. pressure: 10 bar (1MPa-145 psi)



COMPONENTS

- ① Aluminium block
- ② Brass adjusting knob
- ③ Brass knob locking ring nut
- ④ Brass wall locking ring nut
- ⑤ Brass nipple
- ⑥ Brass regulation needle
- ⑦ Technopolymer gasket insert
- ⑧ NBR gasket
- ⑨ Part of needle
- ⑩ Flow window

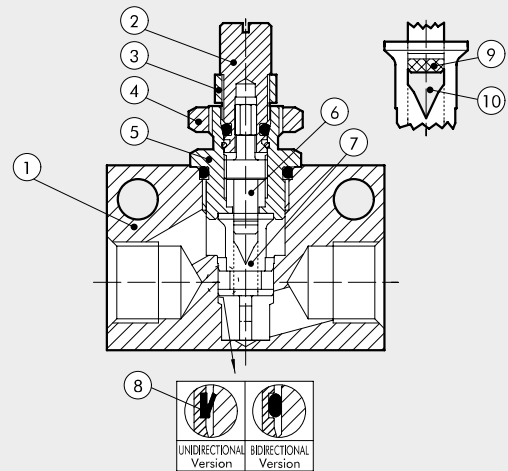

DIMENSIONS

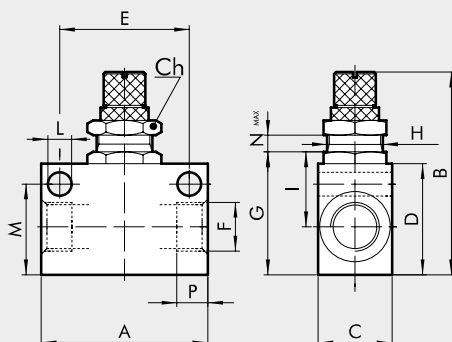

DIMENSIONS	THREAD F	M5	1/8	1/4	3/8	1/2
P		4.2	7	8	10	11
E		15	25	35	35	44
H		M10x0.75	M12x1	M12x1	M15x1	M15x1
N _{max}		3.3	5.5	5	7.5	7.5
A		21	31	45	50	59
B		37	48	53.5	59	67
C		14	16	20	25	30
G		18	25	33	34	43.5
I		11.6	15	22	22	24
D		16	22	30	30	40
M		12.5	18.2	24.5	25.5	35
Ch		12	16	16	20	20
L		4.2	4.2	6.5	6.5	6.5

FLOW CHARTS Pm = 6 bar
RFL M5

Flow rate [NI/min]

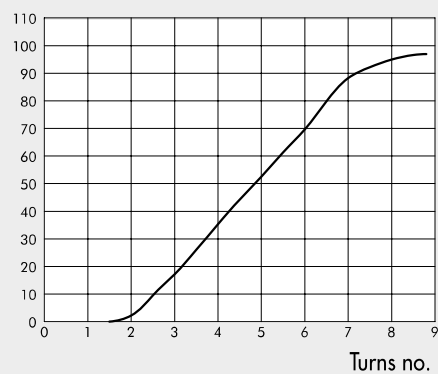
RFL 1/8

Flow rate [NI/min]

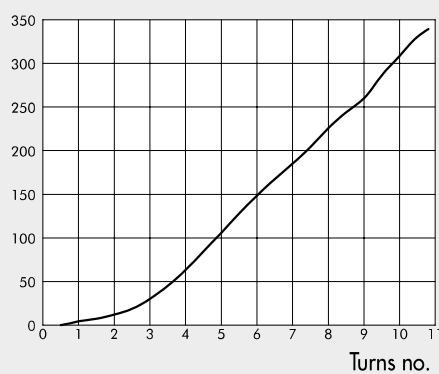
RFL 1/4

Flow rate [NI/min]

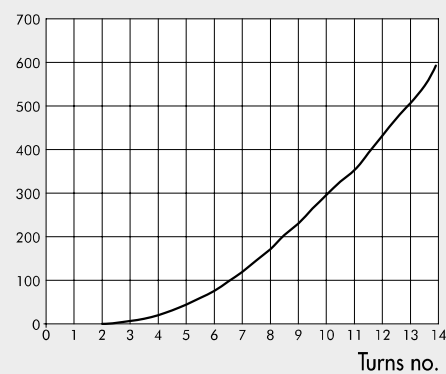
RFL 3/8

Flow rate [NI/min]

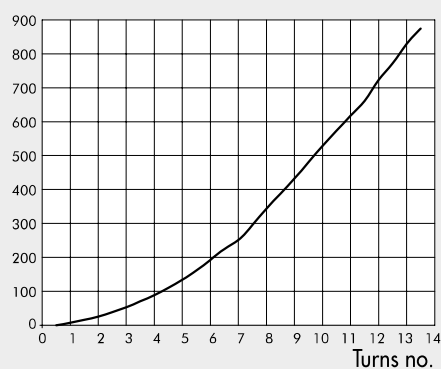
RFL 1/2

Flow rate [NI/min]

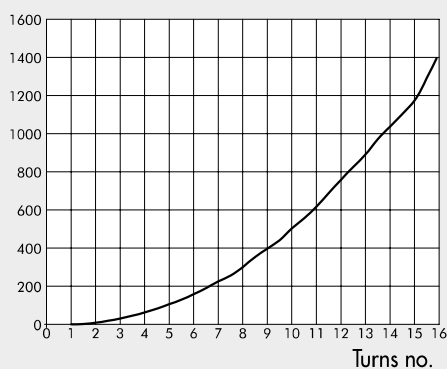
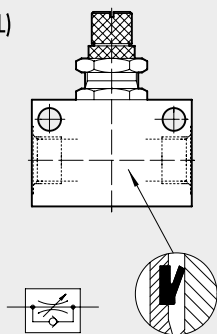
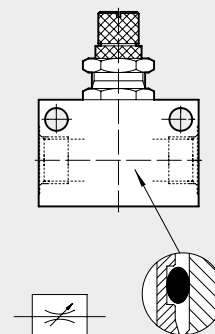
ORDERING CODES
RFL U (UNIDIRECTIONAL)

RFL B (BIDIRECTIONAL)

Code
Ref.

9041001	RFL U M5
9041002	RFL U 1/8
9041003	RFL U 1/4
9041004	RFL U 3/8
9041005	RFL U 1/2

Code
Ref.

9041201	RFL B M5
9041202	RFL B 1/8
9041203	RFL B 1/4
9041204	RFL B 3/8
9041205	RFL B 1/2