

APM SERIES

INTERCHANGE > ISO 16028 - NFPA T3.20.15 - HTMA (size 3/8")



Easy
CUP



TECHNICAL FEATURES AND OPTIONS

	Interchange ISO 16028 NFPA T3.20.15 HTMA (size 3/8")		Sealing description Nitrile NBR		Connection system Push
	Available sizes From 3/8" to 1-1/2"		Material/treatment Carbon steel /Cr3		Available threads BSP - NPT - SAE
	Operating pressure Up to 350 bar		Locking mechanism Locking ball+ Safety Lock (on female coupling)		Flow rate Up to 750 l/min
	Temperature (°C) -20°C / +100°C		Valving style Flat Face		Connection under pressure Connection: Male side only (see Benefits). Disconnection: Not allowed.

BENEFITS

- Easy connection with male side under residual pressure (female side to drain) thanks to the internal valve.
- Flat face is easy to clean, reducing the inclusion of contamination inside the hydraulic circuit.
- Minimal fluid spillage during disconnection, reducing fluid spillage to the environment.
- Minimal air inclusion during connection.
- Internal valve design creates minimal pressure drop, maintaining circuit efficiency in the system.
- Male body black zinc plated for identification
- The modular design allows flexibility with a wide range of configurations.
- Good resistance to pressure impulses.
- Compact slim design.
- Safe and simple to use.

HOW TO USE

- Before to connect, clean the mating surface of the couplings to avoid dirt inclusion in the circuit.
- To connect push the male half towards the female half or vice versa.
- After connection turn the external sleeve to engage safety lock function, to prevent accidental disconnection.
- To disconnect turn the external sleeve until the sleeve lock notch match the safety lock ball and push back the sleeve.

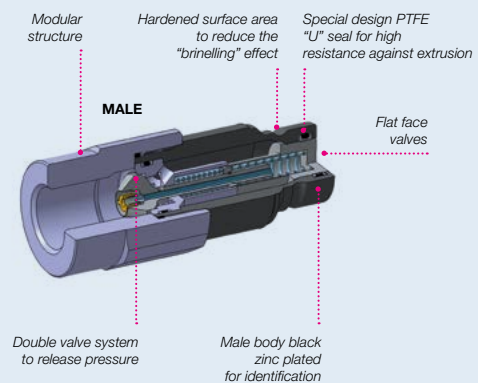
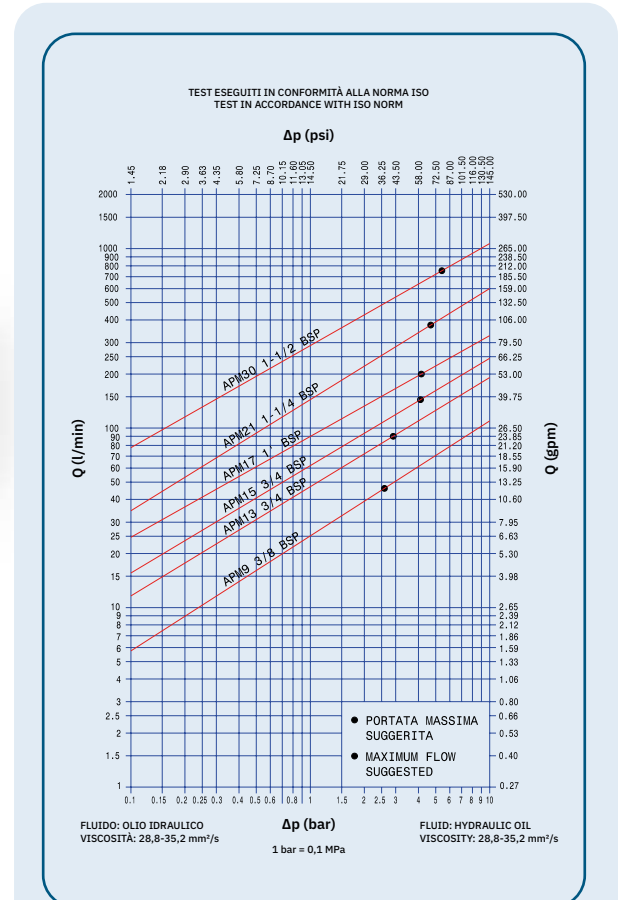

MAIN APPLICATIONS

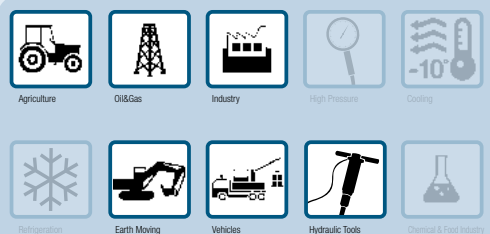

FLAT FACE

FLAT FACE SCREW

CASTING

POPPET SCREW

POPPET

HIGH PRESSURE

CHECK VALVE

BOP PRODUCTS

MULTICOUPLINGS

PERFORMANCES

Size		Series/Size	Max. flow suggested		Connect force		Disconnect force		Spillage*
in	mm (ISO)		l/min	gpm	N	lbf	N	lbf	ml
3/8	10,0	APM9	46	12,19	165	37,13	40	9,00	0,02
1/2	12,5	APM13	90	23,85	190	42,75	70	15,75	0,01
5/8	16,0	APM15	148	39,22	160	36,00	50	11,25	0,03
3/4	19,0	APM17	200	53,00	260	58,50	80	18,00	0,18
1	25,0	APM21	378	100,17	300	67,50	90	20,25	0,18
1 1/2	38,0	APM30	750	198,75	440	99,00	80	18,00	0,40

Size	Series/Size	Max. operating pressure				Burst pressure			
		Coupled		Male		Coupled		Male	
		MPa	psi	MPa	psi	MPa	psi	MPa	psi
3/8	APM9	35	5075	35	5075	100	14500	120	17400
1/2	APM13	33	4785	33	4785	100	14500	120	17400
5/8	APM15	33	4785	33	4785	100	14500	120	17400
3/4	APM17	33	4785	33	4785	100	14500	120	17400
1	APM21	30	4350	30	4350	80	11600	100	14500
1 1/2	APM30	27	3915	27	3915	80	11600	100	14500

* Spillage is an indicative value of the fluid loss during disconnection (according to ISO norm test method).

Theoretical calculation of connect force with residual pressure:

$$F_p (N) = F_i + (P_m \times 5)$$

F_i = Connection force without residual pressure (N)

P_m = Residual pressure in the male coupling (MPa)

EXAMPLE

To connect the male coupling APM13 with 20 Mpa of residual pressure, it is necessary the following force:

$$F_p = F_i + (P_m \times 5) = 190 + (20 \times 5) = 290 \text{ N}$$

Different possible configurations:

Different threads available upon request.

Temperature range:

Seals in NBR (Nitrile): from -20 °C to +100 °C (from -4 °F to +212 °F)

Please read carefully Instructions and warnings for proper selection of the products.

Tests performed:

Tested with female couplings "A" series.

Qualification tests have been performed with hydraulic oil using couplings with NBR (Nitrile) seals.

The max. operating pressure have been verified for 100.000 impulses according to ISO norm test method.

! WARNING

A defect, a wrong choice or an improper use of products, can cause injury to persons, animals and objects.

Connect under pressure products are suitable to be connected under residual (static) pressure.

Never connect or disconnect with dynamic pressure (e.g. pump on).

Connection with residual pressure (pressure trapped in the circuit) allowed with female to drain.

Do not use the male coupling disconnected with high impulse pressure.

Do not couple-uncouple with flow in the circuit.

Do not couple-uncouple when the temperature inside of the circuit is higher than 80 °C (176 °F).

Check the maximum allowable working pressure of the port in use.

It is important to limit contamination in the circuit to avoid compromising the function of the internal valves.

Make sure that the medium used is compatible with seal and material as indicated for each series.

In case of doubt please contact Stucchi Technical Support.

The interchangeability is mentioned under the assumption that the manufacturer of the considered products has not changed any dimension.

It is mandatory to carefully read and closely follow the instructions before selecting or using any Stucchi products.

Always refer to the version uploaded in the Instructions and warning section of stucchigroup.com website for the latest release.

For specific, product-related, instructions, please contact Stucchi technical service.

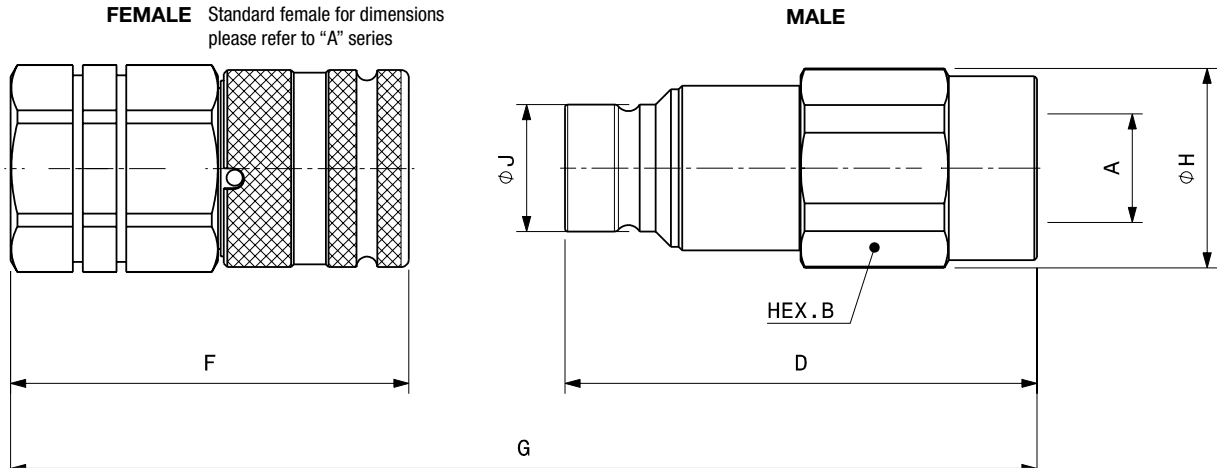

Port description: FEMALE THREAD BSPP (ISO 1179-1)

BODY SIZE	Descriptive Code	Item Code	ISO DN	PORT (A)	Overall Length		Length		Hex		Diameter		Diameter		Weight						
					mm	in	mm	in	mm	in	mm	in	mm	in	kg	lb					
3/8"	M APM9 3/8 BSP	Male 805200001	10,0	3/8"	G	(F+D)-16	(F+D)-0.630	D	80,0	3,15	B	27,0	1,06	H	29,0	1,14	J	19,7	0,78	0,20	0,43
3/8"	M APM9 1/2 BSP	Male 805200003	10,0	1/2"	G	(F+D)-16	(F+D)-0.630	D	82,5	3,25	B	27,0	1,06	H	29,0	1,14	J	19,7	0,78	0,20	0,43
1/2"	M APM13 1/2 BSP	Male 805200005	12,5	1/2"	G	(F+D)-17,3	(F+D)-0.681	D	91,0	3,58	B	36,0	1,42	H	38,5	1,52	J	24,5	0,96	0,41	0,90
1/2"	M APM13 3/4 BSP	Male 805200007	12,5	3/4"	G	(F+D)-17,3	(F+D)-0.681	D	93,5	3,68	B	36,0	1,42	H	38,5	1,52	J	24,5	0,96	0,40	0,89
5/8"	M APM15 3/4 BSP	Male 805200009	16,0	3/4"	G	(F+D)-17,6	(F+D)-0.693	D	95,0	3,74	B	36,0	1,42	H	38,5	1,52	J	27,0	1,06	0,43	0,94
3/4"	M APM17 1 BSP	Male 805200011	19,0	1"	G	(F+D)-22	(F+D)-0.866	D	108,5	4,27	B	46,0	1,81	H	49,8	1,96	J	30,0	1,18	0,75	1,65
1"	M APM21 1-1/4 BSP	Male 805200017	25,0	1 1/4"	G	(F+D)-23	(F+D)-0.906	D	123,5	4,86	B	55,0	2,17	H	59,8	2,35	J	36,0	1,42	1,16	2,56
1-1/2"	M APM30 1-1/2 BSP	Male 805200015	38,0	1 1/2"	G	(F+D)-28,6	(F+D)-1,126	D	146,9	5,78	B	70,0	2,76	H	75,8	2,98	J	57,0	2,24	2,58	5,69

Port description: FEMALE THREAD NPT (ANSI B.1.20.1)

BODY SIZE	Descriptive Code	Item Code	ISO DN	PORT (A)	Overall Length		Length		Hex		Diameter		Diameter		Weight						
					mm	in	mm	in	mm	in	mm	in	mm	in	kg	lb					
3/8"	M APM9 3/8 NPT	Male 805201001	10,0	3/8"	G	(F+D)-16	(F+D)-0.630	D	80,0	3,15	B	27,0	1,06	H	29,0	1,14	J	19,7	0,78	0,21	0,46
3/8"	M APM9 1/2 NPT	Male 805201003	10,0	1/2"	G	(F+D)-16	(F+D)-0.630	D	82,5	3,25	B	27,0	1,06	H	29,0	1,14	J	19,7	0,78	0,21	0,45
1/2"	M APM13 1/2 NPT	Male 805201005	12,5	1/2"	G	(F+D)-17,3	(F+D)-0.681	D	91,0	3,58	B	36,0	1,42	H	38,5	1,14	J	24,5	0,96	0,43	0,95
1/2"	M APM13 3/4 NPT	Male 805201007	12,5	3/4"	G	(F+D)-17,3	(F+D)-0.681	D	93,5	3,68	B	36,0	1,42	H	38,5	1,52	J	24,5	0,96	0,42	0,91
5/8"	M APM15 3/4 NPT	Male 805201009	16,0	3/4"	G	(F+D)-17,6	(F+D)-0.693	D	95,0	3,74	B	36,0	1,42	H	38,5	1,52	J	27,0	1,06	0,44	0,96
3/4"	M APM17 1 NPT	Male 805201011	19,0	1"	G	(F+D)-22	(F+D)-0.866	D	108,5	4,27	B	46,0	1,81	H	49,8	1,96	J	30,0	1,18	0,76	1,68
1"	M APM21 1-1/4 NPT	Male 805201017	25,0	1 1/4"	G	(F+D)-23	(F+D)-0.906	D	123,5	4,86	B	55,0	2,17	H	59,8	2,35	J	36,0	1,42	1,20	2,65
1-1/2"	M APM30 1-1/2 NPT	Male 805201015	38,0	1 1/2"	G	(F+D)-28,6	(F+D)-1,126	D	146,9	5,78	B	70,0	2,76	H	75,8	2,98	J	57,0	2,24	2,60	5,72

Port description: FEMALE THREAD SAE (ISO 11926-1 & SAE J1926-1)

BODY SIZE	Descriptive Code	Item Code	ISO DN	PORT (A)	Overall Length		Length		Hex		Diameter		Diameter		Weight						
					mm	in	mm	in	mm	in	mm	in	mm	in	kg	lb					
3/8"	M APM9 1/2 SAE	Male 805204001	10,0	3/4-16UNF	G	(F+D)-16	(F+D)-0.630	D	82,5	3,25	B	27,0	1,06	H	29,0	1,14	J	19,7	0,78	0,21	0,45
1/2"	M APM13 5/8 SAE	Male 805204003	12,5	7/8-14UNF	G	(F+D)-17,3	(F+D)-0.681	D	91,0	3,58	B	36,0	1,42	H	38,5	1,14	J	24,5	0,96	0,41	0,91
1/2"	M APM13 3/4 SAE	Male 805204005	12,5	1-1/16-12UN	G	(F+D)-17,3	(F+D)-0.681	D	93,5	3,68	B	36,0	1,42	H	38,5	1,52	J	24,5	0,96	0,40	0,88
5/8"	M APM15 3/4 SAE	Male 805204007	16,0	1-1/16-12UN	G	(F+D)-17,6	(F+D)-0.693	D	95,0	3,74	B	36,0	1,42	H	38,5	1,52	J	27,0	1,06	0,43	0,94
3/4"	M APM17 1 SAE	Male 805204009	19,0	1-5/16-12UN	G	(F+D)-22	(F+D)-0.866	D	108,5	4,27	B	46,0	1,81	H	49,8	1,96	J	30,0	1,18	0,76	1,66
1"	M APM21 1-1/4 SAE	Male 805204017	25,0	1-5/8-12UN	G	(F+D)-23	(F+D)-0.906	D	123,5	4,86	B	55,0	2,17	H	59,8	2,35	J	36,0	1,42	1,19	2,61
1-1/2"	M APM30 1-1/2 SAE	Male 805204015	38,0	1-7/8-12UN	G	(F+D)-28,6	(F+D)-1,126	D	146,9	5,78	B	70,0	2,76	H	75,8	2,98	J	57,0	2,24	2,56	5,64

To calculate G see measure F in the leaflet A series



SPARE KIT SEAL FOR MALE

Repair kit / OR+BK		
Body Size	Description	Part Number
3/8"	M APM9	815700337
1/2"	M APM13	815700339
5/8"	M APM15	815700341
3/4"	M APM17	815700655
1"	M APM21	815700345
1 1/2"	M APM30	815700697*

* OR + O-Ring holder

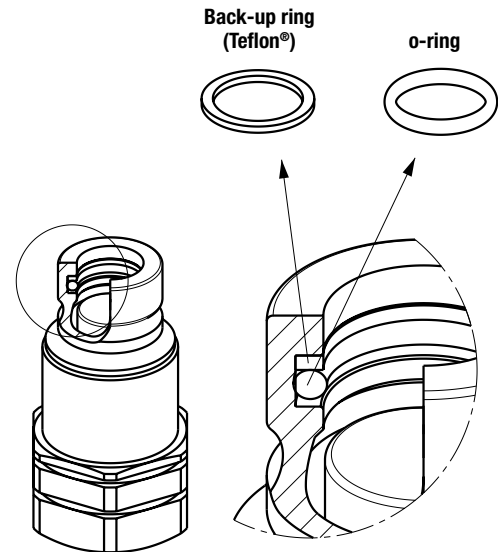

O-Ring in NBR
BackUp in PTFE

PROTECTIVE CAPS FOR APM SERIES

Protective caps are always recommended to protect the couplings from damage, dirt inclusion, and will increase the product life. This is particularly important in mobile applications where exposure to weather and aggregate materials are common.

The protection caps for APM couplings are manufactured in plastic with connection lanyard (standard color red, other colors available upon request).

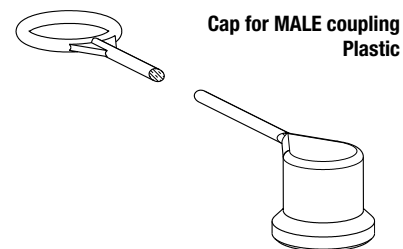

Cap for MALE coupling
Plastic

Protective Cap				
Body Size	Port size	Description	Part number	Material/Color
3/8"	3/8"	M APM9	815100025	Plastic/Red
3/8"	1/2"	M APM9	815100027	Plastic/Red
1/2"	1/2"	M APM13	815100029	Plastic/Red
1/2"	3/4"	M APM13	815100031	Plastic/Red
5/8"	3/4"	M APM15	815100011	Plastic/Red
3/4"	1"	M APM17	815100013	Plastic/Red
1"	1-1/4"	M APM21	815100015	Plastic/Red
1-1/2"	1-1/4"	M APM30	815100017	Plastic/Red