

1CER30 - Overcenter valve

Part balanced, pilot assisted relief with check
30 L/min (8 USgpm) • 270 bar (4000 psi)

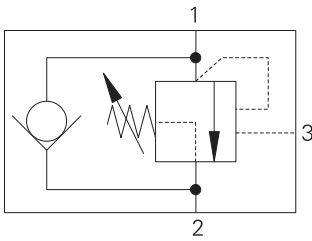

Operation

The check section allows free flow into the actuator then holds and locks the load against movement. The pilot assisted relief valve section will give controlled movement when pilot pressure is applied. The relief section is normally set to open at a pressure at least 1.3 times the maximum load induced pressure but the pressure required to open the

valve and allow movement depends on the pilot ratio of the valve. For optimization of load control and energy usage, a choice of pilot ratios is available.

The pressure required to open the valve and start actuator movement can be calculated as follows:

$$\text{Pilot Pressure} = \frac{(\text{Relief Setting}) - (\text{Load Pressure})}{\text{Pilot Ratio}}$$

Features

Cartridge is economical and fits simple cavity. Allows quick, easy field service - reduces down time. Interchangeable with pilot check valve of a similar size.

Pilot ratio

2.5:1 Best suited for extremely unstable applications such as long booms or flexible frameworks.

4:1 Best suited for applications where load varies and machine structure can induce instability.

Sectional view

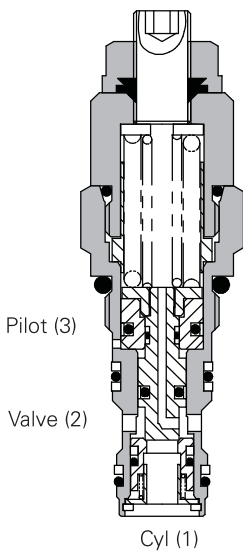

Performance data

Ratings and specifications

Figures based on: Oil Temp = 40° C Viscosity = 32 cSt (150 SUS)

Rated flow	30 L/min (8 USgpm)
Max relief pressure	350 bar (5000 psi)
Max load induced pressure	270 bar (4000 psi)
Cartridge material	Working parts hardened and ground steel. External surfaces zinc plated.
Standard housing material	Aluminum (up to 210 bar). Add suffix "377" for steel option.
Mounting position	Unrestricted
Cavity	A6610 (See Section M)
Torque cartridge into cavity	45 Nm (33 lbs ft)
Weight	1CER30 0.15 kg (0.33 lbs) 1CER35 0.41 kg (0.90 lbs) 1CEER34 0.90 kg (1.98 lbs)
Seal kits	SK395 (Nitrile) SK395V (Viton®)
Filtration	Cleanliness code 18/13 (25 micron nominal)
Temperature range	-30°C to +90°C (-22° to +194°F)
Internal leakage	0.3 milliliters/min nominal (5 dpm)
Nominal viscosity range	5 to 500 cSt

Viton is a registered trademark of E.I. DuPont.

Description

The 1CER series overcenter valve performs all duties of a regular overcenter but is able to relieve and stay open irrespective of downstream pressure. This enables the valve to operate when used with a closed center directional valve which has service line reliefs. The poppet is pressure balanced, preventing relief setting increase due to back pressure.

Pressure drop

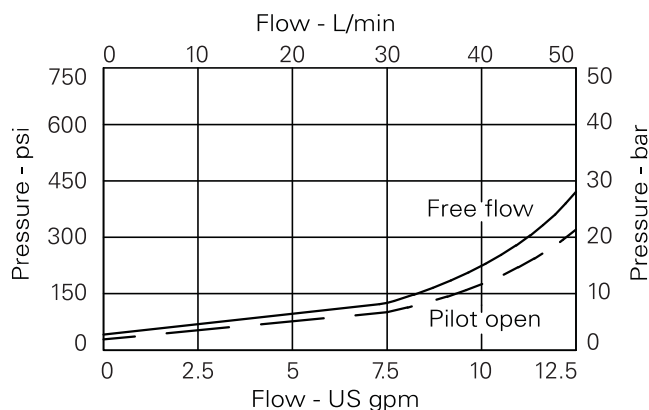

Where measurements are critical request certified drawings. We reserve the right to change specifications without notice.

1CER30 - Overcenter valve

Part balanced, pilot assisted relief with check
30 L/min (8 USgpm) • 270 bar (4000 psi)

Model code

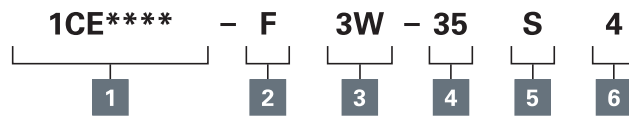

1 Basic code

- 1CER30 - Cartridge only
- 1CER35 - Cartridge and body
- 1CEER34 - Cartridges and dual body

2 Adjustment

- F - Screw adjustment
 - N - Fixed - State pressure setting required.
- For fixed versions add setting in 10 bar increments to end of part number. Subject to a ±10% tolerance.

3 Port sizes - bodied valves only

Code	Port size	Housing number			
		Aluminum single	Steel single	Aluminum dual	Steel dual
Body Only					
3W	3/8" BSP Valve & Cyl Port 1/4" BSP Pilot Port	B6743	B12823	B6836	B13803
6T	3/8" SAE Valve & Cyl Port 1/4" SAE Pilot Port	B10536		B10805	
8T	1/2" SAE Valve & Cyl Port 1/4" SAE Pilot Port	B7884	B11811	B30237	B11812

4 Pressure range

@ 4.8 L/min

- Note: Code based on pressure in bar.
- 35 - 100-350 bar. Std setting 210 bar
- Std setting made at 4.8 L/min

5 Seals

- S - Nitrile
- SV - Viton

6 Pilot ratio

- 2 - 2.5:1
- 4 - 4:1

Dimensions

mm (inch)

Cartridge only

Basic Code
1CER30

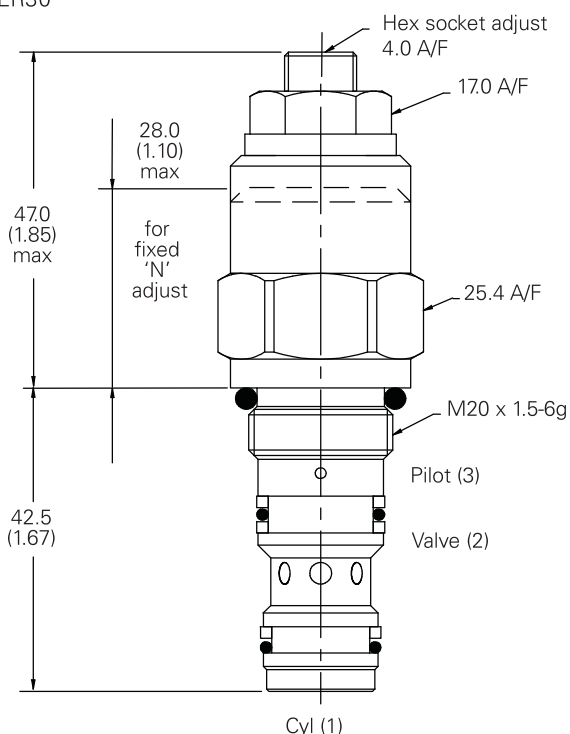

Note: For applications above 210 bar - please consult our technical department or use the steel body option

Note: Tightening torque of "F" adjuster locknut - 20 to 25 Nm

Single valve

3/8". 1/2" Ports
Basic Code 1CER35

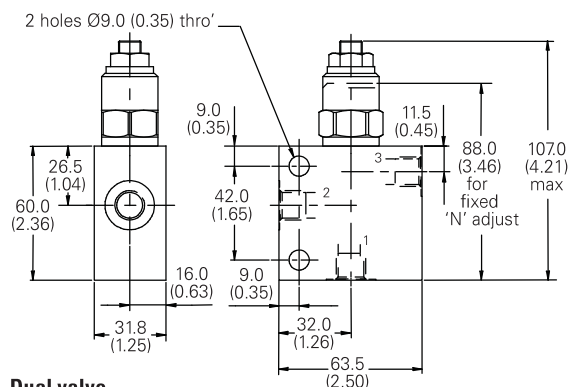

Dual valve

3/8". 1/2" Ports
Basic Code 1CEER34
(Internally Cross Piloted)

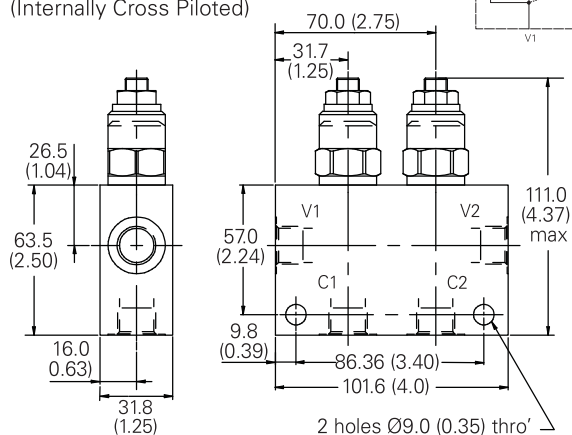

Where measurements are critical request certified drawings. We reserve the right to change specifications without notice.