

Type VBPDL pilot operated check valves

- Double acting

Technical specifications and diagrams are measured with mineral oil of 46 cSt viscosity at 40°C (104°F) temperature.

	VBPDL 14	VBPDL VP 38	VBPDL 38	VBPDL VP 12	VBPDL 12	VBPDL 34	
Nominal flow	30 l/min (7.9 US gpm)		50 l/min (13.2 US gpm)		80 l/min (21.1 US gpm)	120 l/min (31.7 US gpm)	
Max. pressure	350 bar (5100 psi)		300 bar (4350 psi)		300 bar (4350 psi)	300 bar (4350 psi)	
Oil leakage	0.25 cm ³ /min (0.015 in ³ /min) at 210 bar (3050 psi)						
Fluid	mineral based oil						
Viscosity	10-200 cSt						
Max. level of contamination	18/16/13 ISO4406						
Fluid temperature	with NBR seals from -20°C (-4°F) to 80°C (176°F)						
Environmental temp. for working conditions	from -40°C (-40°F) to 100°C (212°F)						
Weight	Steel	0.68 kg (1.5 lb)	0.63 kg (1.39 lb)	0.97 kg (2.14 lb)	0.9 kg (1.98 lb)	1.69 kg (3.72 lb)	3.06 kg (6.75 lb)

NOTE - For different conditions, please contact Walvoil Sales Dpt.

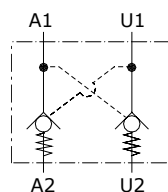

Dimensions

Valve type	All ports
VBPDL 14	G1/4
VBPDL VP 38	G3/8
VBPDL 38	G3/8
VBPDL VP 12	G1/2
VBPDL 12	G1/2
VBPDL 34	G3/4

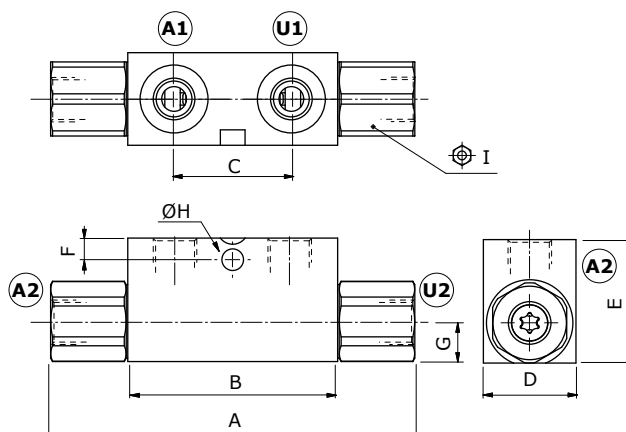

Dimensions are in mm-in

Valve type	A max.	B	C	D	E	F	G	ØH	⊕I
VBPDL 14	118-4.64	68-2.68	38-1.50	30-1.18	40-1.57	7-0.27	13-0.51	8-0.31	24
VBPDL VP 38	118-4.64	68-2.68	38-1.50	30-1.18	40-1.57	7-0.27	13-0.51	8-0.31	24
VBPDL 38	144-5.67	80-3.15	40-1.57	30-1.18	50-1.97	15-0.59	16-0.63	8.5-0.33	27
VBPDL VP 12	144-5.67	80-3.15	40-1.57	30-1.18	50-1.97	15-0.59	16-0.63	8.5-0.33	27
VBPDL 12	171-6.73	90-3.54	40-1.57	40-1.57	60-2.36	15-0.59	20-0.79	8.5-0.33	30
VBPDL 34	196 ⁽¹⁾ -7.72 ⁽¹⁾	107-4.21	60-2.36	50-1.97	70-2.75	16-0.63	23-0.90	8.5-0.33	41

NOTE - ⁽¹⁾ Only for 04 SAE 208

Ordering codes and description composition

VBPDL 14 / p4,5 / Pa4 / ac

Port size: 14
Opening pressure: p4,5
Pilot ratio: Pa4
ac

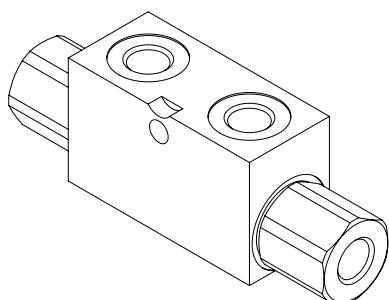

VBPDL Complete valves

TYPE	CODE	DESCRIPTION
VBPDL 14/p4,5/Pa4/ac	1420112100	Steel body, G1/4 port configuration, pilot ratio 1:4.5, opening pressure 4 bar (58 psi)
VBPDL 38/p4/Pa4/ac	1420122100	Steel body, G3/8 port configuration, pilot ratio 1:4, opening pressure 4 bar (58 psi)
VBPDL VP 38/p4/Pa4/ac	1420122101	Steel body, G3/8 port configuration, pilot ratio 1:4.5, opening pressure 4 bar (58 psi)
VBPDL 12/p4/Pa4/ac	1420132100	Steel body, G1/2 port configuration, pilot ratio 1:4, opening pressure 4 bar (58 psi)
VBPDL VP 12/p4/Pa4/ac	1420132101	Steel body, G1/2 port configuration, pilot ratio 1:4, opening pressure 4 bar (58 psi)
VBPDL 34/p4/Pa4/ac	1420142100	Steel body, G3/4 port configuration, pilot ratio 1:4, opening pressure 4 bar (58 psi)

For different configurations or SAE thread please contact our Sales Dpt.

VBPDL 14 pressure drop vs. flow

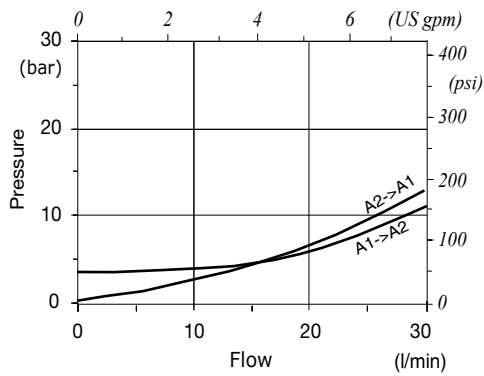

VBPDL 38 pressure drop vs. flow

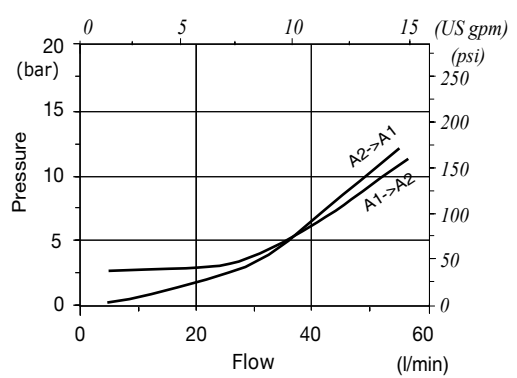

VBPDL 12 pressure drop vs. flow

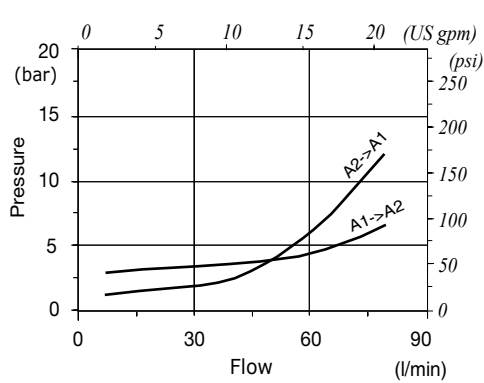

VBPDL 34 pressure drop vs. flow

