

IN-LINE QUICK-EXHAUST VALVES SERIES VSR L

**METAL
WORK**[®]
P N E U M A T I C

The VSR L quick-exhaust valve belongs to the **LINE ON LINE**[®] family, which means it can be connected to all the other components in series or in parallel.

Available in the version for pipe-pipe connection with two push-in fittings, and in the version for thread-pipe connection with a brass nickel-plated male thread and a push-in fitting.

Exhaust can be silenced using a **STAINLESS** steel wire silencer, or conveyed using a push-in fitting.



TECHNICAL DATA		Ø 4 (Ø5/32")	Ø 6	Ø 1/4"	Ø 8 (Ø5/16")	Ø3/8"	Ø10	
Inlet pressure	MPa						0.1 to 1	
	bar						1 to 10	
	psi						14.5 to 145	
Temperature range	°C						- 20 to + 60	
	°F						- 4 to + 140	
Inlet flow rate at 6.3 bar ΔP 1 bar	Nl/min	50	270	270	400	530	530	
Exhaust flow rate at 6.3 bar	Nl/min	100	700	700	1000	1400	1400	
Recommended pipe		Rilsan PA 11 - Nylon 6 - Polyamide 12 - Polypropylene						
Fluid		Lubricated or unlubricated filtered compressed air; if used, must be continuous						
Compatibility with oils		See chapter Z1						

COMPONENTS

- ① Technopolymer body
- ② Nickel-plated brass insert
- ③ NBR valve
- ④ NBR gasket
- ⑤ Technopolymer spring ring
- ⑥ Stainless steel folding spring
- ⑦ Brass or technopolymer locking bushing
- ⑧ Technopolymer release bushing
- ⑨ Stainless steel wire silencer

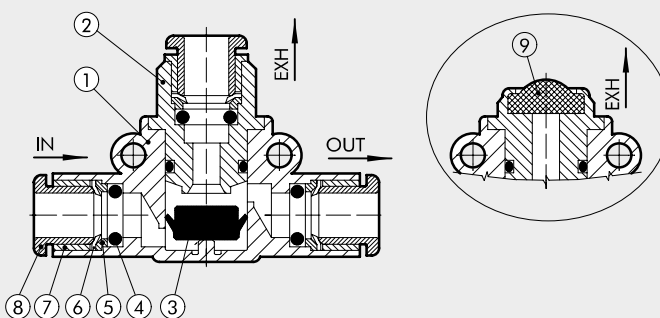

ASSEMBLY OPTIONS

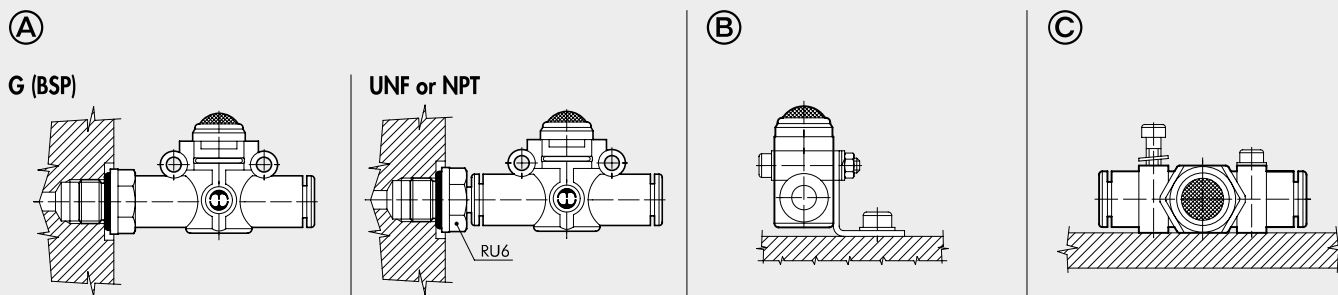

How to mount the VSR L:

- Fig. **A G (BSP)**: With the male threaded port it is possible to mount the VSR L straight onto the actuator.
UNF or NPT: Adding a RU6 fitting, with his male UNF or NPT thread, it is possible to mount the VSR L straight on to the actuator or the control valve.
- Fig. **B**: Fixing to the plate with the special SQU L bracket, except for Ø3/8 and Ø10.
- Fig. **C**: There are two robust rings on the plastic body for fixing the VSR L straight onto the wall.

VSR L PIPE - PIPE, CONVEYED EXHAUST

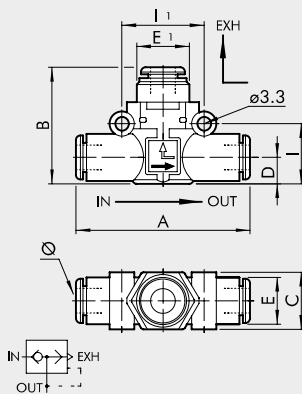

Code	Ref.	Ø	A	B	C	D	E	E1	I	I1
9063001	VSR L Ø4-Ø4-Ø4	4 ▲	41.8	25.8	10.7	5.6	10	9.7	12.8	16
9063016	VSR L Ø6-Ø6-Ø6	6	49.4	30.2	14.7	6.4	11.4	13	14.6	20
9063016U	VSR L Ø1/4-Ø1/4-Ø1/4	1/4	49.4	30.2	14.7	6.4	11.4	13	14.6	20
9063024	VSR L Ø8-Ø8-Ø8	8 ▲	57.3	35.9	18.7	9.1	13.8	15	18.7	24
9063032U	VSR L Ø3/8-Ø3/8-Ø3/8	3/8	65	41.5	21	10.9	16	17	21.4	26
9063032	VSR L Ø10-Ø10-Ø10	10	65	41.5	21	10.9	16	17	21.4	26

▲ Ø4 = Ø5/32"; Ø8 = Ø5/16"

VSR L PIPE - PIPE, SILENCED EXHAUST

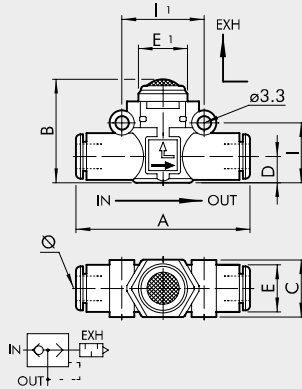

Code	Ref.	Ø	A	B	C	D	E	E1	I	I1
9063101	VSR L Ø4-Ø4-SIL	4 ▲	41.8	19.8	10.7	5.6	10	10	12.8	16
9063116	VSR L Ø6-Ø6-SIL	6	49.4	25.5	14.7	6.4	11.4	14	14.6	20
9063116U	VSR L Ø1/4-Ø1/4-SIL	1/4	49.4	25.5	14.7	6.4	11.4	14	14.6	20
9063124	VSR L Ø8-Ø8-SIL	8 ▲	57.3	31.5	18.7	9.1	13.8	18	18.7	24
9063132U	VSR L Ø3/8-Ø3/8-SIL	3/8	65	37	21	10.9	16	17	21.4	26
9063132	VSR L Ø10-Ø10-SIL	10	65	37	21	10.9	16	17	21.4	26

▲ Ø4 = Ø5/32"; Ø8 = Ø5/16"

VSR L PIPE - G (BSP) THREAD, CONVEYED EXHAUST

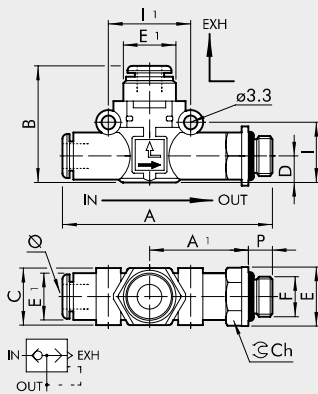

Code	Ref.	Ø	F	P	A	A1	B	C	D	E	E1	E2	I	I1	Ch
9063201	VSR L Ø4-M5-Ø4	4 ▲	M5	4	47.7	22.7	25.8	10.7	5.6	9.9	10	9.7	12.8	16	9
9063202	VSR L Ø4-1/8-Ø4	4 ▲	1/8	6	50.6	24.6	25.8	10.7	5.6	14	10	9.7	12.8	16	12
9063208	VSR L Ø6-1/8-Ø6	6	1/8	6	58.5	27.8	30.2	14.7	6.4	14	11.4	13	14.6	20	12
9063209	VSR L Ø6-1/4-Ø6	6	1/4	8	61.5	28.8	30.2	14.7	6.4	18	11.4	13	14.6	20	14
9063210	VSR L Ø8-1/8-Ø8	8 ▲	1/8	6	66.2	31.8	35.9	18.7	9.1	15	13.8	15	18.7	24	14
9063211	VSR L Ø8-1/4-Ø8	8 ▲	1/4	8	70.6	34.2	35.9	18.7	9.1	18	13.8	15	18.7	24	14
9063212	VSR L Ø8-3/8-Ø8	8 ▲	3/8	9	72.2	34.8	35.9	18.7	9.1	22	13.8	15	18.7	24	17
9063215	VSR L Ø10-1/4-Ø10	10	1/4	8	79.9	39.2	41.5	21	10.9	18	16	17	21.4	26	16
9063216	VSR L Ø10-3/8-Ø10	10	3/8	9	81.2	40.4	41.5	21	10.9	20	16	17	21.4	26	17
9063217	VSR L Ø10-1/2-Ø10	10	1/2	11	83.7	40	41.5	21	10.9	26	16	17	21.4	26	22

▲ Ø4 = Ø5/32"; Ø8 = Ø5/16"

VSR L PIPE - G (BSP) THREAD, SILENCED EXHAUST

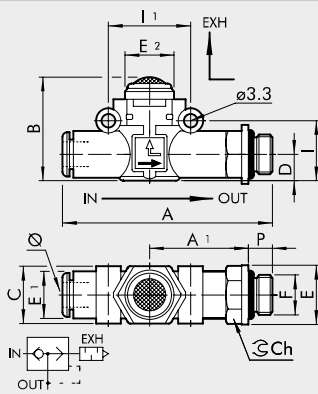

Code	Ref.	Ø	F	P	A	A1	B	C	D	E	E1	E2	I	I1	Ch
9063301	VSR L Ø4-M5-SIL	4 ▲	M5	4	46.7	22.7	19.8	10.7	5.6	9.9	10	10	12.8	16	9
9063302	VSR L Ø4-1/8-SIL	4 ▲	1/8	6	50.6	24.6	19.8	10.7	5.6	14	10	10	12.8	16	12
9063308	VSR L Ø6-1/8-SIL	6	1/8	6	58.5	27.8	25.5	14.7	6.4	14	11.4	14	14.6	20	12
9063309	VSR L Ø6-1/4-SIL	6	1/4	8	61.5	28.8	25.5	14.7	6.4	18	11.4	14	14.6	20	14
9063310	VSR L Ø8-1/8-SIL	8 ▲	1/8	6	66.2	31.8	31.5	18.7	9.1	15	13.8	18	18.7	24	14
9063311	VSR L Ø8-1/4-SIL	8 ▲	1/4	8	70.6	34.2	31.5	18.7	9.1	18	13.8	18	18.7	24	14
9063312	VSR L Ø8-3/8-SIL	8 ▲	3/8	9	72.2	34.8	31.5	18.7	9.1	22	13.8	18	18.7	24	17
9063315	VSR L Ø10-1/4-SIL	10	1/4	8	79.9	39.2	37	21	10.9	18	16	17	21.4	26	16
9063316	VSR L Ø10-3/8-SIL	10	3/8	9	81.2	40.4	37	21	10.9	20	16	17	21.4	26	17
9063317	VSR L Ø10-1/2-SIL	10	1/2	11	83.7	40	37	21	10.9	26	16	17	21.4	26	22

▲ Ø4 = Ø5/32"; Ø8 = Ø5/16"