



# CHM3

## PILOT OPERATED CHECK VALVE

### SERIES 10

#### MODULAR VERSION ISO 4401-03

**p** max 350 bar  
**Q** max (see table of performances)

#### MOUNTING SURFACE

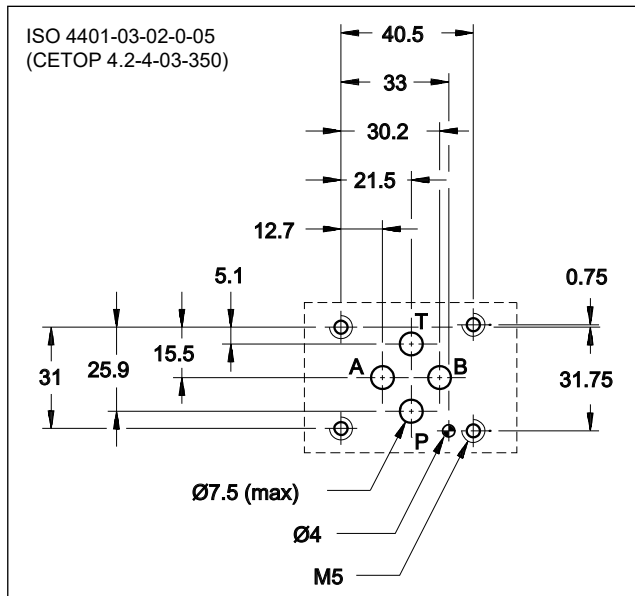

#### OPERATING PRINCIPLE

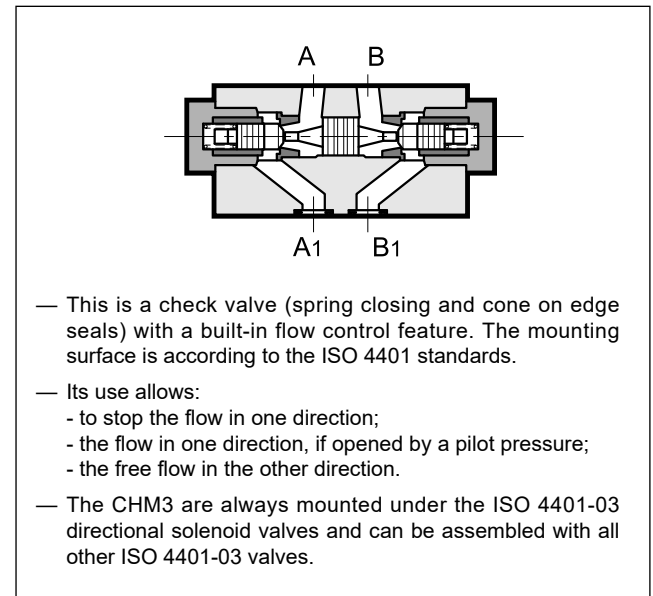

#### PERFORMANCES (measured with mineral oil of viscosity 36cSt at 50°C)

Maximum operating pressure	bar	350
Check valve cracking pressure		3
Maximum flow rate in controlled lines	l/min	50
Maximum flow rate in the free lines		75
Ratio between the pressure in the locked chambers and the piloting pressure		3.4:1
Ambient temperature range	°C	-20 / +60
Fluid temperature range	°C	-20 / +80
Fluid viscosity range	cSt	10 ÷ 400
Fluid contamination degree	According to ISO 4406:1999 class 20/18/15	
Recommended viscosity	cSt	25
Mass	kg	1.3

#### HYDRAULIC SYMBOLS

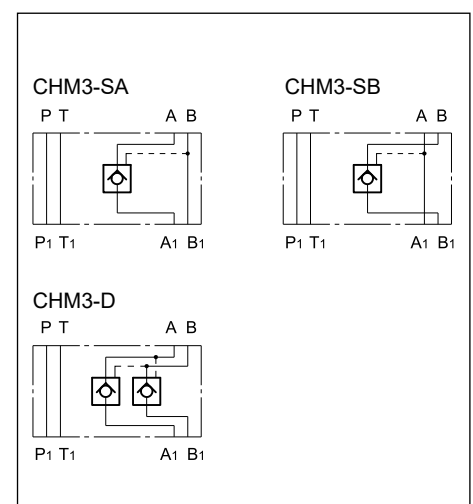

## 1 - IDENTIFICATION CODE

<b>C</b>	<b>H</b>	<b>M</b>	<b>3</b>	<b>-</b>	<b>/</b>	<b>10</b>		
----------	----------	----------	----------	----------	----------	-----------	--	--

Pilot operated check valve \_\_\_\_\_

Modular version \_\_\_\_\_

ISO 4401-03 size \_\_\_\_\_

Configurations: \_\_\_\_\_

**D** = seal on lines A and B of the actuator  
**SA** = seal on line A of the actuator  
**SB** = seal on line B of the actuator

Option:  
**/ W7** = Zinc-nickel surface treatment (see **NOTE**). Omit if not required.

Seals:  
**N** = NBR seals for mineral oil (**standard**)  
**V** = FPM seals for special fluids

Series No. (the overall and mounting dimensions remain unchanged from 10 to 19)

**NOTE:** The standard valve is supplied with surface treatment of phosphating black. The zinc-nickel finishing on the valve body makes the valve suitable to ensure a salt spray resistance up to **600** hours. (test operated according to UNI EN ISO 9227 standards and test evaluation operated according to UNI EN ISO 10289 standards).

## 2 - CHARACTERISTIC CURVES

(values obtained with viscosity of 36 cSt at 50°C)

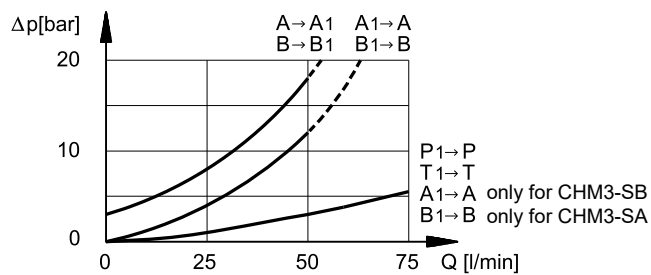

## 3 - HYDRAULIC FLUIDS

Use mineral oil-based hydraulic fluids HL or HM type, according to ISO 6743-4. For these fluids, use NBR seals. For fluids HFDR type (phosphate esters) use FPM seals (code V). For the use of other kinds of fluid such as HFA, HFB, HFC, please consult our technical department.

Using fluids at temperatures higher than 80 °C causes a faster degradation of the fluid and of the seals characteristics. The fluid must be preserved in its physical and chemical characteristics.

## 4 - OVERALL AND MOUNTING DIMENSIONS

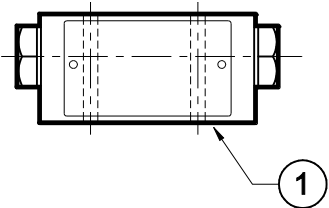
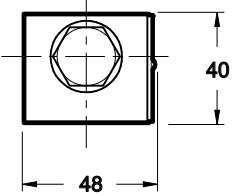
dimensions in mm

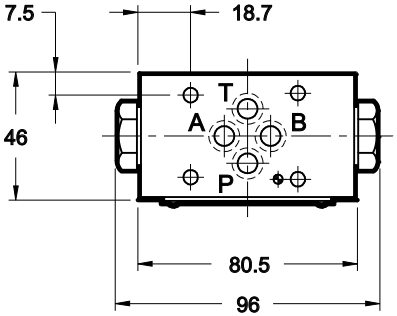

1	Mounting surface with sealing rings: 4 OR type 2037 (9.25x1.78) - 90 Shore
---	---