

HY3

GROUP 3 EXTERNAL
GEAR PUMPS AND MOTORS

From 22 to 61 cc/rev
Up to 280 bar

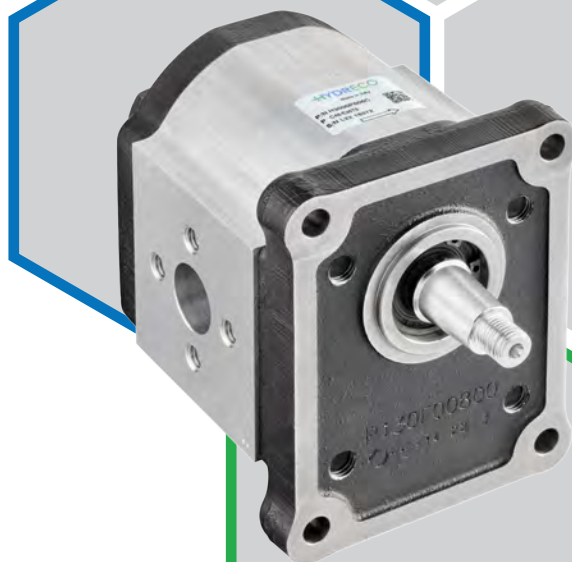

Hydreco is pleased to introduce a brand new range of gear pumps and motors. Based on the experience and knowledge acquired over many years of engineering and manufacturing, the HY series is provided with an aluminum alloy housing, two gear wheels supported by sleeve bearings and cast iron flange and cover.

The HY3 series, available as pumps and motors, offers high efficiency, low noise level and can be applied in standard and heavy duty application, thanks to the high reliability and the accuracy of design and production. The pumps can be supplied as single, or as multiple units with a huge variety of options and flanges, shafts and ports, providing the right setup on each application. Feel free to contact your Hydreco representative to find out and to get the proper support in your selection.

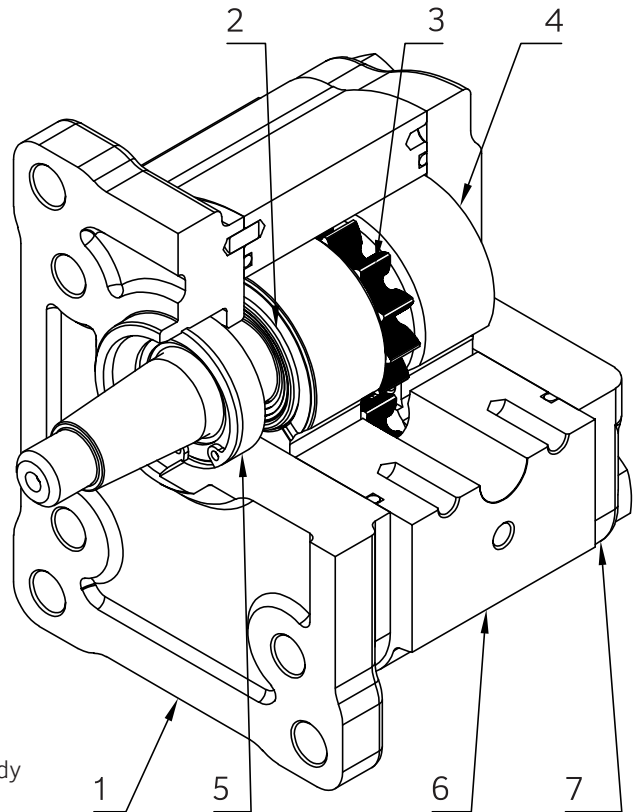

- 1 - Cast Iron Flange
- 2 - Gaskets
- 3 - Gears
- 4 - Bushings
- 5 - Shaft Seal
- 6 - Aluminium Alloy Body
- 7 - Cast Iron Cover

Displacements

From 22 cm³/ rev to 61 cm³/rev
From 1.34 in³/rev to 3.72 in³/rev

Pressures

Max continuous 250 bar (3625 psi)
Max intermittent 270 bar (3915 psi)
Max peak 280 bar (4060 psi)

Max Speed

3000 rpm



- H31PA0030C = Pump / Motor part number
- P or M = Pump or Motor
- P C22-E30T3 = Abbreviate model code - Ex. Pump 39 cc - European Standard Clockwise
- D243853 06325 = Serial number - Eg. D (month) - 24 (year) - 3853 (Production order) - 06325 (Id. number)
- Arrow = Direction of rotation
- QR Code = Complete model code

Hydreco is pleased to introduce a brand new range of gear pumps and motors. Based on the experience and knowledge acquired over many years of engineering and manufacturing, the HY series is provided with an aluminum alloy housing, two gear wheels supported by sleeve bearings and cast iron flange and cover.

The HY3 series, available as pumps and motors, offers high efficiency, low noise level and can be applied in standard and heavy duty application, thanks to the high reliability and the accuracy of design and production. The pumps can be supplied as single, or as multiple units with a huge variety of options and flanges, shafts and ports, providing the right setup on each application. Feel free to contact your Hydreco representative to find out and to get the proper support in your selection.

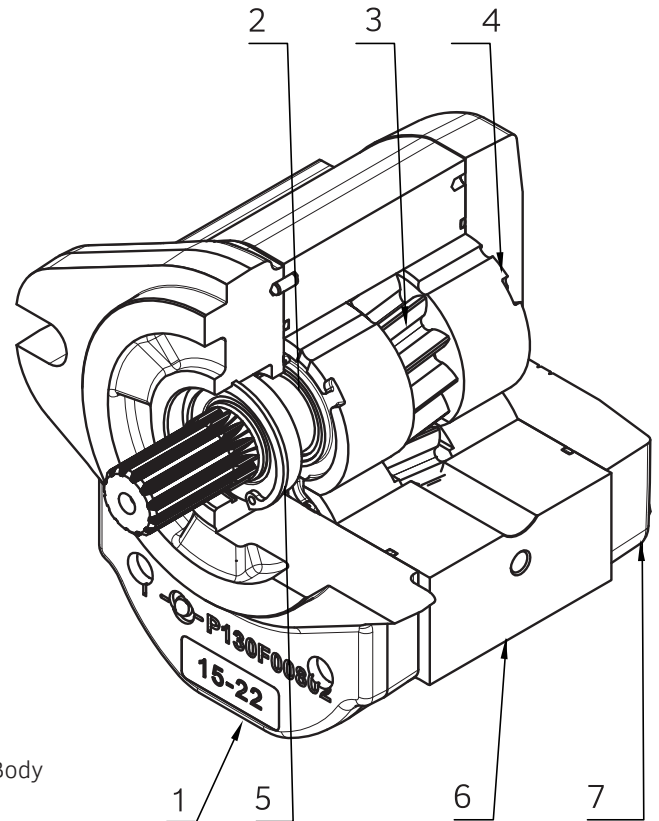

- 1 - Cast Iron Flange
- 2 - Gaskets
- 3 - Gears
- 4 - Bushings
- 5 - Shaft Seal
- 6 - Aluminium Alloy Body
- 7 - Cast Iron Cover

Displacements

From 22 cm³/ rev to 61 cm³/rev
From 1.34 in³/rev to 3.72 in³/rev

Pressures

Max continuous 250 bar (3625 psi)
Max intermittent 270 bar (3915 psi)
Max peak 280 bar (4060 psi)

Max Speed

3000 rpm



- H31PA0005C = Pump / Motor part number
- P or M = Pump or Motor
- P C52-B22P = Abbreviate model code - Ex. Single pump 52 cc - SAE B flange, parallel shaft (American)
- D243854 06326 = Serial number - Eg. D (month) - 24 (year) - 3854 (Production order) - 06326 (Id. number)
- Arrow = Direction of rotation
- QR Code = Complete model code

ORDERING CODE IDENTIFICATION FOR SINGLE PUMPS EUROPEAN STANDARDS

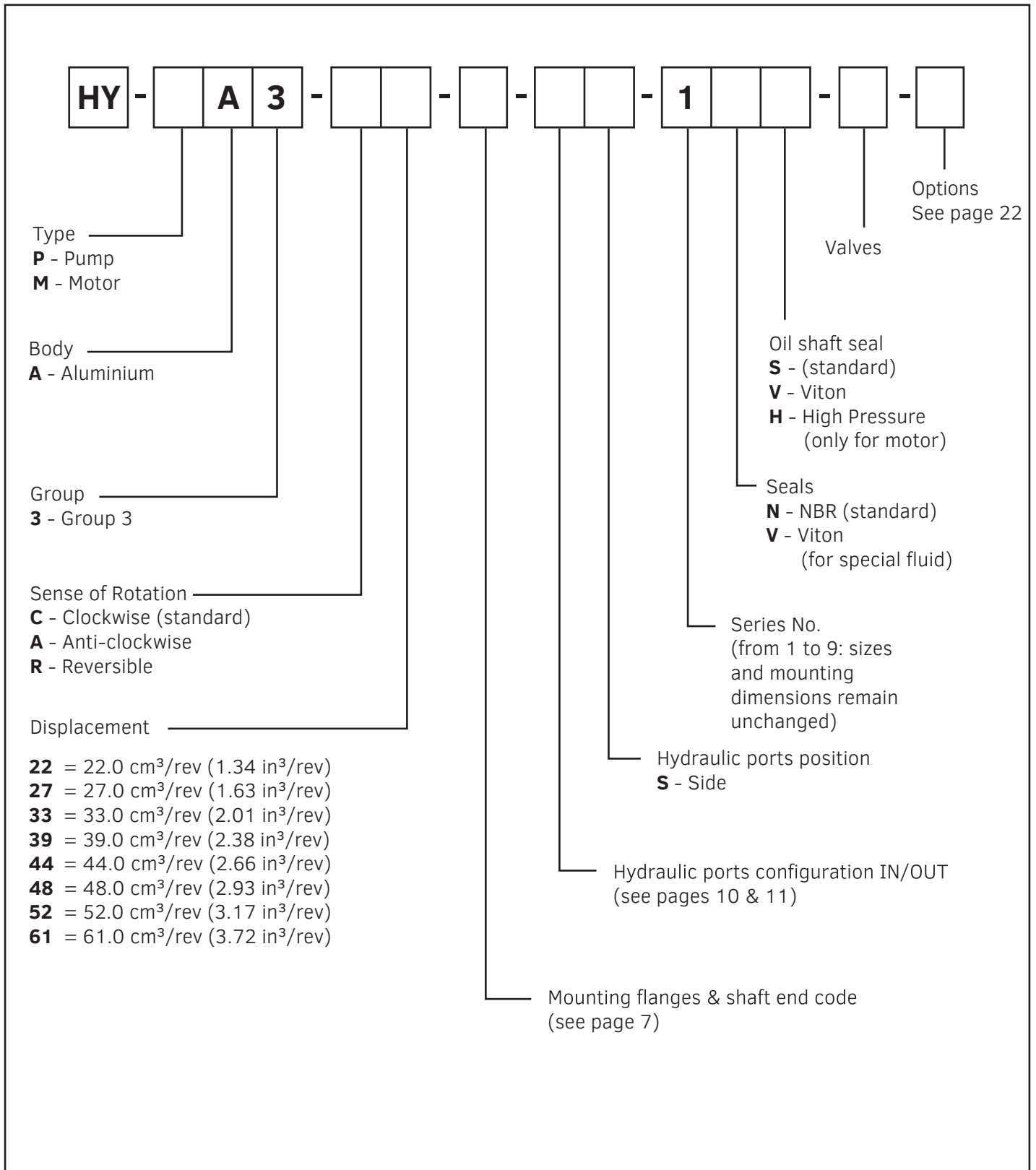

Example

HY-PA3-C22-E30T3-FE4/3S-1NS

GR3 single pump - clockwise rotation - 22cc - european flange with tapered shaft 1:8 - european flanged ports

ORDERING CODE IDENTIFICATION FOR SINGLE PUMPS AMERICAN STANDARDS

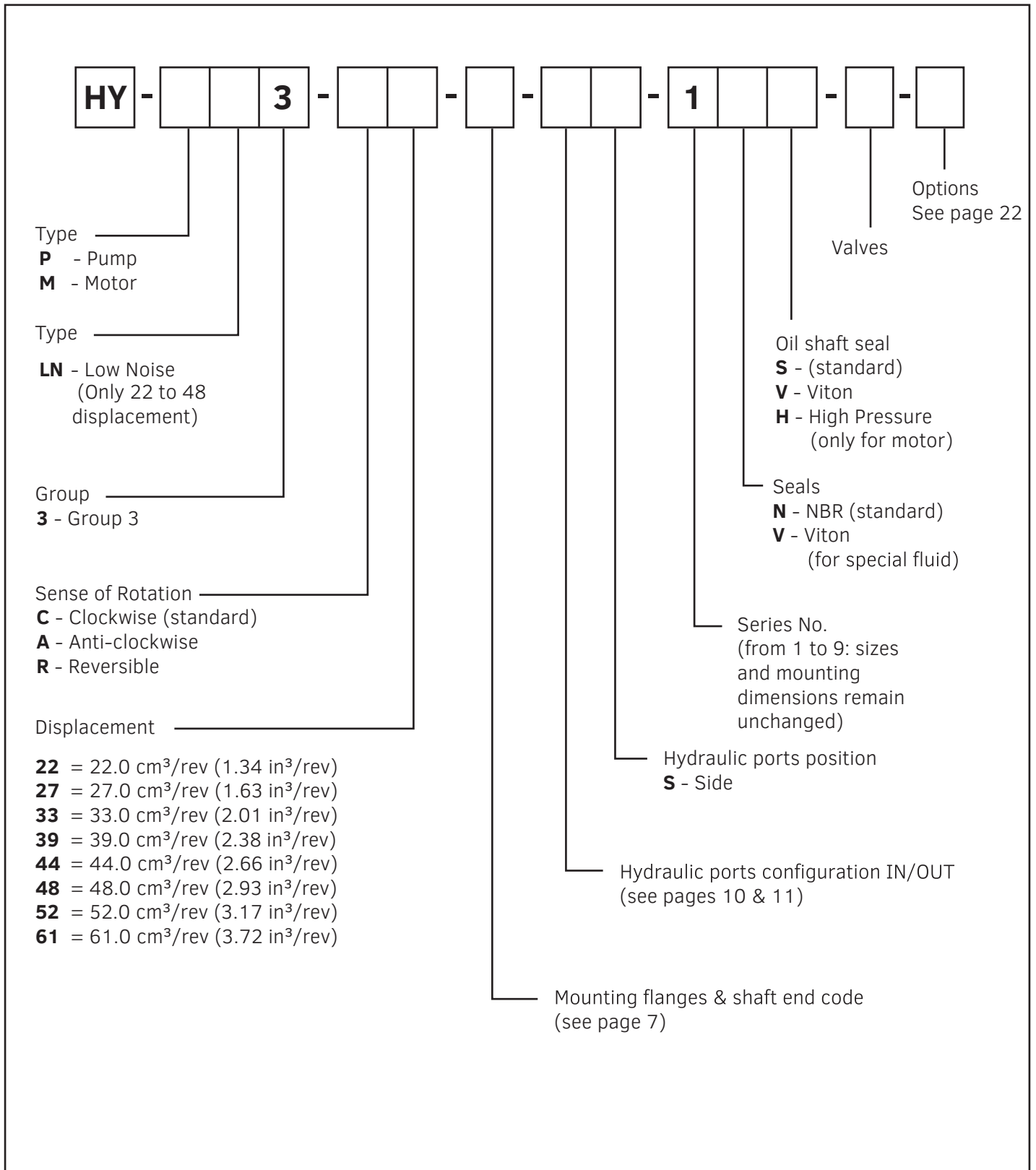

Example

HY-PLNA3-C33-B13T-U4/3S-1NS

GR3 single pump - clockwise rotation - 33cc - SAE B flange - 13T splined shaft - SAE threaded ports

ORDERING CODE IDENTIFICATION FOR ADDITIONAL STAGES ON MULTIPLE PUMPS

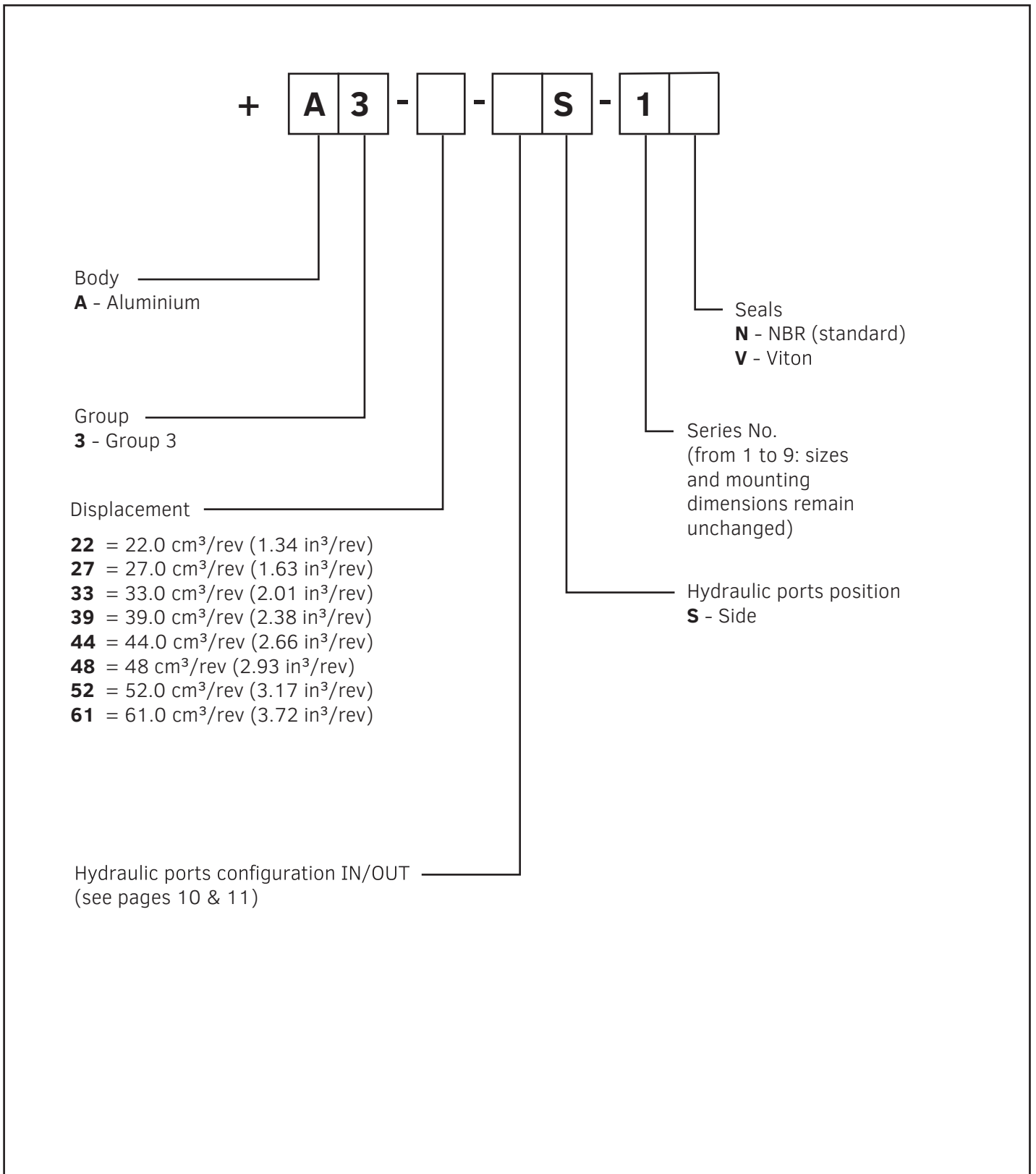

Example

HY-PA3-C27-E30T3-FE4/3S-1NS+A3-22-FE4/3S-1N

GR3 double pump - clockwise rotation - 27cc + 22cc - european flange with tapered shaft 1:8 - european flanged ports

EUROPEAN standard CODES	FLANGE	SHAFT
E30T3	E30 = European flange pilot \varnothing 50.8	T3 = tapered shaft 1:8 M14

AMERICAN standard CODES	FLANGE	SHAFT
B13T	B = SAE B flange \varnothing 101.6	13T = Splined shaft 13T 16/32
B15T	B = SAE B flange \varnothing 101.6	15T = Splined shaft 15T 16/32
B22P	B = SAE B flange \varnothing 101.6	22P = Parallel shaft \varnothing 22.22

For other configurations than those indicated, please contact Hydreco technical support.

GROUP	SIZE	DISPLACEMENT cm ³ /rev (in ³ /rev)	MAX PRESSURE bar (psi)			SPEED rpm	
			P1	P2	P3	min	max
HY3	22	22 (1.34)	250 (3625)	270 (3915)	280 (4060)	500	3000
	27	27 (1.63)	250 (3625)	270 (3915)	280 (4060)	500	3000
	33	33 (2.01)	240 (3480)	260 (3770)	270 (3915)	500	3000
	39	39 (2.38)	240 (3480)	260 (3770)	270 (3915)	500	3000
	44	44 (2.68)	230 (3335)	250 (3625)	260 (3770)	500	3000
	48	48 (2.93)	210 (3045)	230 (3335)	240 (3480)	500	2500
	52	52 (3.17)	210 (3045)	230 (3335)	240 (3480)	500	2500
	61	61 (3.72)	190 (2755)	210 (3045)	220 (3190)	500	2500

The data in the table refer to unidirectional pumps and motors.
 The maximum pressures of reversible pumps and motors are 15% lower than unidirectional ones.
 For different working conditions please contact Hydreco technical support.
 Please note: displacement 73 and 88 are available for quantities.

GENERAL CHARACTERISTICS

ROTATION DIRECTION

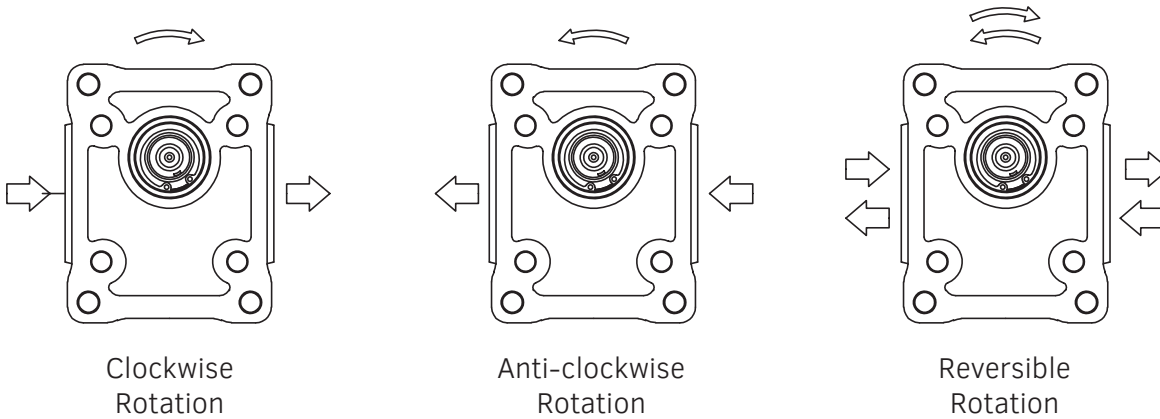

DEFINITION OF PRESSURES

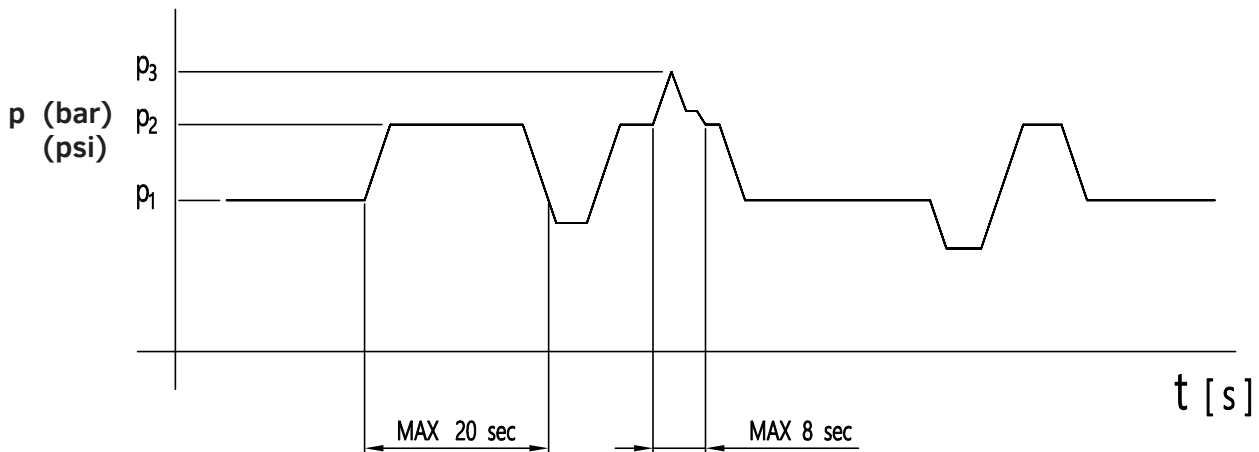

- p₁** Max continuous pressure
- p₂** Max intermittent pressure
- p₃** Max peak pressure

GENERAL CHARACTERISTICS

It is essential that pumps are installed so that they can always fill with fluid. 'HY' Series pumps inlet porting is designed to facilitate full volume fill but the following machine design recommendations should be followed.

Direction of rotation (Viewed from shaft end)	Clockwise (C) – Anticlockwise (A) – Reversible (R)
Range inlet pressure – pump	0.7 ÷ 3 bar (10 ÷ 43 psi)
Max back pressure on the unidirectional motors and reversible with internal drainage	P ₁ (continue) max 5 bar (72 psi) P ₂ (for 20 sec) max 8 bar (115 psi) P ₃ (for 5 sec) max 15 bar (215 psi)
Reversible Motor Max pressure in drain	5 bar
Temperature fluid (MIN, MAX, PEAK) °C	-25, 80, 100 NBR -25, 110, 125 VITON
Range of viscosity	From 10 to 100 mm ² /s (cSt) IDEAL Up to 750 mm ² /s (cSt) RECOMMENDED Up to 1000 mm ² /s (cSt) START
Fluid type	Mineral oil

RECOMMENDED FILTRATION

Working pressure bar (psi)	$\Delta p < 140$ (2030)	140 (2030) < $\Delta p < 210$ (3040)	$\Delta p > 210$ (3040)
Class contamination NAS 1638	10	9	8
Class contamination ISO 4406:1999	21/19/16	20/18/15	19/17/14

- Q = flow rate (L/min)
- V = displacement (cm³/rev)
- n = speed (min⁻¹)
- M = torque (Nm)
- P = power (kW)
- Δp = pressure (bar)

	PUMPS	MOTORS
PERFORMANCE		
η_v = volumetric efficiency	≈ 0.96	≈ 0.95
η_{hm} = hydro-mechanical efficiency	≈ 0.88	≈ 0.85
η_t = total efficiency	≈ 0.84	≈ 0.81

FLANGES OPTIONS

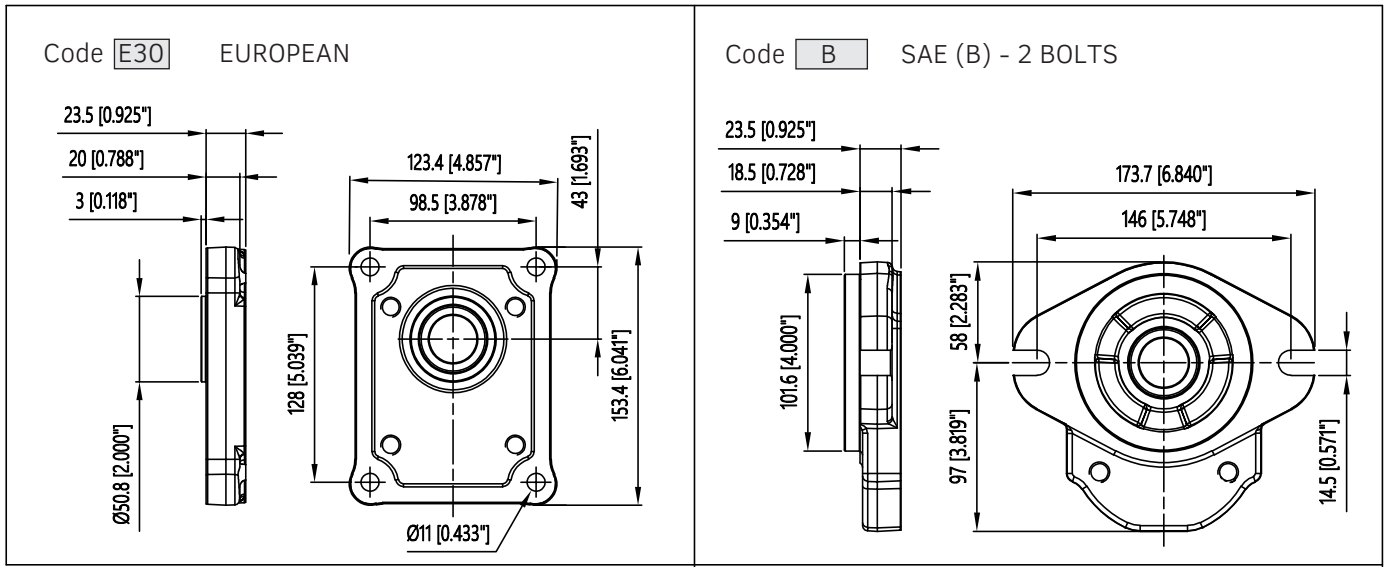

SHAFT OPTIONS

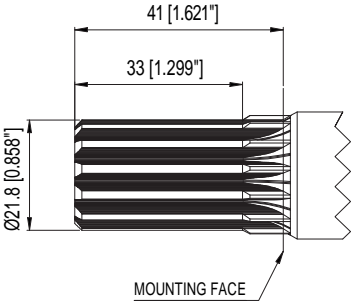
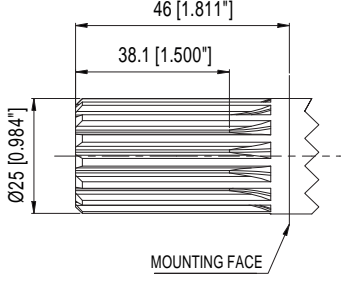
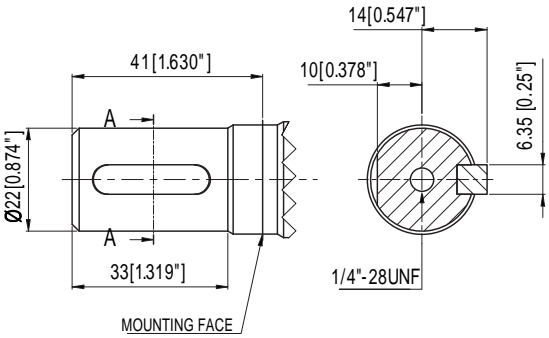
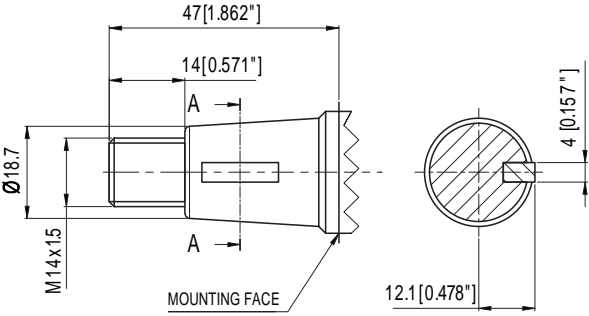
<p>Code 13T SAE (B) Ø 22 spline</p> <p>Involute Spline 13 teeth – 16/32 DP Flat root, side fit 30 deg pressure angle</p>  <p>Max Torque = 290 Nm (2567 lbf in)</p>	<p>Code 15T SAE (B) Ø 25 spline</p> <p>Involute Spline 15 teeth – 16/32 DP Flat root, side fit 30 deg pressure angle</p>  <p>Max Torque = 400 Nm (3540 lbf in)</p>
<p>Code 22P SAE (B) 22.22 mm parallel</p>  <p>Max Torque = 200 Nm (1770 lbf in)</p>	<p>Code T3 European Tapered 1:8</p>  <p>Max Torque = 240 Nm (2124 lbf in)</p>

SHAFT OIL SEAL

Code **13T** **22P** **T3** = **25 x 40 x 7**

Code **15T** = **28 x 40 x 7**

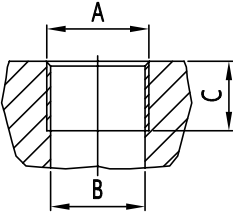
BSPP THREADED PORTS (B) Compliant with ISO 228	Ordering Code	Dimension mm (inches)			Tightening Torque Nm [lbf in]	
		A	B	C	Low Pressure	High Pressure
	3	3/4"	24 (0.944)	18 (0.708)	30 [265]	80 [710]
	4	1"	30 (1.181)	22 (0.866)	50 [440]	130 [1060]
	5	1 1/4"	39 (1.535)	22 (0.866)	60 [530]	170 [1500]
	6	1 1/2"	45 (1.771)	24 (0.944)	70 [620]	210 [1850]

STANDARD PORT CONFIGURATION				
CODE	SUCTION	PRESSURE	POSITION	SIZE
B4/3S	4=1" BSPP	3 = 3/4" BSPP	S = SIDE	22 to 52
B5/4S	5=1 1/4" BSPP	4 = 1" BSPP	S = SIDE	61

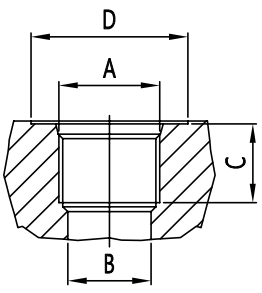
SAE THREADED PORTS (U) Compliant with SAE J514	Ordering Code	Dimensions mm (inches)				Tightening Torque Nm [lbf in]	
		A	B	C	D	Low Pressure	High Pressure
	3	1 1/16" - 12 UNF	24 (0.944)	20 (0.787)	42 (1.654)	40 [355]	120 [1060]
	4	1 5/16" - 12 UNF	30 (1.200)	20 (0.787)	49 (1.929)	60 [530]	170 [1500]
	5	1 5/8" - 12 UNF	39 (1.539)	20 (0.787)	58 (2.283)	70 [620]	210 [1850]
	6	1 7/8" - 12 UNF	45 (1.771)	20 (0.787)	65 (2.559)	100 [885]	270 [2390]

STANDARD PORTS CONFIGURATION				
CODE	SUCTION	PRESSURE	POSITION	SIZE
U4/3S	1 5/16" = 12 UNF	1 1/16" = 12 UNF	S = SIDE	22 to 33
U5/4S	1 5/8" = 12 UNF	1 5/16" = 12 UNF	S = SIDE	39 to 52
U6/5S	1 7/8" = 12 UNF	1 5/8" = 12 UNF	S = SIDE	61

INLET PORTS = For multiple pumps with single inlet please contact Hydreco technical support

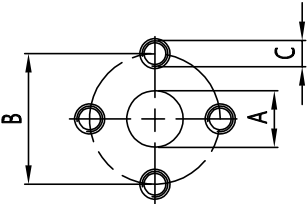
EUROPEAN FLANGED PORTS (FE)	Ordering Code	Dimensions mm (inches)			Tightening Torque Nm [lbf in]	
		A	B	C	Low Pressure	High Pressure
	3	20 (0.787)	40 (1.574)	M8	15 [130]	15 [130]
	4	27 (1.063)	51 (2.007)	M10	20 [175]	30 [265]
	5	33 (1.299)	62 (2.440)	M12	25 [220]	50 [440]

STANDARD PORTS CONFIGURATION				
CODE	SUCTION	PRESSURE	POSITION	SIZE
FE4/3S	4 = Ø27 mm	3 = Ø20 mm	SIDE (fixed)	22 to 52
FE5/4S	5 = Ø33 mm	4 = Ø27 mm	SIDE (fixed)	61

INLET PORTS = For multiple pumps with single inlet please contact Hydreco technical support

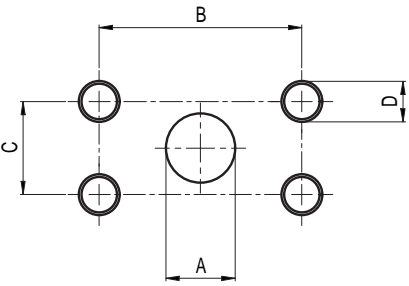
SAE FLANGED PORTS - 51B (SM)	Ordering Code	Dimensions mm (inches)				Tightening Torque Nm [lbf in]	
		A	B	C	D	Low Pressure	High Pressure
	2	12.5 (0.472)	38.1 (1.50)	17.5 (0.687)	M8	15 [133]	20 [180]
	3	19 (0.748)	47.6 (1.874)	22.2 (0.874)	M10	20 [180]	35 [320]
	4	25.4 (1.00)	52.4 (2.063)	26.2 (1.031)	M10	20 [180]	35 [320]
	5	30.5 (1.201)	58.7 (2.311)	30.2 (1.187)	M10	20 [180]	35 [320]
	6	39.3 (1.547)	69.8 (2.748)	35.7 (1.405)	M12	30 [270]	60 [540]

STANDARD PORTS CONFIGURATION				
CODE	SUCTION	PRESSURE	POSITION	SIZE
SM 3/2	3 = Ø19 mm	2 = Ø12.5 mm	SIDE (fixed)	22
SM 4/3	4 = Ø25.4 mm	3 = Ø19 mm	SIDE (fixed)	27 to 33
SM 5/4	5 = Ø30.5 mm	4 = Ø25.4 mm	SIDE (fixed)	39 to 52
SM 6/5	6 = Ø39.3 mm	5 = Ø30.5 mm	SIDE (fixed)	61

INLET PORTS = For multiple pumps with single inlet please contact Hydreco technical support

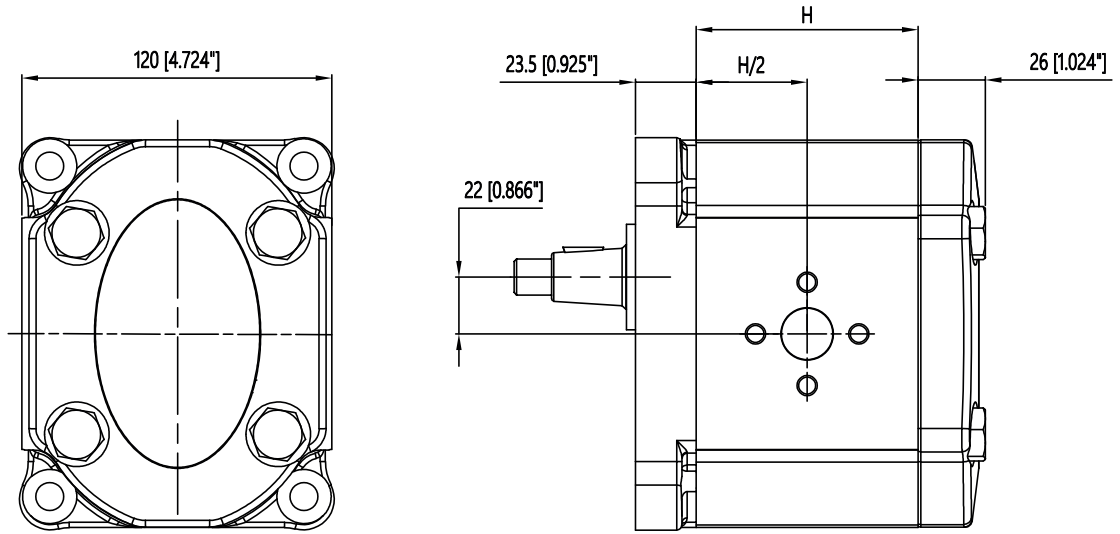

UNIDIRECTIONAL COVER

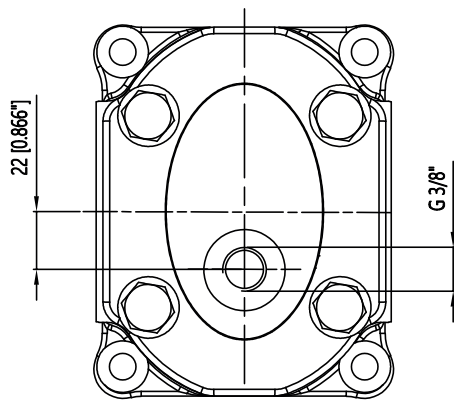

REVERSIBLE COVER

GROUP	PUMP SIZE	H mm (inches)	WEIGHT Kg
HY3	22	70.8(2.787)	8.6
	27	74.6(2.937)	8.9
	33	79.2(3.118)	9.2
	39	83.8(3.299)	9.5
	44	87.6(3.448)	9.8
	48	100.6(3.960)	10.0
	52	103.7(4.087)	10.2
	61	110.6(4.354)	10.4

DIMENSIONS (side view)

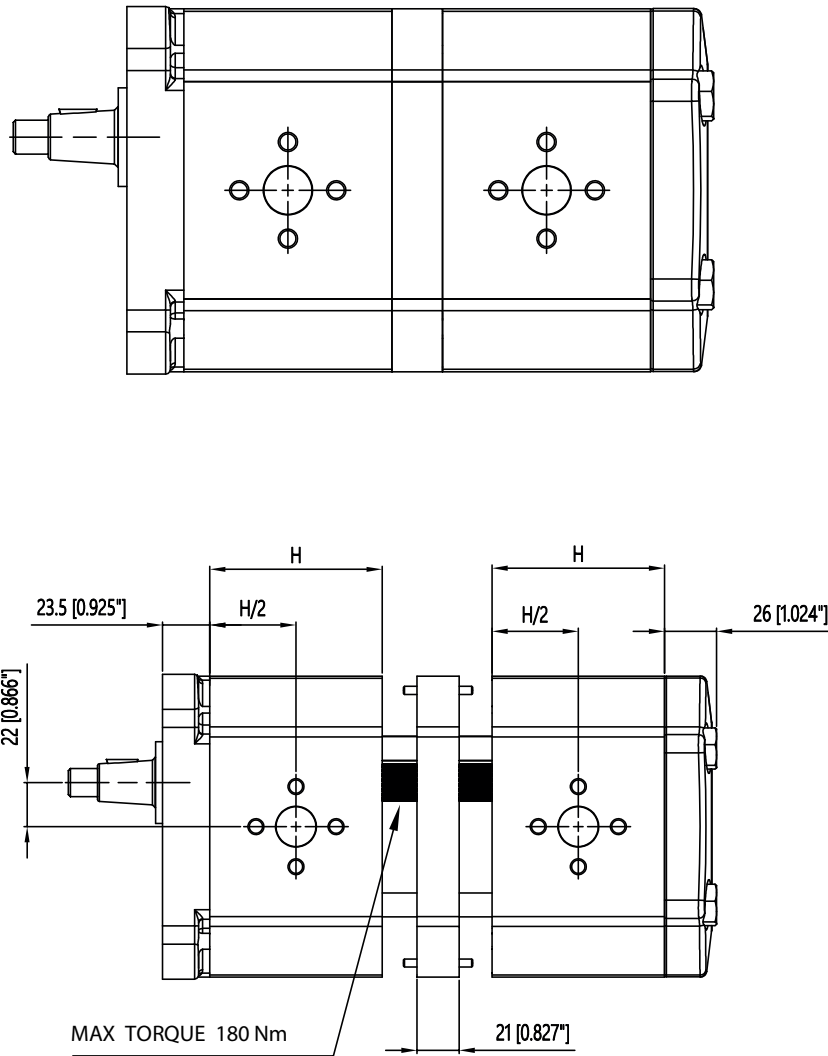

STANDARD CONFIGURATION
tandem pumps

GROUP	PUMP SIZE	H mm (inches)	WEIGHT Kg
HY3	22	70.8(2.787)	4.0
	27	74.6(2.937)	4.3
	33	79.2(3.118)	4.6
	39	83.8(3.299)	4.9
	44	87.6(3.448)	5.2
	48	100.6(3.960)	5.4
	52	103.7(4.087)	5.6
	61	110.6(4.354)	5.8

TANDEM PUMPS SCREW LENGTHS

SIZE cc Gr.3	22	27	33	39	44	48	52	61
22	200	210	245	215	220	235	235	245
27		210	245	220	225	240	240	250
33			220	225	230	240	245	250
39				230	230	245	250	255
44					240	250	255	260
48						265	265	275
52							270	275
61								285

Length expressed in millimeters

TANDEM PUMPS HY3+HY3
M12 screws size
10.9 screws class
Screws Tightening Torque = 100 +/- 5 Nm

EXAMPLES WITH COMMON INLET (top view)

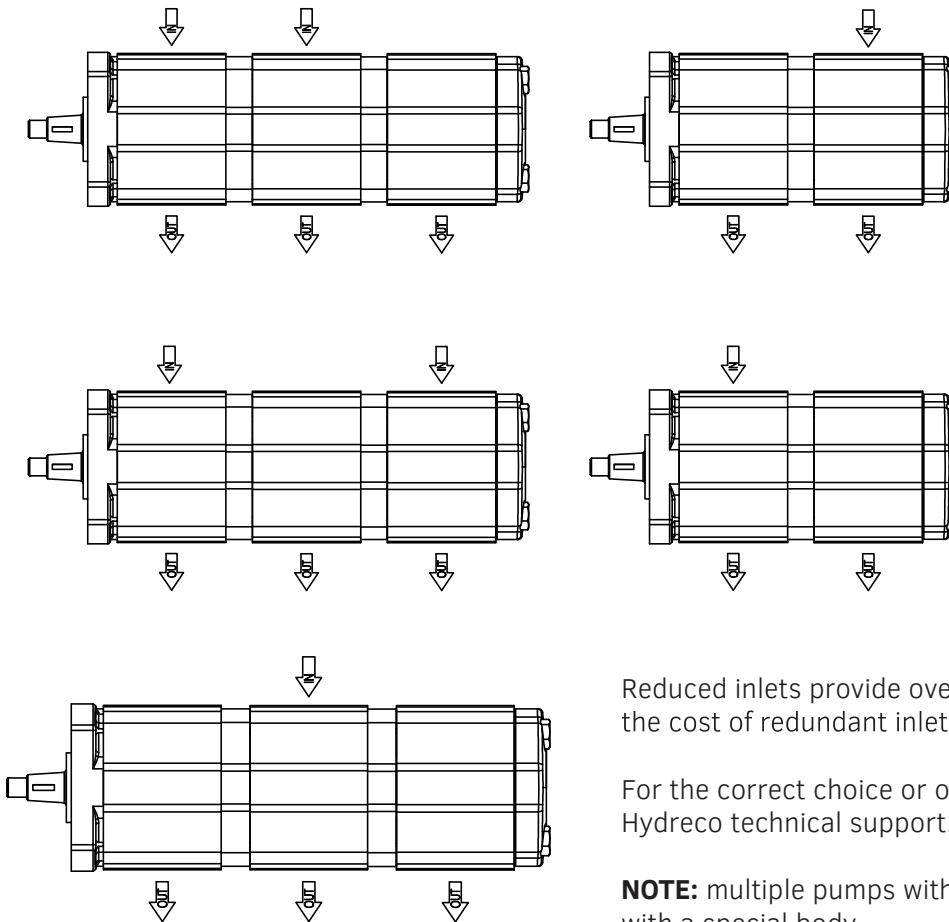

Reduced inlets provide overall systems savings by reducing the cost of redundant inlet hose and fittings.

For the correct choice or other combinations please contact Hydreco technical support.

NOTE: multiple pumps with common inlet will be provided with a special body

DIMENSIONS (side view)

The HY3 intermediate pumps include the intermediate flange & coupling to easily assemble tandem or multiple pumps.

GROUP	PUMP SIZE	H mm (inches)	WEIGHT Kg
HY3	22	70.8 (2.787)	4.0
	27	74.6 (2.937)	4.3
	33	79.2 (3.118)	4.6
	39	83.8 (3.299)	4.9
	44	87.6 (3.448)	5.2
	48	100.6 (3.960)	5.4
	52	103.7 (4.087)	5.6
	61	110.6 (4.354)	5.8

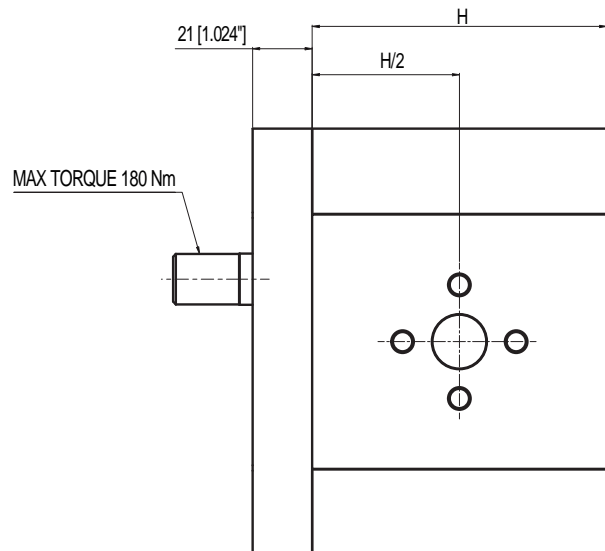

ORDERING CODE IDENTIFICATION FOR INTERMEDIATE PUMPS

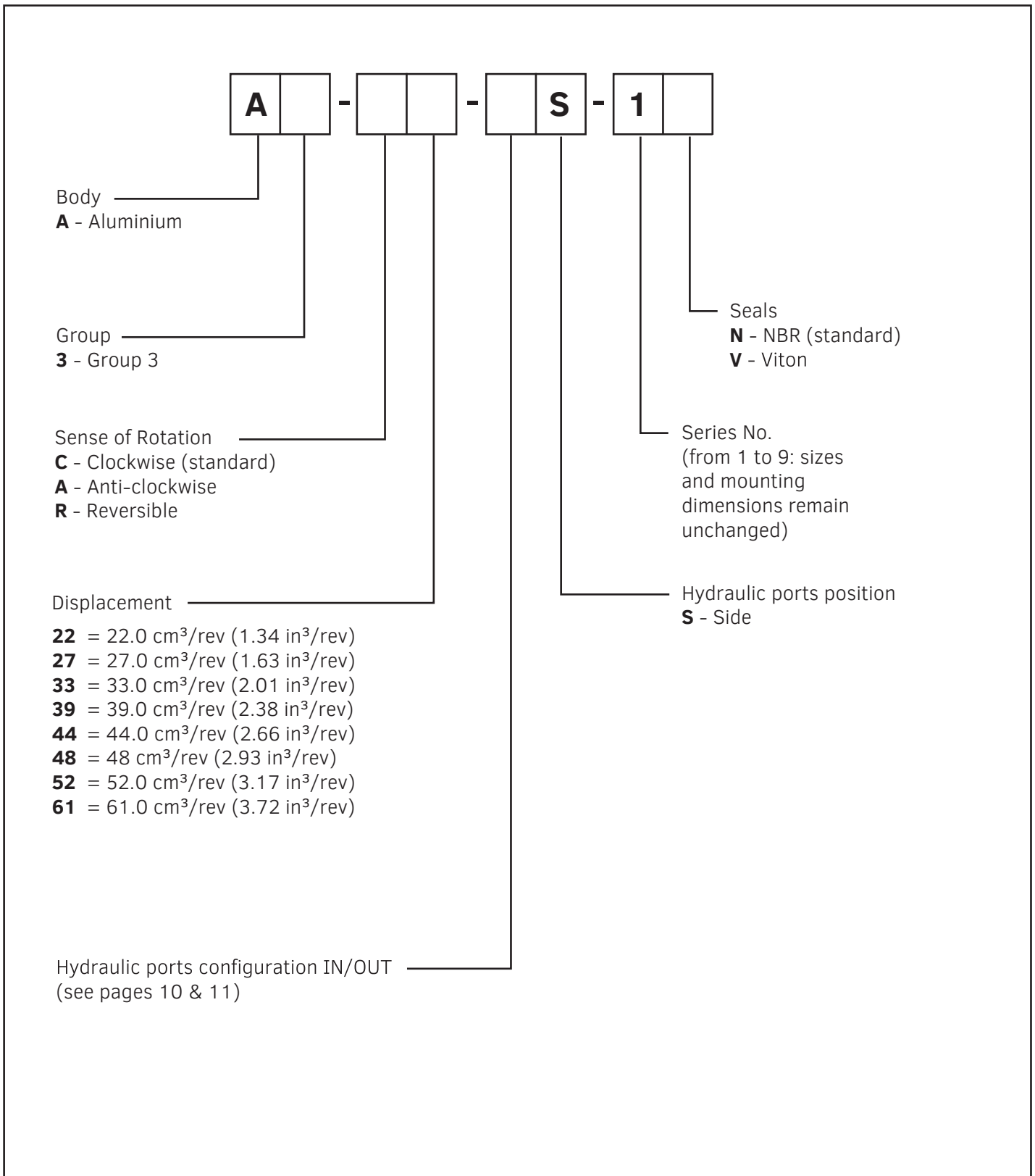

Example

A3-C22-FE4/3S-1N

GR3 intermediate pump - 22cc - european flanged ports

HOW TO MAKE TANDEM PUMPS USING AN INTERMEDIATE PUMP (side view)

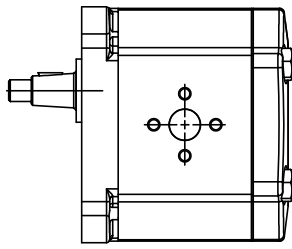

STANDARD PUMP

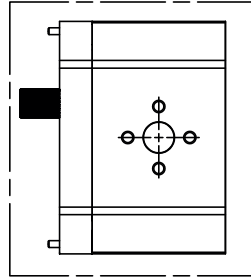

INTERMEDIATE PUMP

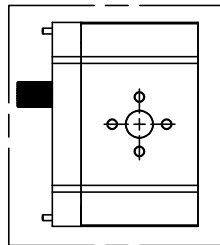
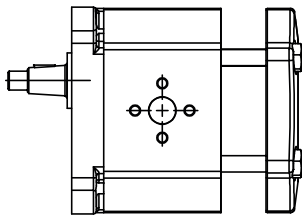

A. Loosen, and remove, the clamp screws and remove the cover.

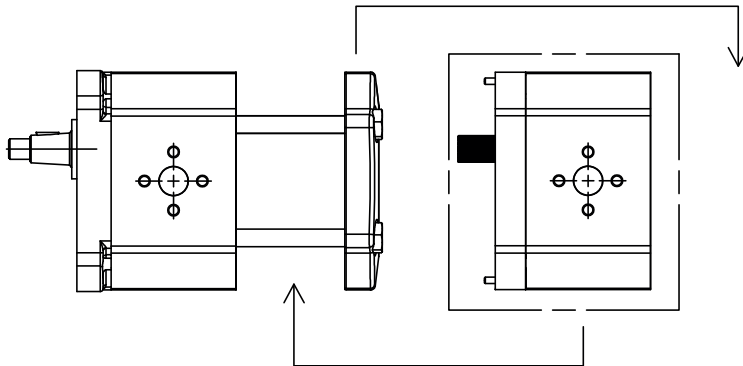

B. Connect the intermediate pump

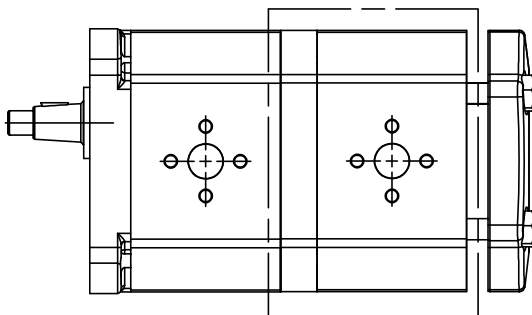

C. Assembling the tandem pump.
Refit the clamp screws.
SCREWS TIGHTENING TORQUE = $100 \pm 5 \text{Nm}$

DIMENSIONS (side view)

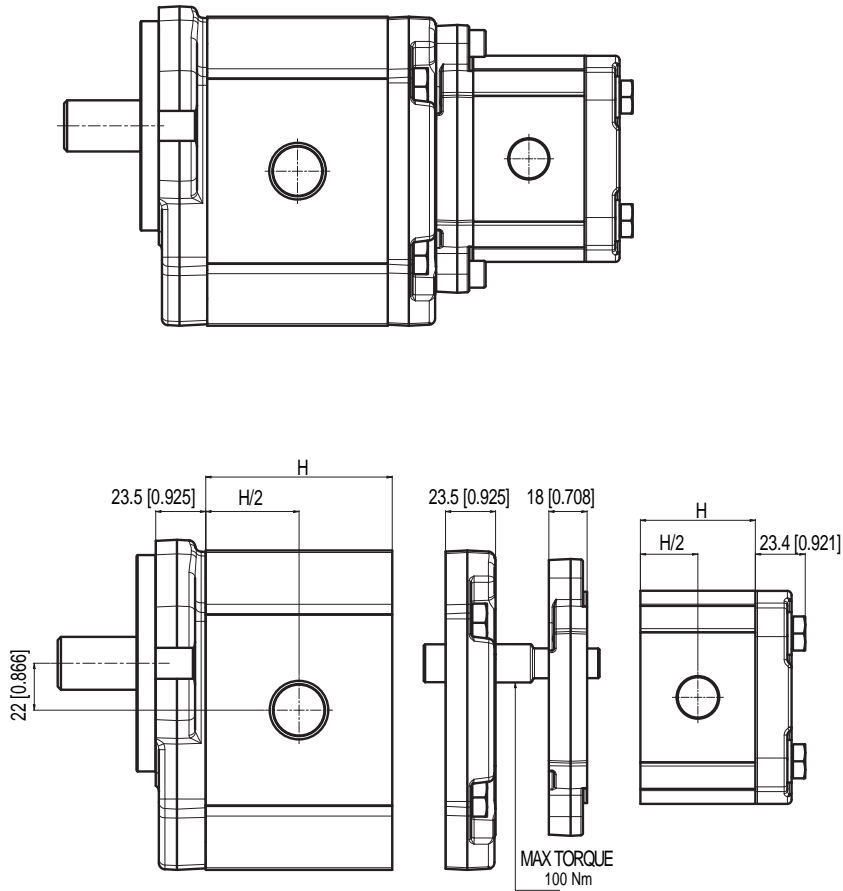

**STANDARD CONFIGURATION
tandem pumps**

GROUP	PUMP SIZE	H mm (inches)
HY3	22	70.8(2.787)
	27	74.6(2.937)
	33	79.2(3.118)
	39	83.8(3.299)
	44	87.6(3.448)
	48	100.6(3.960)
	52	103.7(4.087)
	61	110.6(4.354)

GROUP	PUMP / MOTOR SIZE	H mm (inches)
HY2	04	48.6 (1.913)
	06	51.5 (2.027)
	08	54.0 (2.125)
	11	58.4 (2.299)
	14	63.2 (2.488)
	16	66.6 (2.622)
	20	71.3 (2.807)
	22	82.0 (3.228)
	25	86.6 (3.409)
	28	91.0 (3.582)
	31	96.1 (3.783)

UNITS ROTATING CHANGING INSTRUCTIONS

- A. Clean the pump externally with care
- B. Coat the sharp edges of the drive shaft (2) with adhesive tape and smear a layer of clean grease on the shaft and extension to avoid damaging the lip of the shaft seal when removing the mounting flange
- C. Lay the pump on the working area in order to have the mounting flange turned upside.
- D. Loosen, and remove, the clamp screws (1).
- E. Remove the mounting flange (3), taking care to keep the flange as straight as possible during removal.
- F. Ensure that while removing the front mounting flange, the drive shaft and other components remain in position.
- G. Ease the drive gear (2) up to facilitate removal of bearings (4), taking care that the precision ground surfaces do not become damaged, and removed the drive gear
- H. Remove the driven gear (2) without overturning. The rear flange has not to be removed.
- I. Re-locate the driven gear in the position previously occupied by the drive gear (2).
- J. Re-locate the drive gear (2) in the position previously occupied by the driven gear (5).
- K. Re-locate the bushing (4) without rotating. Refit the front mounting flange (3) turned by 180°.
- L. Refit the clamp screws (1). **SCREW TIGHTENING TORQUE = 100±5Nm - M12**
- M. Check that the pump rotates freely when the drive shaft (2) is turned by hand.
- N. If not a pressure plate seal may be pinched.
- O. The pump is ready for installation with the new direction of rotation.

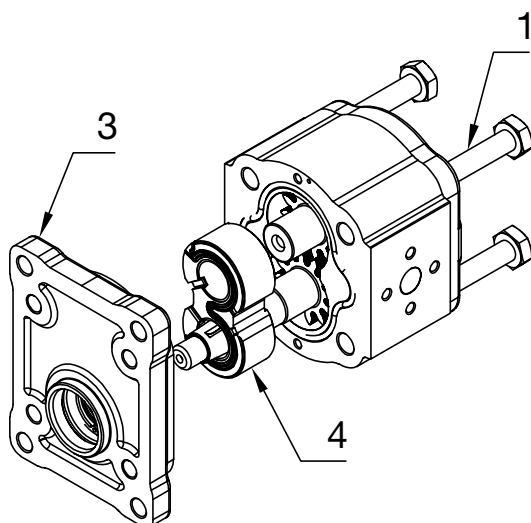
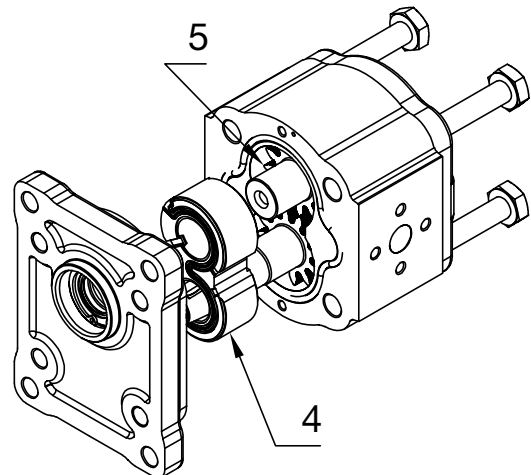
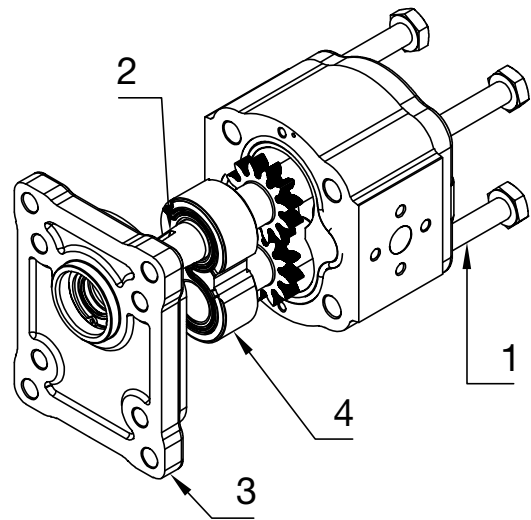

Supported by a worldwide network



CONTACT INFORMATION

EMEA

GERMANY	Hydreco Hydraulics GmbH, Straelen (NRW)	☎ +49 283494303-41	✉ info-de@hydreco.com
ITALY	Hydreco Hydraulics Italia Srl, Vignola (MO)	☎ +39 059 7700411	✉ sales-it@hydreco.com
ITALY	Hydreco Hydraulics Italia Srl, Parma (PR)	☎ +39 0521 1830520	✉ sales-it@hydreco.com
ITALY	Hydreco Srl, San Cesario S/P (MO)	☎ +39 059 330091	✉ cylinders@hydreco.com
NORWAY	Hydreco Hydraulics Norway AS, Nittedal	☎ +47 22909410	✉ post-no@hydreco.com
UK	Hydreco Hydraulics Ltd, Poole, Dorset	☎ +44 (0) 1202 627500	✉ info-uk@hydreco.com

AMERICAS

NORTH/LATIN	Hydreco Inc/ Continental Hydraulics Inc, Shakopee (MN)	☎ +1 952 895 6400	✉ sales@conthyd.com
--------------------	--	-------------------	---------------------

APAC

AUSTRALIA	Hydreco Hydraulics Pty Ltd, Seven Hills (NSW)	☎ +61 2 9838 6800	✉ sales-au@hydreco.com
AUSTRALIA	Hydreco Hydraulics Pty Ltd, Welshpool (WA)	☎ +61 8 9377 2211	✉ reception-wa@hydreco.com
INDIA	Hydreco Hydraulics India Private Ltd, Bangalore	☎ +91 80 67656300	✉ sales-in@hydreco.com

