

IPA100 - Pressure reducing valve

Spool, pilot operated
 100 L/min (26 USgpm) • 10 bar (150 psi) to 350 bar (5000 psi)

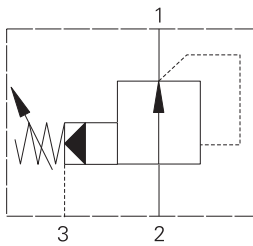

Operation

This valve is normally open, allowing oil from the inlet to pass through to the regulated port of the cartridge.

When the regulated pressure reaches the valve setting, the pilot section opens causing a pressure imbalance across the main spool which moves, throttling the inlet flow, preventing any further pressure rise in the regulated line.

Features

Internal parts hardened, match ground and honed to give long, trouble-free life. Pilot style design allows for high flows and accurate performance.

Sectional view

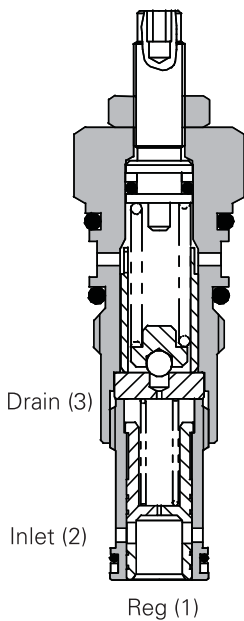

Performance data

Ratings and specifications

Figures based on: Oil Temp = 40° C Viscosity = 32 cSt (150 SUS)

Rated flow	100 L/min (26 USgpm)	
Pressure range	10 to 350 bar (150 to 5000 psi)	
Max differential	210 bar (3000 psi) between 1 and 2	
Cartridge material	Working parts hardened and ground steel. External surfaces zinc plated.	
Body material	Standard aluminium (up to 210 bar*). Add suffix "377" for steel option.	
Mounting position	Unrestricted	
Cavity number	A880 (See Section M)	
Torque cartridge into cavity	60 Nm (44 lbs ft)	
Weight	1PA100	0.17 kg (0.37 lbs)
	1PA150	0.60 kg (1.32 lbs)
Seal kit number	SK177 (Nitrile) SK177V (Viton®)	
Recommended filtration level	BS5540/4 Class 18/13 (25 micron nominal)	
Operating temp	-30°C to +90°C (-22°C to 194°F)	
Pilot flow	500 milliliters/min @ standard setting	
Nominal viscosity range	5 to 500 cSt	

Viton is a registered trademark of E.I. DuPont

Description

This is a pilot operated pressure reducing valve designed to maintain a constant downstream pressure lower than the inlet pressure. Ideal for use in two pressure systems or to protect low pressure actuators such as brake cylinders.

Pressure drop curve

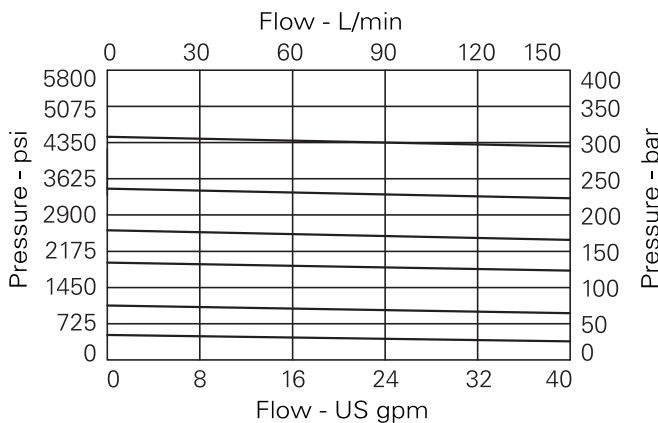

Where measurements are critical request certified drawings. We reserve the right to change specifications without notice.

1PA100 - Pressure reducing valve

Spool, pilot operated
100 L/min (26 USgpm) • 10 bar (150 psi) to 350 bar (5000 psi)

Model code

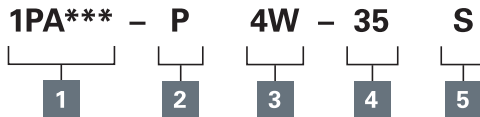

1 Basic code

1PA100 - Cartridge Only
1PA150 - Cartridge and Body

2 Adjustment means

P - Leakproof Screw Adjustment
R - Handknob Adjustment
G - Tamperproof Cap (See page E-7 for dimensions)

3 Port sizes - bodied valves only

Code	Port size	Housing number	
		Aluminium single	Steel single
4W	1/2" BSP. 1/4" BSP Drain Port	B4821	B4527
6W	3/4" BSP. 1/4" BSP Drain Port	B5466	B4403
8T	1/2" SAE. 1/4" SAE Drain Port	B6584	
12T	3/4" SAE. 1/4" SAE Drain Port	B7883	B11379

4 Pressure range @ zero flow

Note: Code based on pressure in bar.

7 - 10–70 bar
Std setting 20 bar
20 - 15–210 bar
Std setting 100 bar
35 - 30–350 bar
Std setting 280 bar
Std setting made at zero flow (dead head)

5 Seals

S - Nitrile (For use with most industrial hydraulic oils)
SV - Viton® (For high temperature and most special fluid applications)

Dimensions

mm (inch)

Cartridge only

Basic Code
1PA100

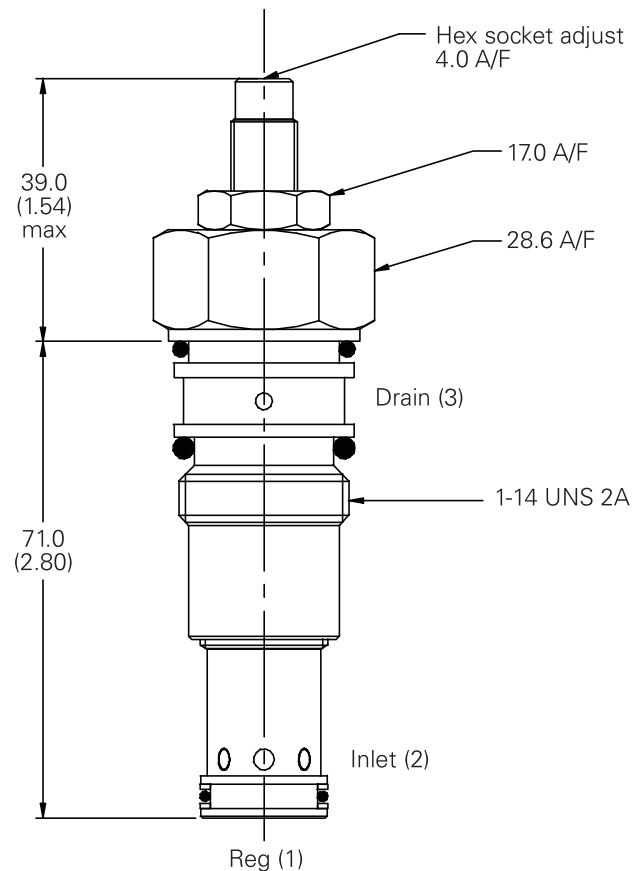

Complete valve

1/2"; 3/4" Ports
Basic Code
1PA150

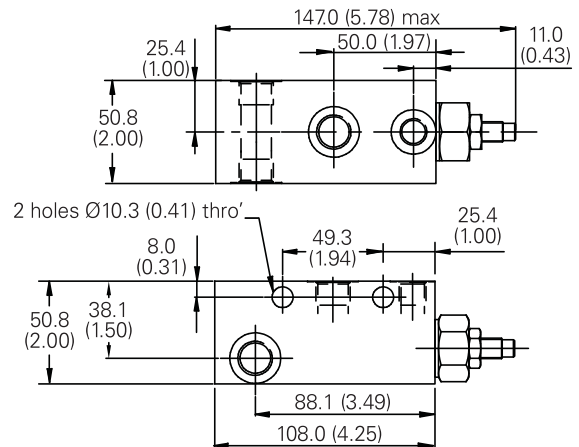

Note: Tightening torque of "F" adjuster locknut - 20 to 25 Nm

Note: For applications above 210 please consult our technical department or use the steel body option.

Where measurements are critical request certified drawings. We reserve the right to change specifications without notice.