

Data Sheet

PLUS+1[®] Controllers

MC038-010 and MC038-012



Mobile machine management

Danfoss PLUS+1[®] controllers are elements of the flexible, powerful, expandable, and affordable family of mobile machine management products. These devices are general-purpose controllers that are equally suited for use as a member of a distributed machine control system, with intelligence in every node, or as a stand-alone controller.



Product highlights

Both controllers employ a Digital Signal Processor (DSP), providing the controller with extremely fast single cycle processing speed and 128K internal flash.

Application development

The MC038-012 employs an application key that enables the use of Danfoss developed PLUS+1[®] GUIDE machine control solutions. The same PLUS+1[®] GUIDE HWD file is used with both controllers.

Users develop MC038-010 and MC038-012 applications with PLUS+1[®] GUIDE. This Microsoft Windows based development environment features a user-friendly, field proven, icon-based graphical programming tool, application downloader, and service/diagnostic tool.

Features

- User-programmable with PLUS+1[®] GUIDE
- Support of unlimited read-write FRAM, 2MB flash vault memory
- 38 pins: (1) DEUTSCH DRC connector
- 32 bit fixed-point DSP running at 150 MHz
- 12 bit analog-to-digital converter
- 15 inputs
- 13 outputs
- 9 to 36 V_{DC} power supply, monitored internally
- 2 CAN 2.0 B ports, the fixed range analog input can be configured as the shield pin
- 1 independent ECU power supply, 6 V_{DC} to 36 V_{DC}, and regulated internally
- 3 independent power supplies for powering output pins, 9 to 36 V_{DC}
- 1 CAN 2.0B port. The fixed range analog (AIN/CAN Shield) pin may be configured as a shield pin
- 5 V_{DC} power supply for external sensors rated at 150 mA, monitored and regulated internally
- 2 LEDs under application software control
- CE compliant

15 Inputs

- (3 universal (DIN/AIN/FreqIN) that are user-defined as either:
 - *Analog*: with configurable ranges 0 to 5.25 V_{DC} (with over range protection) or 0 to 36 V_{DC}
 - *Digital*: pull up (5 V_{DC}), pull down (0 V_{DC}) or pull to center (2.5 V_{DC})
 - *Frequency* (timing): 1 Hz to 10 kHz
- (2) digital (DIN) configurable as pull up (5 V_{DC}), pull down (0 V_{DC})
- (9) digital/analog (DIN/AIN) that are user-defined as either:
 - *Digital*: pull up (5 V_{DC}), pull down (0 V_{DC}) or pull to center (2.5 V_{DC})
 - *Analog*: 0 to 5.25 V_{DC} or 0 to 36 V_{DC}
- (1) fixed range analog (AIN/CAN shield) 0 to 5.25 V_{DC} or CAN shield pin

13 Outputs

- (2) DOUT (2 A) configurable as source only
- (3) HDOUT (6 A) configurable as source only
- (3) HPWMOUT/DOUT (6 A), configurable as source only
- (4) HPWMOUT/DOUT (10 A) configurable as source only, can be used as bi-directional pairs, (see Dimensions and Pin Assignments, back page for pair assignments)
- (1) HPWMOUT/DOUT (10A) configurable as source only
- Outputs are powered by three independent power supply pins (see Dimensions and Pin Assignments, back page for output pin power supply assignments and maximum allowable current per power supply pin)
- All PWM outputs operate as open loop. The output is a constant voltage.

Comprehensive technical literature is online at www.danfoss.com

Characteristics

Specifications

Supply voltage	9 to 36 V _{DC}
Operating temperature (ambient)	–40 °C to +70 °C [–40 °F to +158 °F]
Storage temperature	–40 °C to +85 °C [–40 °F to +185 °F]
Programming temperature	0 °C to +70 °C [+32 °F to +158 °F]
IP rating (with mating connector attached)	IP 67
EMI/RFI rating	100 V/M
Weight	0.53 kg [1.16 lb]
Vibration	IEC 60068-2-64
Shock	IEC 60068-2-27 test Ea
Max. current, sourcing	70 A
Max. current, sinking	25 A
Max. current, power pins: C1-P36, C1-P37, C1-P38	25 A per pin

Dimensions and pin assignments

Mounting dimensions in mm

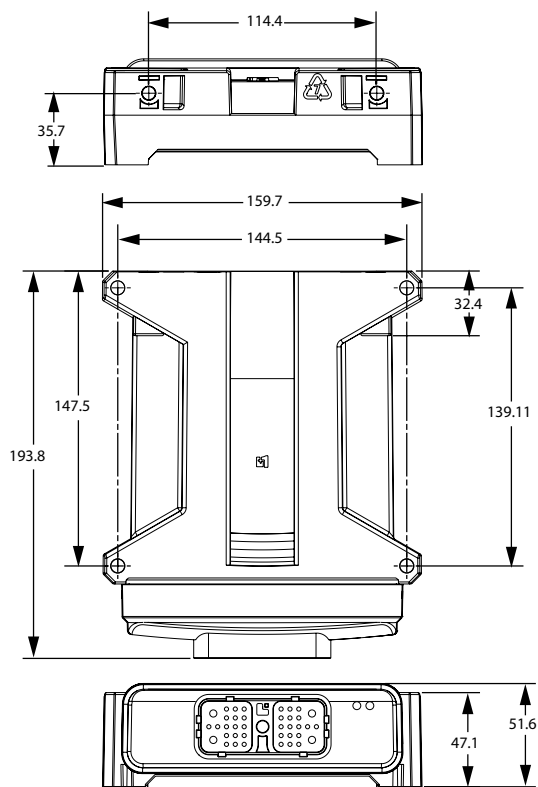

Pin connector

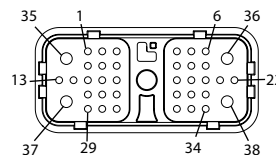

Pin	Function	Pin	Function
C1-P1	CPU power ground -	C1-P20	DIN/AIN
C1-P2	CPU power supply +	C1-P21	HPWM/DOUT (6A-Pwr = C1-P37, source only)
C1-P3	CAN0 +	C1-P22	HPWM/DOUT (10A-Pwr = C1-P37, source only)
C1-P4	CAN0 -	C1-P23	DOUT (2A-Pwr = C1-P38, source only)
C1-P5	AIN/CAN shield	C1-P24	DIN/AIN
C1-P6	DIN	C1-P25	DIN/AIN
C1-P7	DIN	C1-P26	DIN/AIN
C1-P8	5 V _{DC} sensor power +	C1-P27	DIN/AIN
C1-P9	Sensor power ground -	C1-P28	DOUT (2A-Pwr = C1-P38, source only)
C1-P10	DIN/AIN/FreqIN	C1-P29	DOUT (2A-Pwr = C1-P38, source only)
C1-P11	DIN/AIN/FreqIN	C1-P30	DOUT (6A-Pwr = C1-P38, source only)
C1-P12	DIN/AIN/FreqIN	C1-P31	DOUT (6A-Pwr = C1-P38, source only)
C1-P13	HPWM/DOUT (10A-Pwr = C1P37, pair with C1-P15)	C1-P32	DOUT (6A-Pwr = C1-P38, source only)
C1-P14	DIN/AIN	C1-P33	HPWM/DOUT (6A-Pwr = C1-P36, source only)
C1-P15	HPWM/DOUT (10A-Pwr = C1P37, pair with C1-P13)	C1-P34	HPWM/DOUT (10A-Pwr = C1-P36, pair with C1-P29)
C1-P16	HDOUT (6A-Pwr = C1-P38, source only)	C1-P35	Output power ground -
C1-P17	DIN/AIN	C1-P36	Output power supply +
C1-P18	DIN/AIN	C1-P37	Output power supply +
C1-P19	DIN/AIN	C1-P38	Output power supply +

! Caution

PCB damage may occur.

To prevent damage to the module all module power supply + pins must be connected to the vehicle power supply to support advertised module maximum output current capacity. **DO NOT** use module power supply + pins to supply power to other modules on a machine.

! Caution

Warranty will be voided if device is opened.

Device is not field serviceable. Do not open the device.

Use care when wiring mating connector. Pinouts are for device pins.



Product part number

MC038-010	11035917
MC038-012	11076594

Related products part numbers

CG150 CAN/USB Gateway	11153051
DEUTSCH mating connector bag assembly	11027919 (16 to 20 AWG)
PLUS+1[®] GUIDE Professional	11179523

Comprehensive information

<i>MC0XX-0XX Controller Family Technical Information, 520L0719</i>
<i>MC038-010 and MC038-012 Application Program Interface (API) document</i>

Danfoss can accept no responsibility for possible errors in catalogues, brochures and other printed material. Danfoss reserves the right to alter its products without notice. This also applies to products already on order provided that such alterations can be made without changes being necessary in specifications already agreed.
All trademarks in this material are property of the respective companies. Danfoss and the Danfoss logotype are trademarks of Danfoss A/S. All rights reserved.
