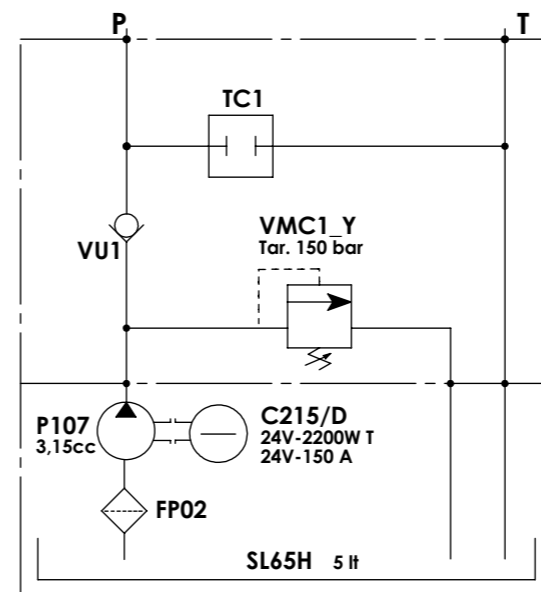

Table of materials			
Num. article	Part. num	DENOMINAZIONE_ENG	Quantity
1	S515G05KEL07	Central manifold KEL7 - 12,7; A1A	1
2	EC035M08	Plug expander Ø8	1
3	F732005	Check valve VU1	1
4	F733006250	Relief valve VMC1 250 bar	1
5	F749000	TC1-Plug 3/4-16UNF, Ø12.7	1
6	EC10913.15045	Pump gr1 - 1,60cc - S - 302 SX	1
7	ES52435355	Plastic suction pipe 90° 1/4" Y=77	1
8	ES5063500001	Plastic suction filter 3/8" BSP	1
9	ES52301109	SD170-Return steel pipe M12x1 L170	1
10	ES52301003	Return pipe ir. M12x1 L164 H84	1
11	EC114268	O-Ring NBR 70Sh. 110.72x3.53 - 4437	1
12	ES51120050A	Steel tank Ø200 lt 5 SL65	1
13	EC1270212160	Filler cap sf + filter TMDFA-1/2" L=160	1
14	EC031003C	Short steel plug with OR, 1/2"	1
15	ES5085320017	Junction element FC02 160-220	1
16	EC106215	DC motor 24V-2200W T (C215)	1
17	EC108012	Starting raly 24V-150A TR	1
18	ES177003	Copper motor-relay plate	1
19	EC12601ST12	Plastic protection plug 1/4"	2



P-T=G1/4"

MATERIALE		PESO (Gr.)	
Materiale <non specificato>		3346.44	
COLORE		N° STAMPO	
TRATTAMENTO TERMICO E/O SUPERFICIALE			
RUGOSITA' (Ra)		R/ NON QUOTATI	
SM/ NON QUOTATI			
00	EMISSIONE	19/02/2018	D.Saccani
IND.	MODIFICA	DATA	NOME
DATA	DISEGNATO	CONTROLLATO	APPROVATO
19/02/2018	D.Saccani	D.Saccani	D.Saccani
FIRMA	VERIF. NORME	QUOTE SENZA INDIC. DI TOLLERANZA	
D.Saccani	D.Saccani	SCALA	
TECFLUID S.r.l.		1:4	
Via Ragazzi del '99, 38		DENOMINAZIONE	
42124 Mancasale - Reggio Emilia - ITALY		031_A1AY/TC1/P107/SL65H/C215/D/FC02/1H/G00	
Tel. 0522 / 926369 - Fax. 0522 / 922440		GRUPPO	
N° CODICE P1A1072045		REV. 00	
FOGLIO Esploso cliente			

A TERMINI DI LEGGE CI RISERVIAMO LA PROPRIETA' DI QUESTO DISEGNO CON DIVIETO DI RIPRODUZIONE E DI DIFFUSIONE A TERZI SENZA NOSTRA AUTORIZZAZIONE SCRITTA

N°2 Fixing holes M10

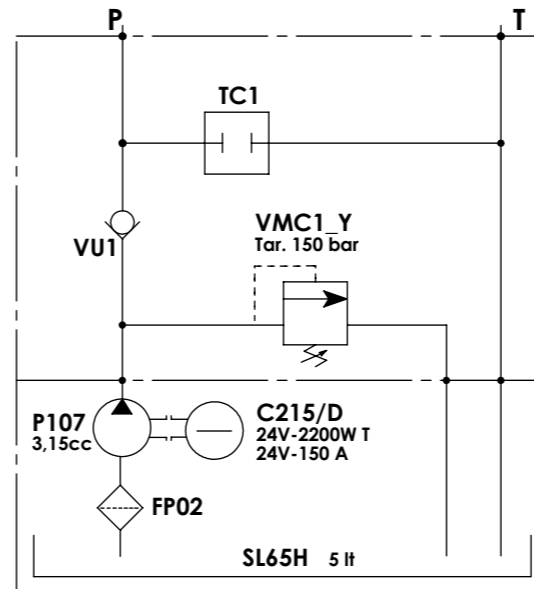
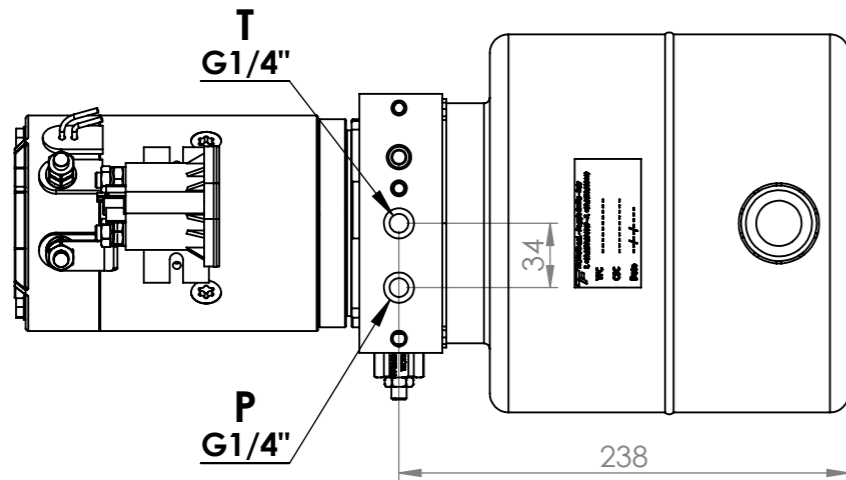
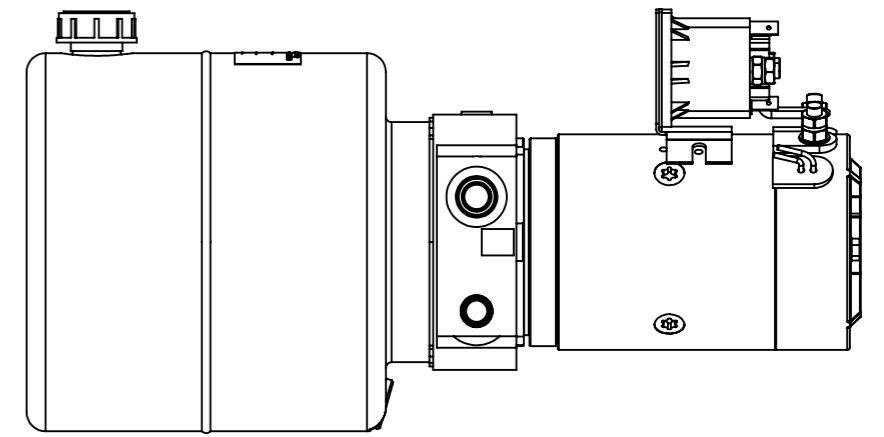
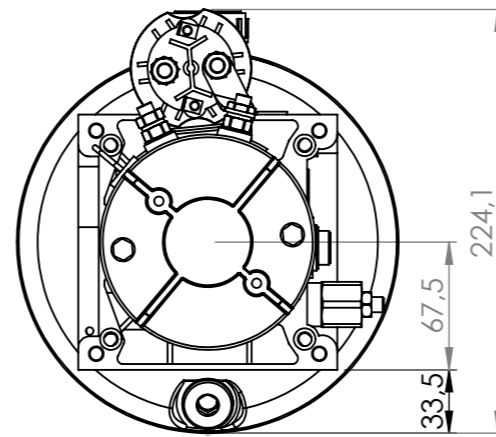
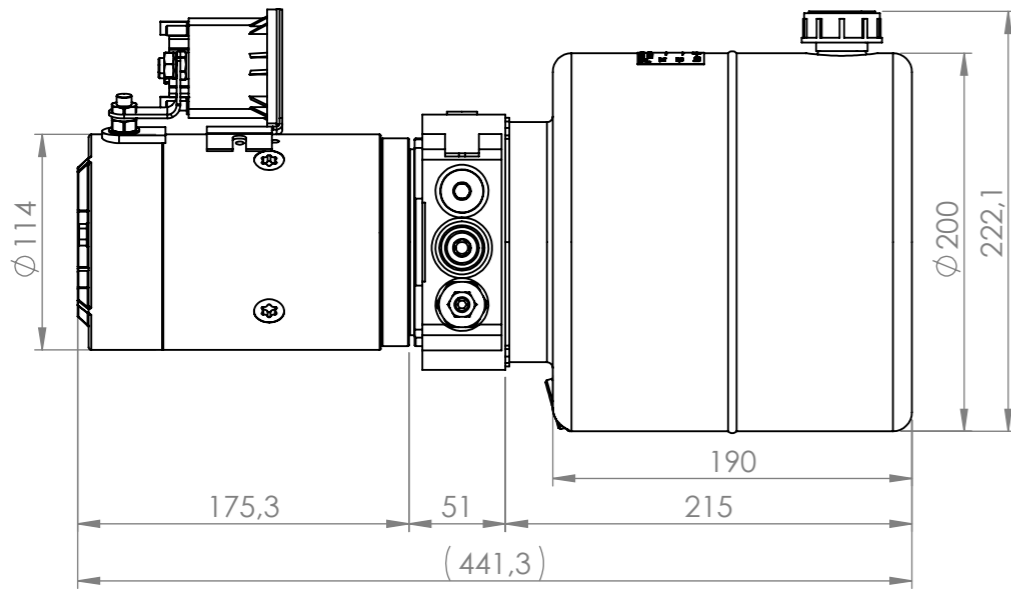
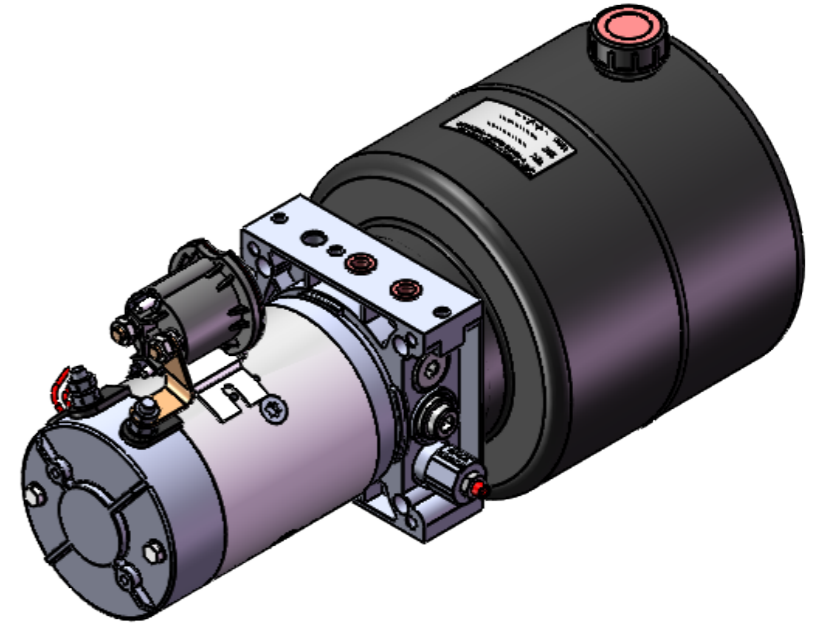
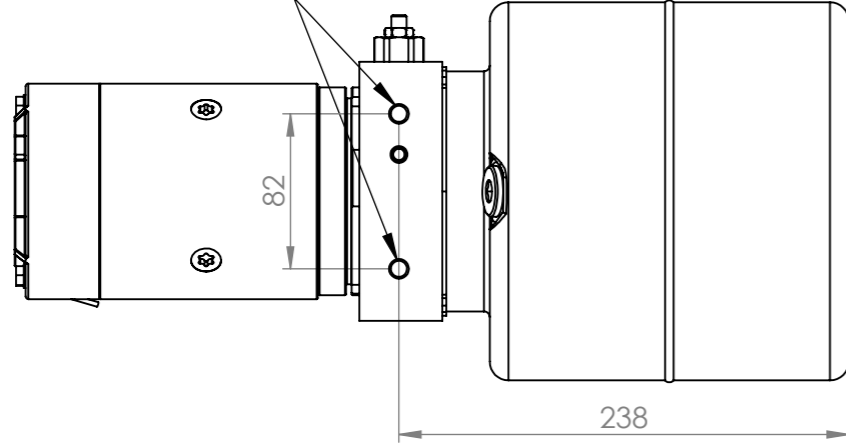

P-T=G1/4"

				MATERIALE		PESO (Gr.)	
				Materiale <non specificato>		3346.44	
				COLORE		N° STAMPA	
				TRATTAMENTO TERMICO E/O SUPERFICIALE			
				RUGOSITA' (Ra)		R/NON QUOTATI	
				SM/NON QUOTATI			
00	EMISSIONE			19/02/2018	D.Saccani	SOSTITUISCE IL	DATA
						DATA	NOME
IND.	MODIFICA			DATA	NOME	SOSTITUITO DA	DATA
	DISEGNATO	CONTROLLATO	APPROVATO	VERIF. NORME	QUOTE SENZA INDIC. DI TOLLERANZA		SCALA
DATA	19/02/2018	19/02/2018	19/02/2018				1:4
FIRMA	D.Saccani	D.Saccani	D.Saccani				
GRUPPO		N° CODICE		REV.		FOGLIO	
TECFLUID S.r.l.		P1A1072045		00		Ingombri	
Via Ragazzi del '99, 38							
42124 Mancasale - Reggio Emilia - ITALY							
Tel. 0522 / 926369 - Fax. 0522 / 922440							
A TERMINI DI LEGGE CI RISERVIAMO LA PROPRIETA' DI QUESTO DISEGNO CON DIVIETO DI RIPRODUZIONE E DI DIFFUSIONE A TERZI SENZA NOSTRA AUTORIZZAZIONE SCRITTA							