

Low Pressure Compensator Line

SAE 1" to 5"



Rubber compensators are elastic connectors with turnable SAE flanges. Compensators are used for damping oscillations, vibrations, noises and movements in axial and transversal direction. The installation can be adapted with butterfly valves and weld-on flanges to form a complete suction unit.

Design

Rubber compensators have a plain surface vulcanized to a fabric body (inside and outside) of the rubber part. The outside is weather resistant and protects the fabric against ageing, wear and corrosion. The interior of the rubber part consists of nitril-butadien-caoutchouc (NBR). The outer layer is a mixture of Chloroprene/Naturalrubber (CR/NR). Because compensators have tightening lips on both sides, further seals are not necessary.

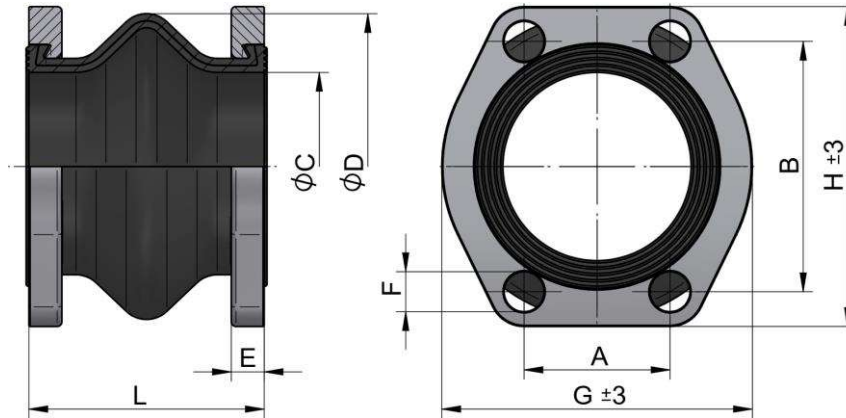

Technical Data

order number	description	size		A	B	C	D	E	F	G	H	L	weight
		SAE	NG*										
SDKSS025	K16S – 25	1"	25	26,2	52,4	25 ⁺¹ ₋₃	53±2	11	11	59	70	65±3	0,4
SDKSS032	K16S – 32	1 ¼"	32	30,2	58,7	32 ⁺¹ ₋₃	60±2	11	13	73	79	65±3	0,5
SDKSS040	K16S – 40	1 ½"	40	35,7	70,0	40 ⁺¹ ₋₃	80±2	13	13	83	94	100±4	0,8
SDKSS050	K16S – 50	2"	50	42,9	77,8	48 ⁺¹ ₋₃	96±2	13	13	97	102	100±4	1,0
SDKSS063	K16S – 63	2 ½"	63	50,8	89,0	63 ⁺¹ ₋₃	111±3	14	13	109	114	100±4	1,2
SDKSS080	K16S – 80	3"	80	62,0	106,4	80 ⁺¹ ₋₃	130±3	14	17	132	136	100±4	1,8
SDKSS090	K16S – 90	3 ½"	80	70,0	120,7	80 ⁺¹ ₋₃	130±3	14	17	140	152	100±4	2,4
SDKSS092	K16S – 92	3 ½"	90	70,0	120,7	90 ⁺¹ ₋₃	140±3	14	17	140	152	100±4	1,9
SDKSS100	K16S – 100	4"	100	77,8	130,2	100 ⁺¹ ₋₃	150±3	16	17	152	162	100±4	2,5
SDKSS126	K16S – 125	5"	125	92,0	152,4	125 ⁺¹ ₋₃	180±3	16	17	165	184	130±4	3,0

*... NG = nominal size

This data sheet and the corresponding scale drawings are to be used as a general guideline and technical overview of our products. Please contact us if more exact information is needed. As we are constantly improving our products, their characteristics, dimensions and weights may also change, although we do our best to incorporate these changes continually. asa assumes no liability for any information therein, any errors, omissions, misprints, nor any direct or indirect damages, losses or costs resulting therefrom. Any cooling performances and general technical values indicated in this catalogue are measured at a test bench according to asa testing procedures or calculated, based on such tests. They represent a basis for your product selection. Due to different conditions in testing and application environments the performance may also vary by +/- 15%. All sound values are determined in accordance with ISO 9614-2, DIN EN ISO 11203 accuracy class 3 or Machinery Directive 2006/42/EG and are A-rated. At some of the performance data, possible differences to competition data are possible. The reason to that are no existing standardized testing procedures on individual subjects, e.g. for cooling performance measurements. Therefore, we recommend all products to be checked under the system operating conditions. This is also true of vibrations and mechanical stress as well as for pressure peaks and thermal stress and any other relevant factors. General tolerances according to DIN ISO 2768-M. General tolerances for casted parts according EN ISO 8062-3 (DCTG 10). Tolerances for rubber parts are according to ISO 3302-1 (class M4-F+C). The tolerances of welding seams are defined by quality group D according to EN ISO 10042, if it is not specified on the actual scale drawing or data sheet. Any form of liability is excluded for the information included in this datasheet. All details and calculation values are checked to the best of our ability, but these do not ensure any intrinsic product properties; due to the wide-ranging possible applications, it is advised that all technical data herewith included be confirmed through testing carried out by the end-user. asa technology Produktions- und Vertriebs GmbH reserves the right to modify the product without any separate notification. This refers to both technical data and the product itself. Furthermore, it is herewith specified that the datasheet does not substitute the corresponding scale drawings, assembly and installation guidelines, nor the operating instructions.

DC-SDKSSxxx-en-rev9 © asa technology, August 2024 page 1/1

Low Pressure Compensator Line

SAE 1" to 5"



Movements Limits

Please read our manual before installation!

order number	description	axial**		lateral**	angular**
		min. [mm]	max. [mm]		
SDKSS025	K16S – 25	62,5	67,5	2,5	3,5
SDKSS032	K16S – 32	62,5	67,5	2,5	3,5
SDKSS040	K16S – 40	95	105	5	5
SDKSS050	K16S – 50	95	105	5	5
SDKSS063	K16S – 63	95	105	5	5
SDKSS080	K16S – 80	95	105	5	5
SDKSS090	K16S – 90	95	105	5	5
SDKSS092	K16S – 92	95	105	5	5
SDKSS100	K16S – 100	95	105	5	5
SDKSS126	K16S – 125	125	135	5	5

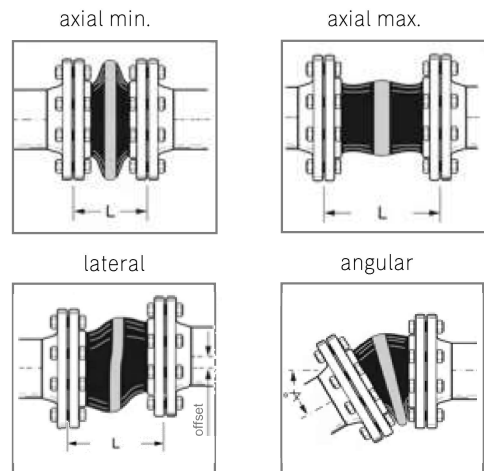

**...Allowable static movement range up to 60°C. Above 60°C, the static movement range will be reduced by 50%. Please note: Data not valid for combined movements. Please contact us for assistance.

Material

rubber inside	NBR
rubber outside	CR/NR (Chloroprene/Naturalrubber)
rubber hardness	70 shore ±5
flange	steel

Compatibility

Standardized mineral oil products (except synthetic oils), crude oil, lubrication oil, cooling oil (-20°C up to 80°C), grease (mineral), cold water, warm water up to 80°C, water/oil emulsions.

Working Range

maximum working pressure	NG25 to NG80 0,5 - 1,5bar (absolute) NG90 to NG125 0,7 - 1,5bar (absolute)
temperature range, depending on fluid, movement and pressure	-20°C bis +80°C



Please read manual before installation and for the maximum movement tolerances of the rubber connection! Note, that the dimension tolerances have to be taken from the corresponding scale drawing.