

SPC2-8 - Check Valve

Pilot-to-open, poppet type

19 L/min (5 USgpm) • 240 bar (3500 psi)

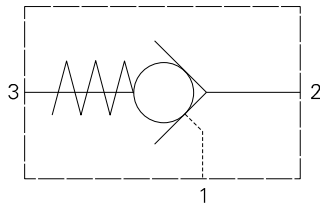

Operation

Pressure on the valve port 2 causes the poppet to lift against the spring force, allowing the flow to the cylinder port 3. Reverse flow is prevented by the poppet reseating.

Pressure applied to the pilot port 1 will overcome the cylinder port pressure and lift the poppet from its seat, allowing flow from the cylinder to valve port.

Features

Hardened and ground poppet gives excellent flow capability for valve size, positive sealing and long working life. Cartridge construction allows installation in actuators, manifold blocks and Hydraulic Integrated Circuits. Fits the same cavity as the overcenter valves of a similar size.

Sectional View

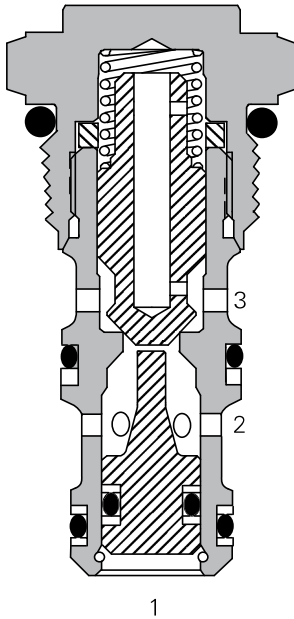

Performance Data

Ratings and Specifications

Performance data is typical with fluid at 21,8 cSt (105 SUS) and 49°C (120°F)

Typical application pressure (all ports)	240 bar (3500 psi)
Cartridge fatigue pressure (infinite life)	240 bar (3500 psi)
Rated flow	19 L/min (5 USgpm)
Pilot ratio	3:1
Cracking pressure	15 - 1,0 bar (15 psi) 35 - 2,4 bar (35 psi) 65 - 4,5 bar (65 psi)

Internal leakage (all leak rates @ 240 bar (3500 psi))	5 drops/min. maximum at 240 bar (3500 psi)
Port 3 to 2	140 cc/min. maximum, zero leakage with sealed piston
Port 2 to 1 unsealed piston*	

*Unsealed piston only supplied with 15 psi spring option

Temperature range	-40° to 120°C (-40° to 248°F)
Cavity	C-8-3
Fluids	All general purpose hydraulic fluids such as MIL - H-5606, SAE 10, SAE 20, etc
Recommended filtration	Cleanliness code 18/16/13
Standard housing materials	Aluminum or steel
Weight, cartridge only	0,07 kg (0.15 lbs.)
Seal kit	02-173326 (Buna-N) 02-173327 (Viton®)

Viton is a registered trademark of E.I. DuPont

Description

Pilot check valves allow flow to pass in one direction, with a low pressure drop, then prevent reverse flow until pilot pressure is applied. There are many applications for this valve type, the most common being to lock and hold a cylinder, or another hydraulic actuator, in position.

These valves are ideally suited for fitting directly into a cylinder, giving economy of installation, direct control of cylinder movement and ease of servicing.

Pressure Drop

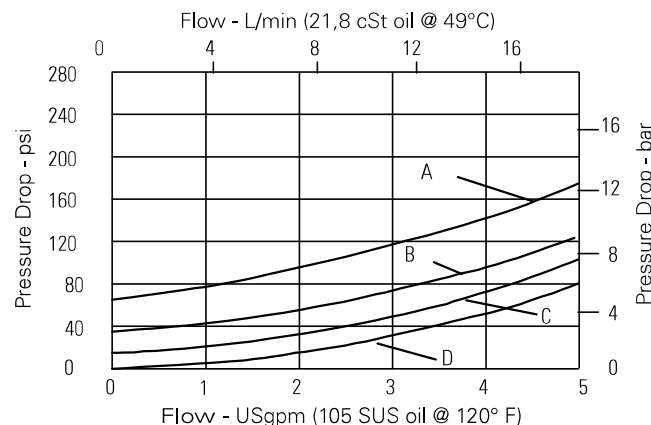

A - CV6 16*P 0000 050 00
B - CV6 16*P 0000 020 00

C - CV6 16*P 0000 005 00

Where measurements are critical request certified drawings. We reserve the right to change specifications without notice.

SPC2-8 - Check Valve

Pilot-to-open, poppet type
19 L/min (5 USgpm) • 240 bar (3500 psi)

Model Code

SPC2 - 8 (X) - P - (*) ** - ** - 00

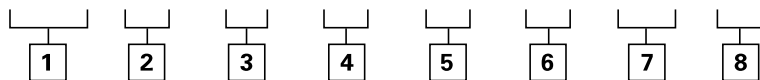

1 Basic Code
SPC2 - Single pilot check valve

2 Size
8 - 8 size

3 Seals
Blank - Buna-N
V - Viton
U - Buna-N with no piston seals
W - Viton with no piston seals

4 Style
P - Poppet

5 Valve Body Material
Omit for cartridge only
A - Aluminum
S - Steel

6 Port Size

Code	Port Size	Housing Number	
		Aluminum Fatigue Rated	Steel Fatigue Rated
4T	SAE 4	02-160741	02-160745
6T	SAE 6	02-160742	02-160744
2G	1/4" BSPP	02-160739	02-160743
3G	3/8" BSPP	02-160740	02-160746

7 Cracking Pressure
15 - 1,0 bar (15 psi)
35 - 2,4 bar (35 psi)
65 - 4,5 bar (65 psi)

8 Special Features
00 - None
(Only required if valve has special features, omitted if "00")
SS - 316 Stainless Steel external components

Dimensions

mm (inch)

Note: Torque cartridge in aluminum or steel housing to 34-41 Nm (25-30 ft lbs).

Cartridge Drawing

Basic Code
SPC2-8

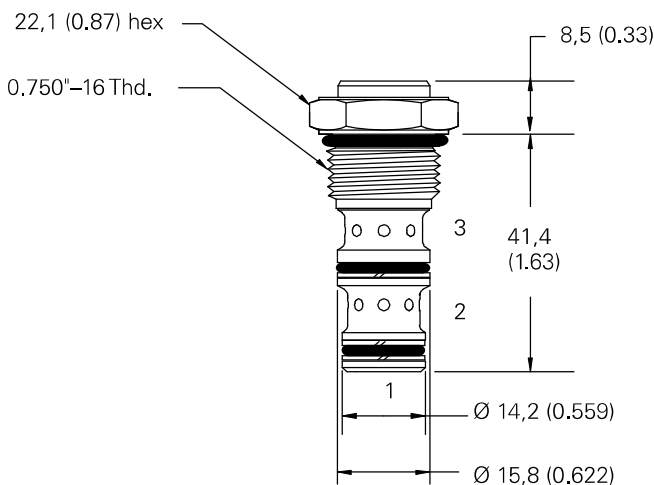

Installation Drawing (Steel)

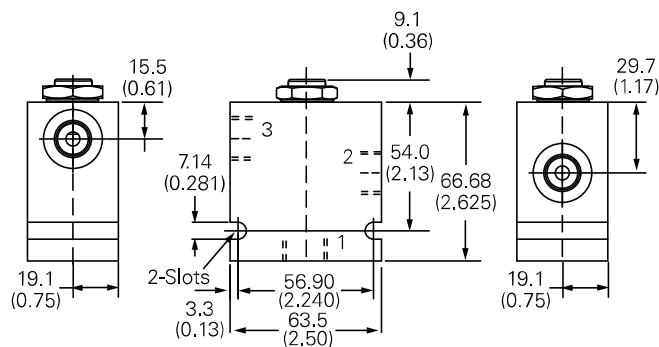

WARNING

Aluminum housings can be used for pressures up to 210 bar (3000 psi). Steel housings must be used for operating pressures above 210 bar (3000 psi).