

# ICEB30 - Overcenter valve

Fully balanced, pilot assisted, relief with check  
30 L/min (8 USgpm) • 270 bar (4000 psi)

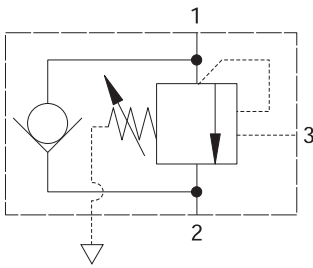

## Sectional View

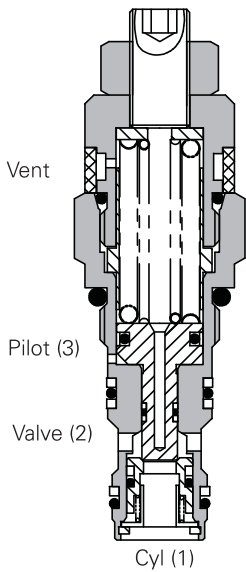

## Operation

The check section allows free flow into the actuator then holds and locks the load against movement. The pilot assisted relief valve section will give controlled movement when pilot pressure is applied. The relief section is normally set to open at a pressure at least 1.3 times the maximum load induced pressure but the pressure required to open the

valve and allow movement depends on the pilot ratio of the valve. For optimization of load control and energy usage, a choice of pilot ratios is available.

The pressure required to open the valve and start actuator movement can be calculated as follows:

$$\text{Pilot Pressure} = \frac{(\text{Relief Setting}) - (\text{Load Pressure})}{\text{Pilot Ratio}}$$

## Features

Cartridge is economical and fits simple cavity. Allows quick, easy field service - reduces down time. Interchangeable with pilot check valve of a similar size.

## Pilot ratio

5.1:1 (standard) Best suited for applications where load varies and machine structure can induce instability.

**Note:** This valve is not suitable for high frequency applications and aggressive environmental conditions.

## Performance data

### Ratings and specifications

Figures based on: Oil Tem = 40°C Viscosity = 32 cSt (150 SUS)

Rated flow	30 L/min (8 USgpm)
Max relief pressure	350 bar (5000 psi)
Max load induced pressure	270 bar (4000 psi)
Cartridge material	Working parts hardened and ground steel. External surfaces zinc plated.
Standard housing material	Aluminum (up to 210 bar). Add suffix "377" for steel option.
Mounting position	Unrestricted
Cavity number	A6610 (See Section M)
Torque cartridge into cavity	45 Nm (33 lbs ft)
Weight	1CEB30 0.14 kg (0.30 lbs) 1CEB35 0.40 kg (0.88 lbs) 1CEE34 0.88 kg (1.94 lbs)
Seal kit number	SK395 (Nitrile) SK395V (Viton®)
Recommended filtration level	BS5540/4 Class 18/13 (25 micron nominal)
Operating temperature	-30°C to +90°C (-22° to +194°F)
Leakage	0.3 milliliters/min nominal (5 dpm)
Nominal viscosity range	5 to 500 cSt

Viton is a registered trademark of E.I. DuPont.

## Pressure drop

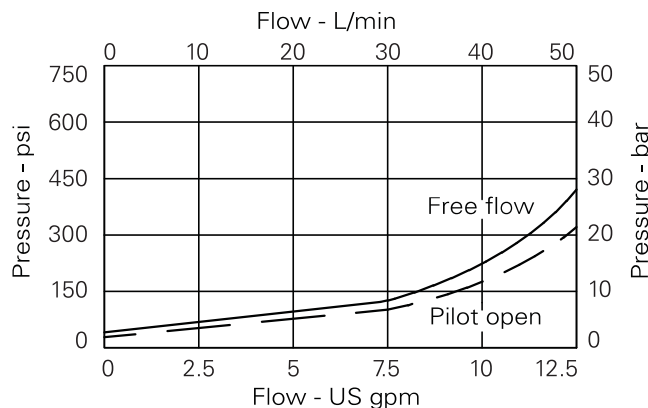

## Description

Overcenter valves give static and dynamic control of loads by supplying a counterbalance pressure to the actuator. They prevent runaway in the event of hose burst and hold the load with minimal leakage.

The pressure balanced valve is unaffected by back pressure, allowing service line reliefs to operate and for the valve to be used in regenerative or proportional valve systems.

The overcenter valve should be mounted either into, onto or as close to the actuator as possible to give maximum protection.

Single overcenter valves control unidirectional loads such as in aerial platforms, cranes or winches and dual overcenters are suited to bi-directional motion such as wheel motor applications or cylinders going over center.

Where measurements are critical request certified drawings. We reserve the right to change specifications without notice.

# 1CEB30 - Overcenter valve

Fully balanced, pilot assisted, relief with check  
30 L/min (8 USgpm) • 270 bar (4000 psi)

## Model code

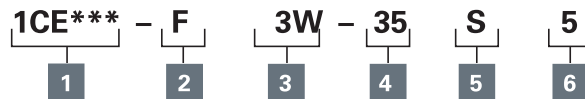

### 1 Function

**1CEB30** - Cartridge Only  
**1CEB35** - Cartridge and Body  
**1CEEB34** - Cartridges and Dual Body

### 2 Adjustment means

**F** - Screw Adjustment

**N** - Fixed - State pressure setting required.

For fixed versions add setting in 10 bar increments to end of part number. Subject to a ±10% tolerance.

### Dimensions

mm (inch)

### Cartridge only

Basic Code

**1CEB30**

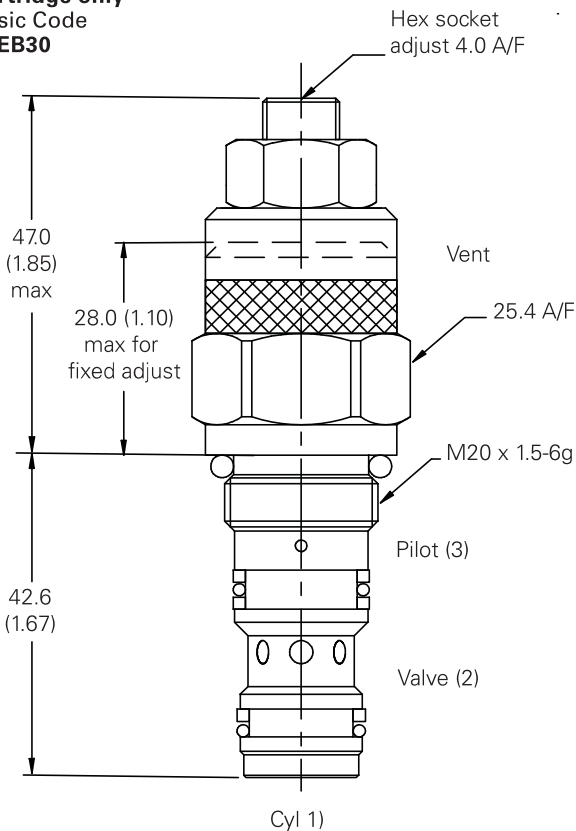

**Note:** For applications above 210 bar - please consult our technical department or use the steel body option

**Note:** Tightening torque of "F" adjuster locknut - 20 to 25 Nm

### 3 Port sizes

Code	Port size	Housing number - body only			
		Aluminium single	Steel single	Aluminium dual	Steel dual
<b>3W</b>	3/8" BSP Valve & Cyl Port 1/4" BSP Pilot Port	B6743	B12823	B6836	B13803
<b>6T</b>	3/8" SAE Valve & Cyl Port 1/4" SAE Pilot Port	B10536		B10805	
<b>8T</b>	1/2" SAE Valve & Cyl Port 1/4" SAE Pilot Port	B7884	B11811	B30237	B11812

### 4 Pressure range

@ 4.8 L/min

**Note:** Code based on pressure in bar.

**35** - 100-350 bar.

Std setting 210 bar

Std setting made at 4.8 L/min

### 5 Seals

**S** -Nitrile (For use with most industrial hydraulic oils)

**SV** -Viton (For high temperature and most special fluid applications)

### 6 Pilot ratio

**5** - 5:1

### Single valve

3/8". 1/2" Ports

Basic Code

**1CEB35**

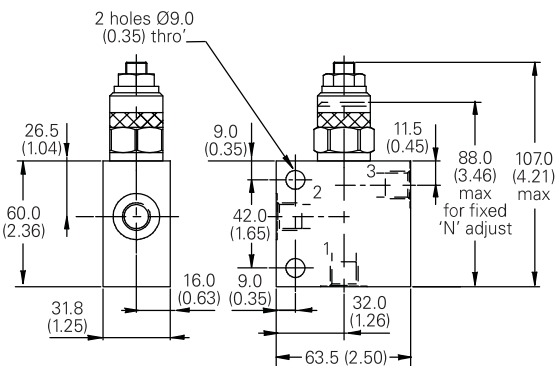

### Dual valve

3/8". 1/2" Ports

Basic Code

**1CEEB34**

Internally Cross Piloted

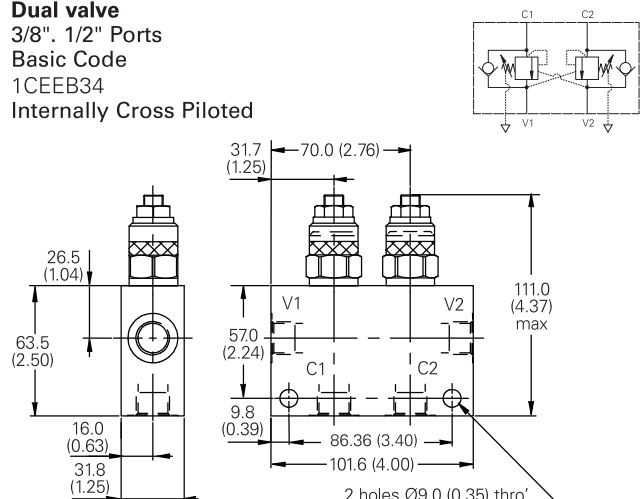

Where measurements are critical request certified drawings. We reserve the right to change specifications without notice.