

# ICEB120 - Overcenter valve

Fully balanced, pilot assisted relief with check  
120 L/min (32 USgpm). 270 bar (4000 psi)

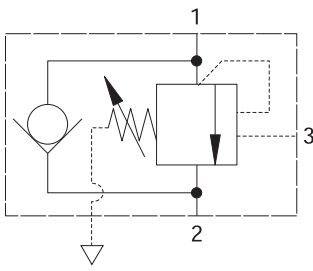

## Operation

The check section allows free flow into the actuator then holds and locks the load against movement. The pilot assisted relief valve section will give controlled movement when pilot pressure is applied. The relief section is normally set to open at a pressure at least 1.3 times the maximum load induced pressure but the pressure required to open the

valve and allow movement depends on the pilot ratio of the valve. For optimization of load control and energy usage, a choice of pilot ratios is available.

The pressure required to open the valve and start actuator movement can be calculated as follows:

$$\text{Pilot Pressure} = \frac{(\text{Relief Setting}) - (\text{Load Pressure})}{\text{Pilot Ratio}}$$

## Features

Cartridge is economical and fits simple cavity. Allows quick, easy field service - reduces down time. Interchangeable with pilot check valve of a similar size.

## Pilot ratio

3:1 (standard) Best suited for applications where load varies and machine structure can induce instability.

8:1 Best suited for applications where the load remains relatively constant.

## Sectional view

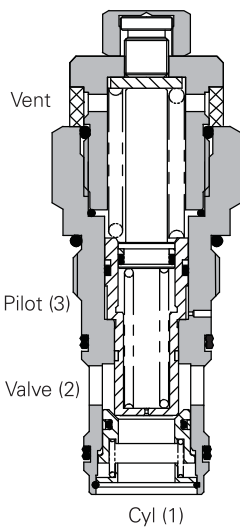

## Performance data

### Ratings and specifications

Figures based on: Oil Temp = 40°C Viscosity = 32 cSt (150 SUS)

Rated flow	120 L/min (32 USgpm)
Max relief setting	350 bar (5000 psi)
Max load induced pressure	270 bar (4000 psi)
Cartridge material	Working parts hardened and ground steel. External surfaces zinc plated.
Standard housing material	Aluminum (up to 210 bar). Add suffix "377" for steel option.
Mounting position	Unrestricted
Cavity number	A877 (See Section M)
Torque cartridge into cavity	100 Nm (74 lbs ft)
Weight	1CEB120 0.59 kg (1.30 lbs) 1CEB150 1.46 kg (3.20 lbs) 1CEE150 2.58 kg (5.70 lbs)
Seal kit number	SK417 (Nitrile) SK417V (Viton®)
Recommended filtration level	BS5540/4 Class 18/13 (25 micron nominal)
Operating temperature	-30° to +90°C (-22° to +194°F)
Leakage	0.3 milliliters/min nominal (5 dpm)
Nominal viscosity range	5 to 500 cSt

Viton is a registered trademark of E.I. DuPont.

## Pressure drop

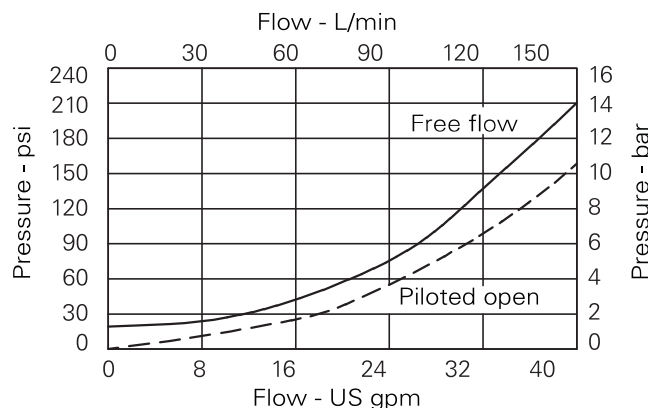

## Description

Overcenter valves give static and dynamic control of loads by supplying a counterbalance pressure to the actuator. They prevent runaway in the event of hose burst and hold the load with minimal leakage.

The pressure balanced valve is unaffected by back pressure, allowing service line reliefs to operate and for the valve to be used in regenerative or proportional valve systems.

The overcenter valve should be mounted either into, onto or as close to the actuator as possible to give maximum protection.

Single overcenter valves control unidirectional loads such as in aerial platforms, cranes or winches and dual overcenters are suited to bi-directional motion such as wheel motor applications or cylinders going over center.

Where measurements are critical request certified drawings. We reserve the right to change specifications without notice.

# ICEB120 - Overcenter valve

Fully balanced, pilot assisted relief with check  
120 L/min (32 USgpm). 270 bar (4000 psi)

## Model code

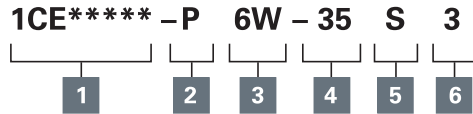

### 1 Function

- 1CEB120** - Cartridge only
- 1CEB150** - Cartridge in body
- 1CEEB150** - Cartridges in dual body

### 2 Adjustment means

**P** - Leakproof screw adjustment

### 3 Port sizes

Code	Port Size	Housing number - body only			
		Aluminium single	Steel single	Aluminium dual	Steel dual
<b>6W</b>	3/4" BSP Valve & Cyl Port. 1/4" BSP Pilot Port	B6898	B5544	C2543	C1200
<b>12T</b>	3/4" SAE Valve & Cyl Port. 1/4" SAE Pilot Port	B8200		C10629	C16434
<b>16T</b>	1" SAE Valve & Cyl Port. 1/4" SAE Pilot Port	B10708	B11814		

### 4 Pressure range @ 4.8 l/min

**Note:** Code based on pressure in bar.

**35** - 70-350 bar.  
Std setting 210 bar  
Std setting made at 4.8 L/min

### 5 Seals

- S** - Nitrile (For use with most industrial hydraulic oils)
- SV** - Viton (For high temperature and most special fluid applications)
- P** - Polyurethane/Nitrile (For arduous applications)

### 6 Pilot ratio

- 3** - 3:1 (Standard)
- 8** - 8:1

## Dimensions

mm (inch)

### Cartridge only

Basic Code  
ICEB120

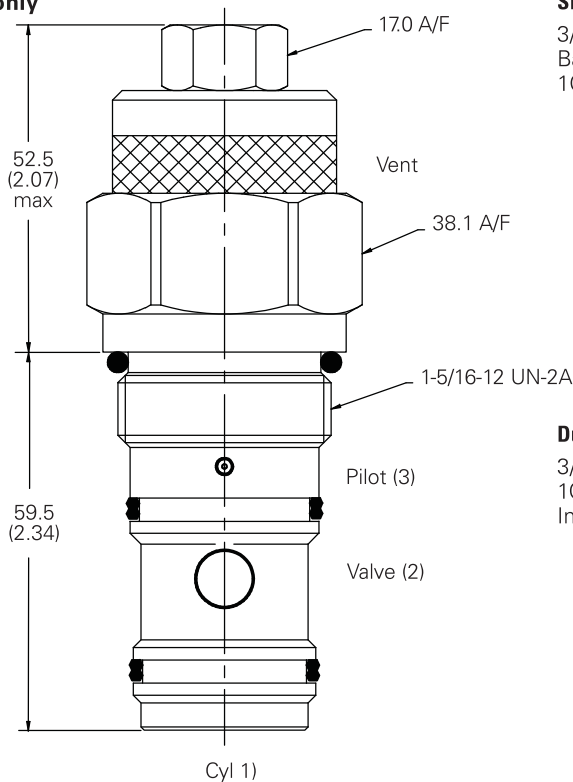

**Note:** For applications above 210 bar - please consult our technical department or use the steel body option

**Note:** Tightening torque of "F" adjuster locknut - 20 to 25 Nm.

### Single valve

3/4", 1" Ports  
Basic Code  
1CEB150

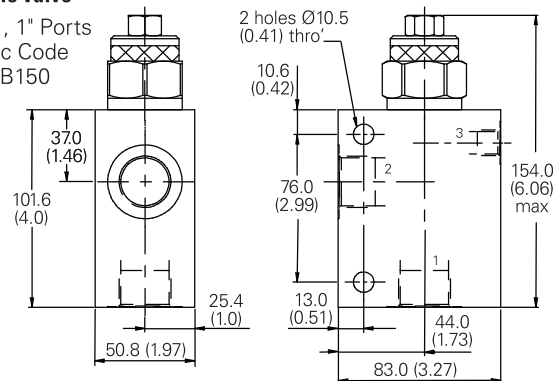

### Dual valve

3/4" Ports  
1CEEB150  
Internally Cross Piloted

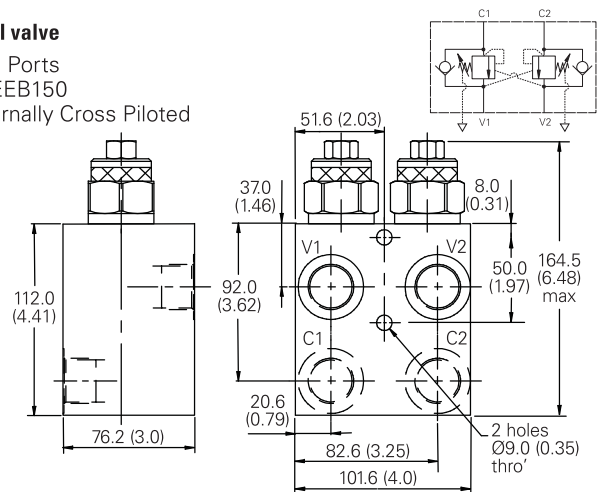

Where measurements are critical request certified drawings. We reserve the right to change specifications without notice.