

**Impro**  
Fluidtek

Technical Information

# Orbital Motors Type WS



[www.Improfluidtek.com](http://www.Improfluidtek.com)



**TABLE OF CONTENTS**

**TECHNICAL INFORMATION**

Operating Recommendations ..... 4-5  
 Motor Connections ..... 5  
 Product Testing (Understanding the Performance Charts) ..... 6  
 Allowable Bearing & Shaft Loads ..... 7  
 Vehicle Drive Calculations ..... 8-9  
 Induced Side Loading ..... 10  
 Hydraulic Equations ..... 10  
 Shaft Nut Dimensions & Torque Specifications ..... 11

**OPTIONAL MOTOR FEATURES**

Speed Sensor Options ..... 12-13  
 Freeturning Rotor Option ..... 13  
 Internal Drain ..... 14  
 Valve Cavity Option ..... 15  
 Slinger Seal Option ..... 15

**HEAVY DUTY HYDRAULIC MOTORS**

WS 365 & 366 Product Line Introduction ..... 16  
 WS 365 & 366 Displacement Performance Charts ..... 17-22  
 365 & 366 Series Housings ..... 23-24  
 365 & 366 Series Technical Information ..... 25  
 365 & 366 Series Porting Options ..... 26-27  
 365 & 366 Series Shafts ..... 27-28  
 365 & 366 Series Short Motor Information ..... 29  
 365 & 366 Series Ordering Information ..... 30

WS 360 Product Line Introduction ..... 31  
 WS 360 Displacement Performance Charts ..... 32-36  
 360 Series Housings ..... 37-38  
 360 Series Technical Information ..... 39-40  
 360 Series Porting Options ..... 41  
 360 Series Shafts ..... 42-43  
 360 Series Short Motor Information ..... 44  
 360 Series Ultra Short Motor Information ..... 45-46  
 360 Series Ordering Information ..... 47

## OPERATING RECOMMENDATIONS

### OIL TYPE

Hydraulic oils with anti-wear, anti-foam and demulsifiers are recommended for systems incorporating Impro Fluidtek motors. Straight oils can be used but may require VI (viscosity index) improvers depending on the operating temperature range of the system. Other water based and environmentally friendly oils may be used, but service life of the motor and other components in the system may be significantly shortened. Before using any type of fluid, consult the fluid requirements for all components in the system for compatibility. Testing under actual operating conditions is the only way to determine if acceptable service life will be achieved.

### FLUID VISCOSITY & FILTRATION

Fluids with a viscosity between 20 - 43 cSt [100 - 200 S.U.S.] at operating temperature is recommended. Fluid temperature should also be maintained below 85°C [180° F]. It is also suggested that the type of pump and its operating specifications be taken into account when choosing a fluid for the system. Fluids with high viscosity can cause cavitation at the inlet side of the pump. Systems that operate over a wide range of temperatures may require viscosity improvers to provide acceptable fluid performance.

Impro Fluidtek recommends maintaining an oil cleanliness level of ISO 17-14 or better.

### INSTALLATION & START-UP

When installing an Impro Fluidtek motor it is important that the mounting flange of the motor makes full contact with the mounting surface of the application. Mounting hardware of the appropriate grade and size must be used. Hubs, pulleys, sprockets and couplings must be properly aligned to avoid inducing excessive thrust or radial loads. Although the output device must fit the shaft snug, a hammer should never be used to install any type of output device onto the shaft. The port plugs should only be removed from the motor when the system connections are ready to be made. To avoid contamination, remove all matter from around the ports of the motor and the threads of the fittings. Once all system connections are made, it is recommended that the motor be run-in for 15-30 minutes at no load and half speed to remove air from the hydraulic system.

### MOTOR PROTECTION

Over-pressurization of a motor is one of the primary causes of motor failure. To prevent these situations, it is necessary to provide adequate relief protection for a motor based on the pressure ratings for that particular model. For systems that may experience overrunning conditions, special precautions must be taken. In an overrunning condition, the motor functions as a pump and attempts to convert kinetic energy into hydraulic energy. Unless the system is properly

configured for this condition, damage to the motor or system can occur. To protect against this condition a counterbalance valve or relief cartridge must be incorporated into the circuit to reduce the risk of over-pressurization. If a relief cartridge is used, it must be installed upline of the motor, if not in the motor, to relieve the pressure created by the over-running motor. To provide proper motor protection for an over-running load application, the pressure setting of the pressure relief valve must not exceed the intermittent rating of the motor.

### HYDRAULIC MOTOR SAFETY PRECAUTION

A hydraulic motor must not be used to hold a suspended load. Due to the necessary internal tolerances, all hydraulic motors will experience some degree of creep when a load induced torque is applied to a motor at rest. All applications that require a load to be held must use some form of mechanical brake designed for that purpose.

### MOTOR/BRAKE PRECAUTION

**Caution!** - Impro Fluidtek motor/brakes are intended to operate as static or parking brakes. System circuitry must be designed to bring the load to a stop before applying the brake.

**Caution!** - Because it is possible for some large displacement motors to overpower the brake, it is critical that the maximum system pressure be limited for these applications. Failure to do so could cause serious injury or death. When choosing a motor/brake for an application, consult the performance chart for the series and displacement chosen for the application to verify that the maximum operating pressure of the system will not allow the motor to produce more torque than the maximum rating of the brake. Also, it is vital that the system relief be set low enough to insure that the motor is not able to overpower the brake.

To ensure proper operation of the brake, a separate case drain back to tank must be used. Use of the internal drain option is not recommended due to the possibility of return line pressure spikes. A simple schematic of a system utilizing a motor/brake is shown on page 5. Although maximum brake release pressure may be used for an application, a 34 bar [500 psi] pressure reducing valve is recommended to promote maximum life for the brake release piston seals. However, if a pressure reducing valve is used in a system which has case drain back pressure, the pressure reducing valve should be set to 34 bar [500 psi] over the expected case pressure to ensure full brake release. To achieve proper brake release operation, it is necessary to bleed out any trapped air and fill brake release cavity and hoses before all connections are tightened. To facilitate this operation, all motor/brakes feature two release ports. One or both of these ports may be used to release the brake in the

**OPERATING RECOMMENDATIONS & MOTOR CONNECTIONS**

**MOTOR/BRAKE PRECAUTION** (continued)

unit. Motor/brakes should be configured so that the release ports are near the top of the unit in the installed position.

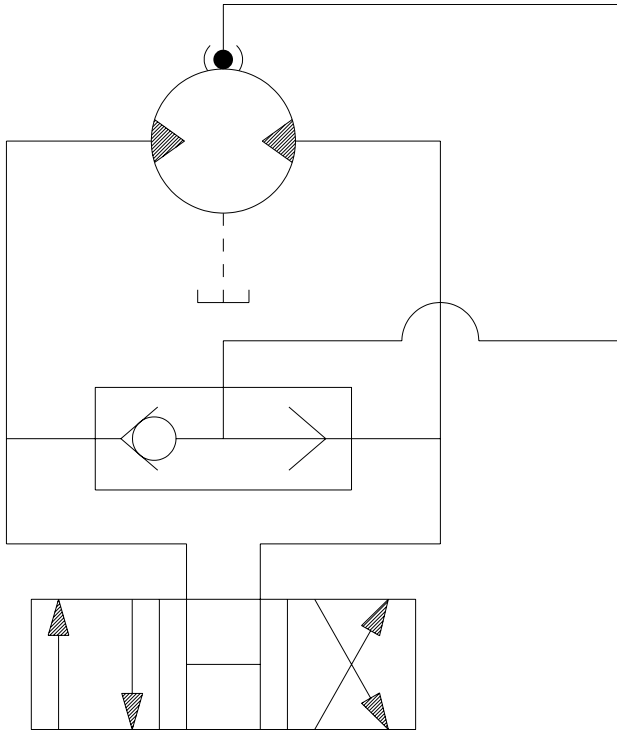

TYPICAL MOTOR/BRAKE SCHEMATIC

Once all system connections are made, one release port must be opened to atmosphere and the brake release line carefully charged with fluid until all air is removed from the line and motor/brake release cavity. When this has been accomplished the port plug or secondary release line must be reinstalled. In the event of a pump or battery failure, an external pressure source may be connected to the brake release port to release the brake, allowing the machine to be moved.

► NOTE: It is vital that all operating recommendations be followed. Failure to do so could result in injury or death.

**MOTOR CIRCUITS**

There are two common types of circuits used for connecting multiple numbers of motors – series connection and parallel connection.

**SERIES CONNECTION**

When motors are connected in series, the outlet of one motor is connected to the inlet of the next motor. This allows the full pump flow to go through each motor and provide maximum speed. Pressure and torque are distributed between the motors based on the load each motor is subjected to. The maximum system pressure must be no greater than the maximum inlet pressure of the first motor. The allowable back pressure rating for a motor must also be considered. In some series circuits the motors must have an external case drain connected. A series connection is desirable when it is important for all the motors to run the same speed such as on a long line conveyor.

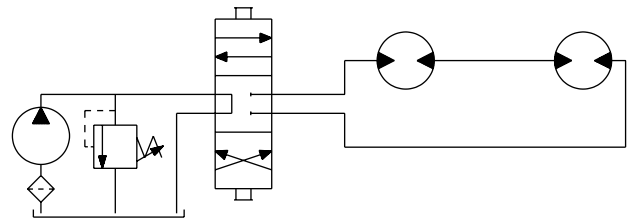

SERIES CIRCUIT

**PARALLEL CONNECTION**

In a parallel connection all of the motor inlets are connected. This makes the maximum system pressure available to each motor allowing each motor to produce full torque at that pressure. The pump flow is split between the individual motors according to their loads and displacements. If one motor has no load, the oil will take the path of least resistance and all the flow will go to that one motor. The others will not turn. If this condition can occur, a flow divider is recommended to distribute the oil and act as a differential.

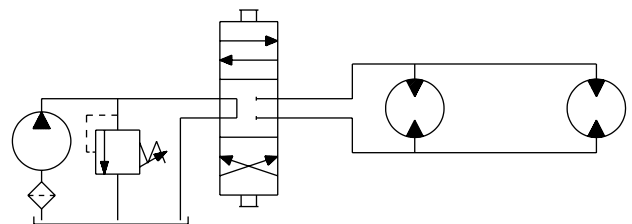

PARALLEL CIRCUIT

► NOTE: The motor circuits shown above are for illustration purposes only. Components and circuitry for actual applications may vary greatly and should be chosen based on the application.

## PRODUCT TESTING

Performance testing is the critical measure of a motor's ability to convert flow and pressure into speed and torque. All product testing is conducted using an Impro Fluidtek state of the art test facility. This facility utilizes fully automated test equipment and custom designed software to provide accurate, reliable test data. Test routines are standardized, including test stand calibration and stabilization of fluid temperature and viscosity, to provide consistent data. The example below provides an explanation of the values pertaining to each heading on the performance chart.

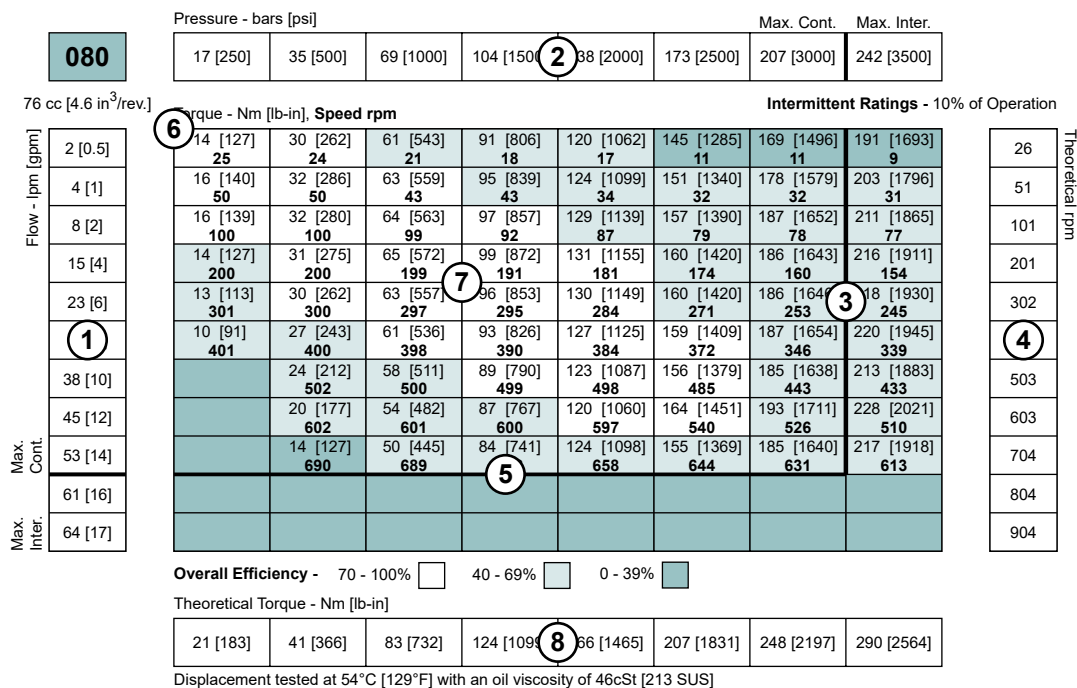

- Flow represents the amount of fluid passing through the motor during each minute of the test.
- Pressure refers to the measured pressure differential between the inlet and return ports of the motor during the test.
- The maximum continuous pressure rating and maximum intermittent pressure rating of the motor are separated by the dark lines on the chart.
- Theoretical RPM represents the RPM that the motor would produce if it were 100% volumetrically efficient. Measured RPM divided by the theoretical RPM give the actual volumetric efficiency of the motor.
- The maximum continuous flow rating and maximum intermittent flow rating of the motor are separated by the dark line on the chart.
- Performance numbers represent the actual torque and speed generated by the motor based on the corresponding input pressure and flow. The numbers on the top row indicate torque as measured in Nm [lb-in], while the bottom number represents the speed of the output shaft.
- Areas within the white shading represent maximum motor efficiencies.
- Theoretical Torque represents the torque that the motor would produce if it were 100% mechanically efficient. Actual torque divided by the theoretical torque gives the actual mechanical efficiency of the motor.

**ALLOWABLE BEARING & SHAFT LOADING**

This catalog provides curves showing allowable radial loads at points along the longitudinal axis of the motor. They are dimensioned from the mounting flange. Two capacity curves for the shaft and bearings are shown. A vertical line through the centerline of the load drawn to intersect the x-axis intersects the curves at the load capacity of the shaft and of the bearing.

In the example below the maximum radial load bearing rating is between the internal roller bearings illustrated with a solid line. The allowable shaft rating is shown with a dotted line.

The bearing curves for each model are based on laboratory analysis and testing results constructed at Impro Fluidtek. The shaft loading is based on a 3:1 safety factor and 330 Kpsi tensile strength. The allowable load is the lower of the curves at a given point. For instance, one inch in front of the mounting flange the bearing capacity is lower than the shaft capacity. In this case, the bearing is the limiting load. The motor user needs to determine which series of motor to use based on their application knowledge.

**ISO 281 RATINGS VS. MANUFACTURERS RATINGS**

Published bearing curves can come from more than one type of analysis. The ISO 281 bearing rating is an international standard for the dynamic load rating of roller bearings. The rating is for a set load at a speed of 33 1/3 RPM for 500 hours (1 million revolutions). The standard was established to allow consistent comparisons of similar bearings between manufacturers. The ISO 281 bearing ratings are based solely on the physical characteristics of the bearings, removing any manufacturers specific safety factors or empirical data that influences the ratings.

Manufacturers' ratings are adjusted by diverse and systematic laboratory investigations, checked constantly with feedback from practical experience. Factors taken into account that affect bearing life are material, lubrication, cleanliness of the lubrication, speed, temperature, magnitude of the load and the bearing type.

The operating life of a bearing is the actual life achieved by the bearing and can be significantly different from the calculated life. Comparison with similar applications is the most accurate method for bearing life estimations.

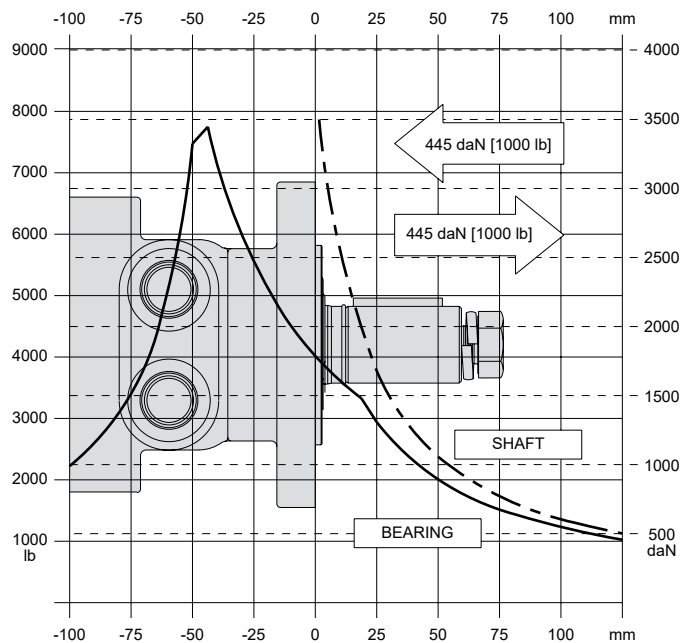

**EXAMPLE LOAD RATING FOR MECHANICALLY RETAINED NEEDLE ROLLER BEARINGS**

- Bearing Life  $L_{10}$  =  $(C/P)^p$  [ $10^6$  revolutions]
- $L_{10}$  = nominal rating life
- C = dynamic load rating
- P = equivalent dynamic load
- Life Exponent  $P$  = 10/3 for needle bearings

BEARING LOAD MULTIPLICATION FACTOR TABLE			
RPM	FACTOR	RPM	FACTOR
50	1.23	500	0.62
100	1.00	600	0.58
200	0.81	700	0.56
300	0.72	800	0.50
400	0.66		

## VEHICLE DRIVE CALCULATIONS

When selecting a wheel drive motor for a mobile vehicle, a number of factors concerning the vehicle must be taken into consideration to determine the required maximum motor RPM, the maximum torque required and the maximum load each motor must support. The following sections contain the necessary equations to determine this criteria. An example is provided to illustrate the process.

### Sample application (vehicle design criteria)

vehicle description..... 4 wheel vehicle  
 vehicle drive.....2 wheel drive  
 GVW .....1,500lbs.  
 weight over each drive wheel ..... 425 lbs.  
 rolling radius of tires ..... 16 in.  
 desired acceleration .....0-5 mph in 10 sec.  
 top speed..... 5 mph  
 gradability.....20%  
 worst working surface..... poor asphalt

### To determine maximum motor speed

$$\text{RPM} = \frac{2.65 \times \text{KPH} \times G}{r_m} \qquad \text{RPM} = \frac{168 \times \text{MPH} \times G}{r_i}$$

Where:

MPH = max. vehicle speed (miles/hr)  
 KPH = max. vehicle speed (kilometers/hr)  
 $r_i$  = rolling radius of tire (inches)  
 G = gear reduction ratio (if none, G = 1)  
 $r_m$  = rolling radius of tire (meters)

**Example**  $\text{RPM} = \frac{168 \times 5 \times 1}{16} = 52.5$

### To determine maximum torque requirement of motor

To choose a motor(s) capable of producing enough torque to propel the vehicle, it is necessary to determine the Total Tractive Effort (TE) requirement for the vehicle. To determine the total tractive effort, the following equation must be used:

$$\text{TE} = \text{RR} + \text{GR} + \text{FA} + \text{DP} \text{ (lbs or N)}$$

Where:

TE = Total tractive effort  
 RR = Force necessary to overcome rolling resistance  
 GR = Force required to climb a grade  
 FA = Force required to accelerate  
 DP = Drawbar pull required

The components for this equation may be determined using the following steps:

### Step One: Determine Rolling Resistance

Rolling Resistance (RR) is the force necessary to propel a vehicle over a particular surface. It is recommended that the worst possible surface type to be encountered by the vehicle be factored into the equation.

$$\text{RR} = \frac{\text{GVW}}{1000} \times R \text{ (lb or N)}$$

Where:

GVW = gross (loaded) vehicle weight (lb or kg)  
 R = surface friction (value from Table 1)

---

**Example**  $\text{RR} = \frac{1500}{1000} \times 22 \text{ lbs} = 33 \text{ lbs}$

Table 1

Rolling Resistance	
Concrete (excellent).....	10
Concrete (good).....	15
Concrete (poor).....	20
Asphalt (good).....	12
Asphalt (fair).....	17
Asphalt (poor).....	22
Macadam (good).....	15
Macadam (fair).....	22
Macadam (poor).....	37
Cobbles (ordinary).....	55
Cobbles (poor).....	37
Snow (2 inch).....	25
Snow (4 inch).....	37
Dirt (smooth).....	25
Dirt (sandy).....	37
Mud.....	37 to 150
Sand (soft).....	60 to 150
Sand (dune).....	160 to 300

### Step Two: Determine Grade Resistance

Grade Resistance (GR) is the amount of force necessary to move a vehicle up a hill or "grade." This calculation must be made using the maximum grade the vehicle will be expected to climb in normal operation.

To convert incline degrees to % Grade:

$$\% \text{ Grade} = [\tan \text{ of angle (degrees)}] \times 100$$

$$\text{GR} = \frac{\% \text{ Grade}}{100} \times \text{GVW} \text{ (lb or N)}$$

**Example**  $\text{GR} = \frac{20}{100} \times 1500 \text{ lbs} = 300 \text{ lbs}$

**VEHICLE DRIVE CALCULATIONS**

**Step Three: Determine Acceleration Force**

Acceleration Force (FA) is the force necessary to accelerate from a stop to maximum speed in a desired time.

$$FA = \frac{MPH \times GVW \text{ (lb)}}{22 \times t} \qquad FA = \frac{KPH \times GVW \text{ (N)}}{35.32 \times t}$$

Where:

t = time to maximum speed (seconds)

**Example**  $FA = \frac{5 \times 1500 \text{ lbs}}{22 \times 10} = 34 \text{ lbs}$

**Step Four: Determine Drawbar Pull**

Drawbar Pull (DP) is the additional force, if any, the vehicle will be required to generate if it is to be used to tow other equipment. If additional towing capacity is required for the equipment, repeat steps one through three for the towable equipment and sum the totals to determine DP.

**Step Five: Determine Total Tractive Effort**

The Tractive Effort (TE) is the sum of the forces calculated in steps one through three above. On low speed vehicles, wind resistance can typically be neglected. However, friction in drive components may warrant the addition of 10% to the total tractive effort to insure acceptable vehicle performance.

$$TE = RR + GR + FA + DP \text{ (lb or N)}$$

**Example**  $TE = 33 + 300 + 34 + 0 \text{ (lbs)} = 367 \text{ lbs}$

**Step Six: Determine Motor Torque**

The Motor Torque (T) required per motor is the Total Tractive Effort divided by the number of motors used on the machine. Gear reduction is also factored into account in this equation.

$$T = \frac{TE \times ri}{M \times G} \text{ lb-in per motor} \qquad T = \frac{TE \times rm}{M \times G} \text{ Nm per motor}$$

Where:

M = number of driving motors

**Example**  $T = \frac{367 \times 16}{2 \times 1} \text{ lb-in/motor} = 2936 \text{ lb-in}$

**Step Seven: Determine Wheel Slip**

To verify that the vehicle will perform as designed in regards to tractive effort and acceleration, it is necessary to calculate wheel slip (TS) for the vehicle. In special cases, wheel slip may actually be desirable to prevent hydraulic system overheating and component breakage should the vehicle become stalled.

$$TS = \frac{W \times f \times ri}{G} \qquad TS = \frac{W \times f \times rm}{G}$$

(lb-in per motor)      (N-m per motor)

Where:

f = coefficient of friction (see table 2)

W = loaded vehicle weight over driven wheel (lb or N)

**Example**  $TS = \frac{425 \times .06 \times 16}{1} \text{ lb-in/motor} = 4080 \text{ lbs}$

Table 2

Coefficient of friction (f)	
Steel on steel.....	0.3
Rubber tire on dirt.....	0.5
Rubber tire on a hard surface .....	0.6 - 0.8
Rubber tire on cement.....	0.7

**To determine radial load capacity requirement of motor**

When a motor used to drive a vehicle has the wheel or hub attached directly to the motor shaft, it is critical that the radial load capabilities of the motor are sufficient to support the vehicle. After calculating the Total Radial Load (RL) acting on the motors, the result must be compared to the bearing/shaft load charts for the chosen motor to determine if the motor will provide acceptable load capacity and life.

$$RL = \sqrt{W^2 + \left(\frac{T}{ri}\right)^2} \text{ lb} \qquad RL = \sqrt{W^2 + \left(\frac{T}{rm}\right)^2} \text{ kg}$$

**Example**  $RL = \sqrt{425^2 + \left(\frac{2936}{16}\right)^2} = 463 \text{ lbs}$

Once the maximum motor RPM, maximum torque requirement, and the maximum load each motor must support have been determined, these figures may then be compared to the motor performance charts and to the bearing load curves to choose a series and displacement to fulfill the motor requirements for the application.

## INDUCED SIDE LOAD

In many cases, pulleys or sprockets may be used to transmit the torque produced by the motor. Use of these components will create a torque induced side load on the motor shaft and bearings. It is important that this load be taken into consideration when choosing a motor with sufficient bearing and shaft capacity for the application.

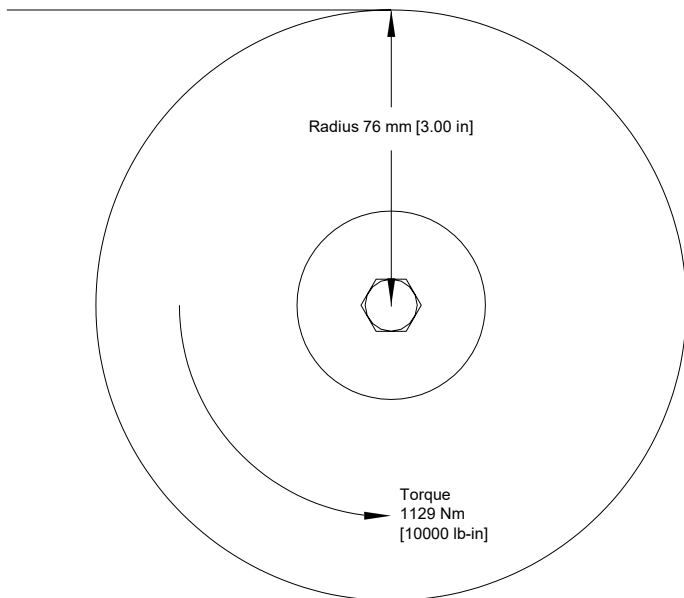

To determine the side load, the motor torque and pulley or sprocket radius must be known. Side load may be calculated using the formula below. The distance from the pulley/sprocket centerline to the mounting flange of the motor must also be determined. These two figures may then be compared to the bearing and shaft load curve of the desired motor to determine if the side load falls within acceptable load ranges.

$$\text{Side Load} = \frac{\text{Torque}}{\text{Radius}}$$

$$\text{Side Load} = 14855 \text{ N [3333 lbs]}$$

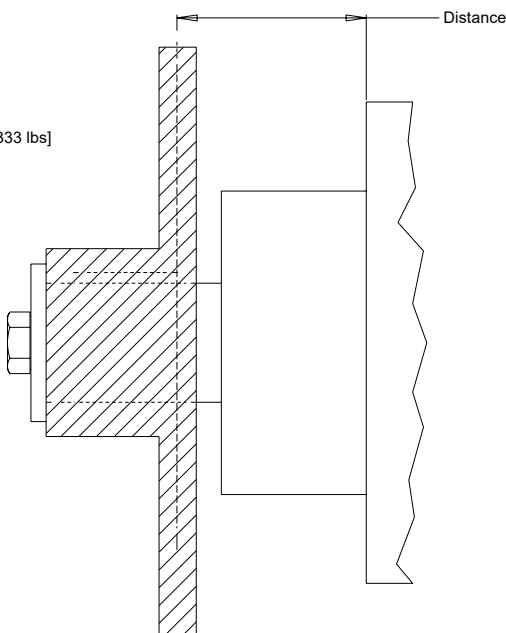

## HYDRAULIC EQUATIONS

Multiplication Factor	Abbrev.	Prefix
10 <sup>12</sup>	T	tera
10 <sup>9</sup>	G	giga
10 <sup>6</sup>	M	mega
10 <sup>3</sup>	K	kilo
10 <sup>2</sup>	h	hecto
10 <sup>1</sup>	da	deka
10 <sup>-1</sup>	d	deci
10 <sup>-2</sup>	c	centi
10 <sup>-3</sup>	m	milli
10 <sup>-6</sup>	u	micro
10 <sup>-9</sup>	n	nano
10 <sup>-12</sup>	p	pico
10 <sup>-15</sup>	f	femto
10 <sup>-18</sup>	a	atto

Theo. Speed (RPM) =

$$\frac{1000 \times \text{LPM}}{\text{Displacement (cm}^3\text{/rev)}} \quad \text{or} \quad \frac{231 \times \text{GPM}}{\text{Displacement (in}^3\text{/rev)}}$$

Theo. Torque (lb-in) =

$$\frac{\text{Bar} \times \text{Disp. (cm}^3\text{/rev)}}{20 \pi} \quad \text{or} \quad \frac{\text{PSI} \times \text{Displacement (in}^3\text{/rev)}}{6.28}$$

Power In (HP) =

$$\frac{\text{Bar} \times \text{LPM}}{600} \quad \text{or} \quad \frac{\text{PSI} \times \text{GPM}}{1714}$$

Power Out (HP) =

$$\frac{\text{Torque (Nm)} \times \text{RPM}}{9543} \quad \text{or} \quad \frac{\text{Torque (lb-in)} \times \text{RPM}}{63024}$$

**SHAFT NUT INFORMATION**

**35MM TAPERED SHAFTS**  
M24 x 1.5 Thread

**A** Slotted Nut

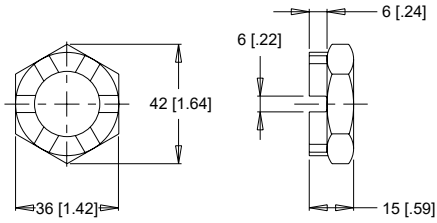

Torque Specifications: 32.5 daNm [240 ft.lb.]

**PRECAUTION**

The tightening torques listed with each nut should only be used as a guideline. Hubs may require higher or lower tightening torque depending on the material. Consult the hub manufacturer to obtain recommended tightening torque. To maximize torque transfer from the shaft to the hub, and to minimize the potential for shaft breakage, a hub with sufficient thickness must fully engage the taper length of the shaft.

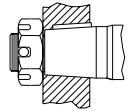

incorrect

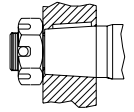

correct

**1" TAPERED SHAFTS**  
3/4-28 Thread

**A** Slotted Nut

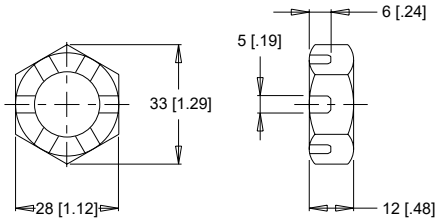

Torque Specifications: 20 - 23 daNm [150 - 170 ft.lb.]

**B** Lock Nut

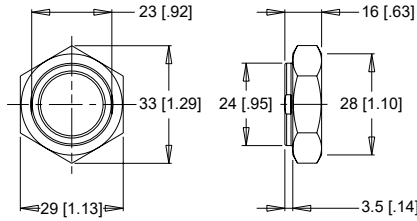

Torque Specifications: 24 - 27 daNm [180 - 200 ft.lb.]

**C** Solid Nut

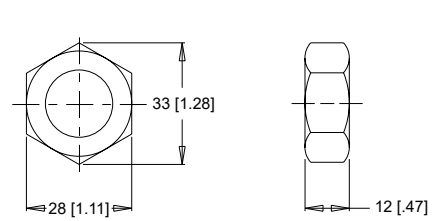

Torque Specifications: 20 - 23 daNm [150 - 170 ft.lb.]

**1-1/4" TAPERED SHAFTS**  
1-20 Thread

**A** Slotted Nut

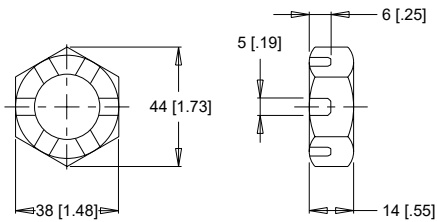

Torque Specifications: 38 daNm [280 ft.lb.] Max.

**B** Lock Nut

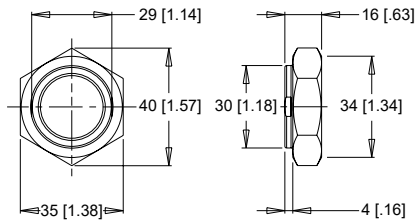

Torque Specifications: 33 - 42 daNm [240 - 310 ft.lb.]

**C** Solid Nut

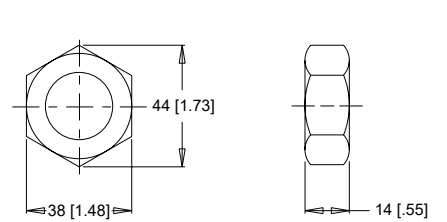

Torque Specifications: 38 daNm [280 ft.lb.] Max.

**1-3/8" & 1-1/2" TAPERED SHAFTS**  
1 1/8-18 Thread

**A** Slotted Nut

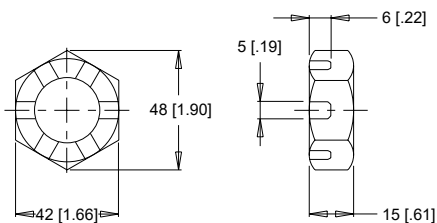

Torque Specifications: 41 - 54 daNm [300 - 400 ft.lb.]

**B** Lock Nut

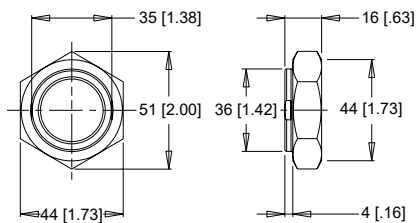

Torque Specifications: 34 - 48 daNm [250 - 350 ft.lb.]

**C** Solid Nut

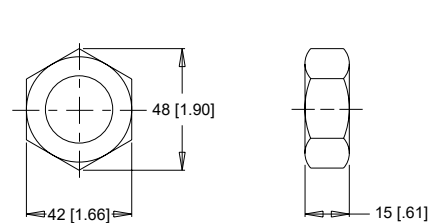

Torque Specifications: 41 - 54 daNm [300 - 400 ft.lb.]

## SPEED SENSORS

Impro Fluidtek offers both single and dual element speed sensor options providing a number of benefits to users by incorporating the latest advancements in sensing technology and materials. The single element sensors provide 50 pulses per revolution with the dual element providing 100 pulses per revolution.” Higher resolution is especially beneficial for slow speed applications, where more information is needed for smooth and accurate control. The dual sensor option also provides a direction signal allowing end-users to monitor the direction of shaft rotation.

Unlike competitive designs that breach the high pressure area of the motor to add the sensor, the Impro Fluidtek speed sensor option utilizes an add-on flange to locate all sensor components outside the high pressure operating environment. This eliminates the potential leak point common to competitive designs. Many improvements were made to the sensor flange including changing the material from cast iron to acetal resin, incorporating a Buna-N shaft seal internal to the flange, and providing a grease zerk, which allows the user to fill the sensor cavity with grease. These improvements enable the flange to withstand the rigors of harsh environments.

Another important feature of the new sensor flange is that it is self-centering, which allows it to remain concentric to the magnet rotor. This produces a consistent mounting location for the new sensor module, eliminating the need to adjust

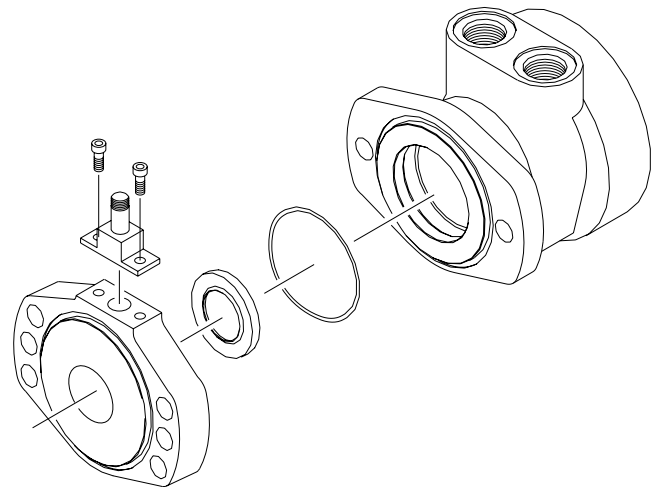

the air gap between the sensor and magnet rotor. The o-ring sealed sensor module attaches to the sensor flange with two small screws, allowing the sensor to be serviced or upgraded in the field in under one minute. This feature is especially valuable for mobile applications where machine downtime is costly. The sensor may also be serviced without exposing the hydraulic circuit to the atmosphere. Another advantage of the self-centering flange is that it allows users to rotate the sensor to a location best suited to their application. This feature is not available on competitive designs, which fix the sensor in one location in relationship to the motor mounting flange.

## FEATURES / BENEFITS

- Grease fitting allows sensor cavity to be filled with grease for additional protection.
- Internal extruder seal protects against environmental elements.
- M12 or weatherpack connectors provide installation flexibility.
- Dual element sensor provides up to 100 pulses per revolution and directional sensing.
- Modular sensor allows quick and easy servicing.
- Acetal resin flange is resistant to moisture, chemicals, oils, solvents and greases.
- Self-centering design eliminates need to set magnet-to-sensor air gap.
- Protection circuitry

## SENSOR OPTIONS

### Z - 4-pin M12 male connector

This option has 50 pulses per revolution on all series. This option will not detect direction.

### Y - 3-pin male weatherpack connector\*

This option has 50 pulses per revolution on all series. This option will not detect direction.

### X - 4-pin M12 male connector

This option has 100 pulses per revolution on all series. This option will detect direction.

### W - 4-pin male weatherpack connector\*

This option has 100 pulses per revolution on all series. This option will detect direction.

\*These options include a 610mm [2 ft] cable.

## SPEED SENSORS

### SINGLE ELEMENT SENSOR - Y & Z

Supply voltages..... 7.5-24 Vdc  
 Maximum output off voltage.....24V  
 Maximum continuous output current..... < 25 ma  
 Signal levels (low, high)..... 0.8 to supply voltage  
 Operating Temp .....-30°C to 83°C [-22°F to 181°F]

### DUAL ELEMENT SENSOR - X & W

Supply voltages..... 7.5-18 Vdc  
 Maximum output off voltage.....18V  
 Maximum continuous output current..... < 20 ma  
 Signal levels (low, high)..... 0.8 to supply voltage  
 Operating Temp .....-30°C to 83°C [-22°F to 181°F]

### SENSOR CONNECTORS

#### Z Option

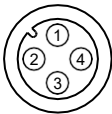

#### PIN

1	positive	brown or red
2	n/a	white
3	negative	blue
4	pulse out	black

#### X Option

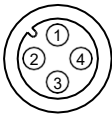

#### PIN

1	positive	brown or red
2	direction out	white
3	negative	blue
4	pulse out	black

#### Y Option

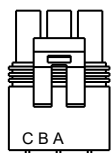

#### PIN

A	positive	brown or red
B	negative	blue
C	pulse out	black
D	n/a	white

#### W Option

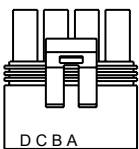

#### PIN

A	positive	brown or red
B	negative	blue
C	pulse out	black
D	direction out	white

### PROTECTION CIRCUITRY

The single element sensor has been improved and incorporates protection circuitry to avoid electrical damage caused by:

- reverse battery protection
- overvoltage due to power supply spikes and surges (60 Vdc max.)
- power applied to the output lead

The protection circuit feature will help “save” the sensor from damage mentioned above caused by:

- faulty installation wiring or system repair
- wiring harness shorts/opens due to equipment failure or harness damage resulting from accidental conditions (i.e. severed or grounded wire, ice, etc.)
- power supply spikes and surges caused by other electrical/electronic components that may be intermittent or damaged and “loading down” the system.

While no protection circuit can guarantee against any and all fault conditions. The single element sensor from Impro Fluidtek with protection circuitry is designed to handle potential hazards commonly seen in real world applications.

Unprotected versions are also available for operation at lower voltages down to 4.5V.

### FREE TURNING ROTOR

The ‘AC’ option or “Free turning” option refers to a specially prepared rotor assembly. This rotor assembly has increased clearance between the rotor tips and rollers allowing it to turn more freely than a standard rotor assembly. For spool valve motors, additional clearance is also provided between the shaft and housing bore. The ‘AC’ option is available for all motor series and displacements.

There are several applications and duty cycle conditions where ‘AC’ option performance characteristics can be beneficial. In continuous duty applications that require high flow/high rpm operation, the benefits are twofold. The additional clearance helps to minimize internal pressure drop at high flows. This clearance also provides a thicker oil film at metal to metal contact areas and can help extend the life of the motor in high rpm or even over speed conditions. The ‘AC’ option should be considered for applications that require continuous operation above 57 LPM [15 GPM] and/or 300 rpm. Applications that are subject to pressure spikes due to frequent reversals or shock loads can also benefit by specifying the ‘AC’ option. The additional clearance serves to act as a buffer against spikes, allowing them to be bypassed through the motor rather than being absorbed and transmitted through the drive link to the output shaft. The trade-off for achieving these benefits is a slight loss of volumetric efficiency at high pressures.

## INTERNAL DRAIN

The internal drain is standard on all WD, WP, WR, WS360. Typically, a separate drain line must be installed to direct case leakage of the motor back to the reservoir when using WS365/366. However, the internal drain option eliminates the need for a separate drain line through the installation of two check valves in the motor. This simplifies plumbing requirements for the motor.

The two check valves connect the case area of the motor to each port of the endcover. During normal motor operation, pressure in the input and return lines of the motor close the check valves. However, when the pressure in the case of the motor is greater than that of the return line, the check valve between the case and low pressure line opens, allowing the case leakage to flow into the return line. Since the operation of the check valves is dependent upon a pressure differential, the internal drain option operates in either direction of motor rotation.

Although this option can simplify many motor installations, precautions must be taken to insure that return line pressure remains below allowable levels (see table below) to insure proper motor operation and life. If return line pressure is higher than allowable, or experiences pressure spikes, this pressure may feed back into the motor, possibly causing catastrophic seal failure. Installing motors with internal drains in series is not recommended unless overall pressure drop over all motors is below the maximum allowable backpressure as listed in the chart below. If in doubt, contact your authorized Impro Fluidtek representative.

MAXIMUM ALLOWABLE BACK PRESSURE		
Series	Cont. bar [psi]	Inter. bar [psi]
Brakes	34 [500]	34 [500]

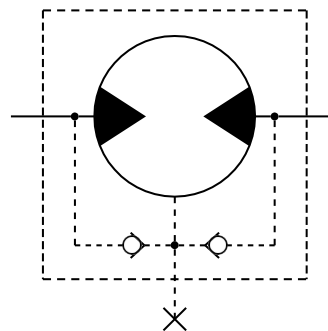

## VALVE CAVITY

The valve cavity option provides a cost effective way to incorporate a variety of cartridge valves integral to the motor. The valve cavity is a standard 10 series 2-way cavity that accepts numerous cartridge valves, including over-running check valves, relief cartridges, flow control valves, pilot operated check fuses, and high pressure shuttle valves. Installation of a relief cartridge into the cavity provides an extra margin of safety for applications encountering frequent pressure spikes. Relief cartridges from 69 to 207 bar [1000 to 3000 psi] may also be factory installed.

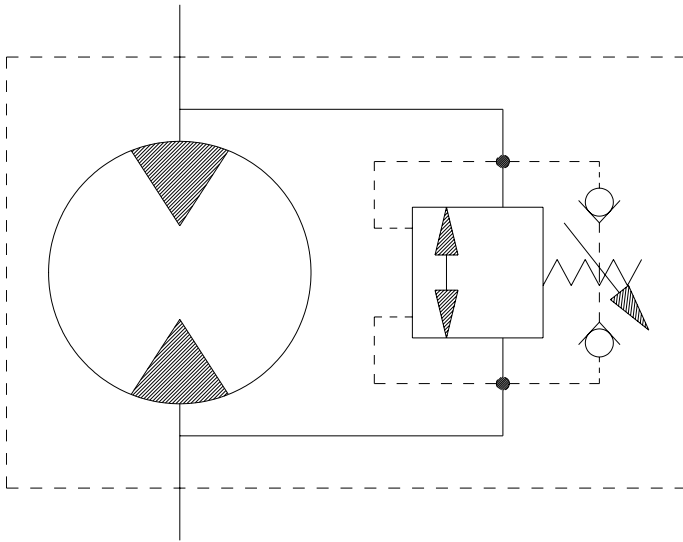

For basic systems with fixed displacement pumps, either manual or motorized flow control valves may be installed into the valve cavity to provide a simple method for controlling motor speed. It is also possible to incorporate the speed sensor option and a programmable logic controller with a motorized flow control valve to create a closed loop, fully automated speed control system. For motors with internal brakes, a shuttle valve cartridge may be installed into the cavity to provide a simple, fully integrated method for supplying release pressure to the pilot line to actuate an integral brake. To discuss other alternatives for the valve cavity option, contact an authorized Impro Fluidtek distributor.

## SLINGER SEAL

Slinger seals are available on select series offered by Impro Fluidtek. Slinger seals offer extended shaft/shaft seal protection by prevented a buildup of material around the circumference of the shaft which can lead to premature shaft seal failures. The Impro Fluidtek slinger seals are designed to be larger in diameter than competitive products, providing greater surface speed and 'slinging action'.

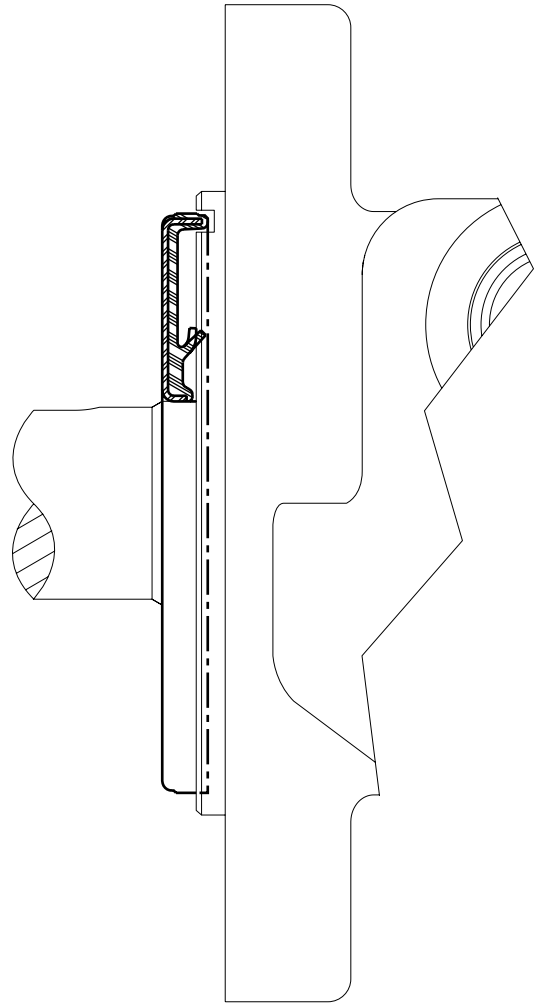

Slinger seals are also available on 4-hole flange mounts on select series. Contact a Impro Fluidtek Customer Service Representative for additional information.

**WS (365/366 Series)**  
Heavy Duty Hydraulic Motor

**OVERVIEW**

The WS targets agricultural equipment, skid steer attachments, and other applications that require greater torque under demanding conditions. A distinguishing feature of the WS in relation to competitive products is its heavy duty drive link with a larger pitch diameter. This enables the WS to better withstand pressure and torque spikes and is reflected in its intermittent and peak performance ratings.

Additional product features include a three zone commutator valve, heavy-duty tapered roller bearings, and case drain with integral internal drain.

**FEATURES / BENEFITS**

- Ten shaft and six mounting options to meet the most common SAE and European requirements.
- Heavy-duty tapered roller bearings for extra side load capacity.
- Heavy-duty drive link with larger pitch diameter than competitors for greater resistance to pressure and torque spikes.
- Three zone commutator valve for high flow capacity.
- Standard case drain with integral internal drain for extended shaft seal life.

**TYPICAL APPLICATIONS**

Heavy-duty wheel drives, sweepers, grain augers, spreaders, feed rollers, brush drives, mowers, harvesting equipment gear box mounts and more

**SERIES DESCRIPTIONS**

**365/366 - Hydraulic Motor**  
*Compact*

**365-366 - Hydraulic Motor**  
*Short Motor*

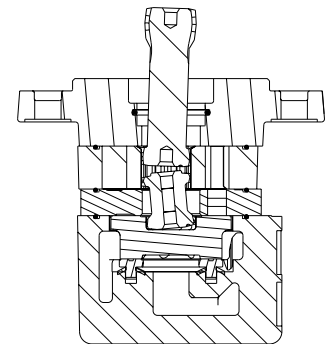
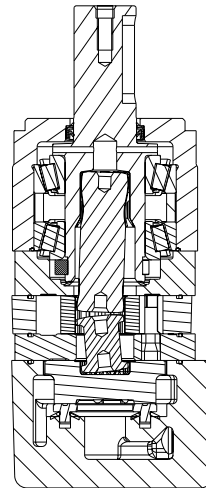

**SPECIFICATIONS**

CODE	Displacement cm <sup>3</sup> [in <sup>3</sup> /rev]	Max. Speed rpm		Max. Flow lpm [gpm]		Max. Torque Nm [lb-in]		Max. Pressure bar [psi]		
		cont.	inter.	cont.	inter.	cont.	inter.	cont.	inter.	peak
080	79 [4.8]	843	929	68 [18]	76 [20]	230 [2036]	305 [2699]	207 [3000]	276 [4000]	310 [4500]
100	100 [6.1]	756	945	76 [20]	95 [25]	270 [2390]	362 [3204]	207 [3000]	276 [4000]	310 [4500]
110	112 [6.8]	669	837	76 [20]	95 [25]	312 [2761]	418 [3699]	207 [3000]	276 [4000]	310 [4500]
130	129 [7.9]	588	734	76 [20]	95 [25]	370 [3328]	499 [4416]	207 [3000]	276 [4000]	310 [4500]
160	161 [9.8]	471	707	76 [20]	114 [30]	472 [4177]	627 [5549]	207 [3000]	276 [4000]	310 [4500]
200	201 [12.3]	377	566	76 [20]	114 [30]	579 [5124]	765 [6770]	207 [3000]	276 [4000]	310 [4500]
230	229 [14.0]	330	495	76 [20]	114 [30]	655 [5779]	872 [7717]	207 [3000]	276 [4000]	310 [4500]
250	248 [15.1]	305	459	76 [20]	114 [30]	657 [5814]	769 [6806]	190 [2750]	224 [3250]	259 [3750]
320	322 [19.6]	235	352	76 [20]	114 [30]	861 [7620]	1003 [8877]	190 [2750]	224 [3250]	259 [3750]
400	396 [24.2]	191	285	76 [20]	114 [30]	858 [7593]	1048 [9275]	155 [2250]	190 [2750]	224 [3250]
500	495 [30.2]	153	229	76 [20]	114 [30]	851 [7531]	1064 [9416]	121 [1750]	155 [2250]	172 [2500]

► Performance data is typical. Performance of production units varies slightly from one motor to another. Running at intermittent ratings should not exceed 10% of every minute of operation.

**DISPLACEMENT PERFORMANCE**

► Performance data is typical. Performance of production units varies slightly from one motor to another. Operating at maximum continuous pressure and maximum continuous flow simultaneously is not recommended. For additional information on product testing please refer to page 6.

		Pressure - bar [psi]								Max. Cont.	Max. Inter.	
<b>080</b>		17 [250]	35 [500]	69 [1000]	104 [1500]	138 [2000]	172 [2500]	207 [3000]	242 [3500]	276 [4000]		
79 cm <sup>3</sup> [4.8 in <sup>3</sup> ] / rev		Intermittent Ratings are below and to the right of the BOLD line. Intermittent Ratings - 10% of Operation										
Flow - lpm [gpm]	2 [0.5]	18 [159] <b>23</b>	38 [336] <b>22</b>	74 [655] <b>19</b>								25
	4 [1]	18 [159] <b>50</b>	40 [354] <b>47</b>	77 [682] <b>42</b>	115 [1018] <b>38</b>	150 [1328] <b>30</b>	182 [1611] <b>23</b>					51
	8 [2]	18 [159] <b>100</b>	39 [345] <b>96</b>	77 [682] <b>91</b>	117 [1036] <b>82</b>	154 [1363] <b>74</b>	192 [1699] <b>63</b>	224 [1983] <b>53</b>				101
	15 [4]	18 [159] <b>187</b>	39 [345] <b>182</b>	78 [690] <b>179</b>	118 [1044] <b>169</b>	156 [1381] <b>154</b>	194 [1717] <b>138</b>	230 [2036] <b>126</b>	260 [2301] <b>107</b>			190
	23 [6]	17 [150] <b>290</b>	37 [327] <b>282</b>	77 [682] <b>272</b>	116 [1027] <b>264</b>	155 [1372] <b>248</b>	192 [1699] <b>229</b>	223 [1974] <b>217</b>	264 [2337] <b>193</b>	302 [2673] <b>168</b>		291
	30 [8]	16 [142] <b>379</b>	36 [319] <b>369</b>	76 [673] <b>348</b>	117 [1036] <b>349</b>	155 [1372] <b>335</b>	194 [1717] <b>315</b>	224 [1983] <b>300</b>	266 [2354] <b>277</b>	304 [2691] <b>242</b>		380
	38 [10]	14 [124] <b>480</b>	34 [301] <b>468</b>	73 [646] <b>457</b>	114 [1009] <b>451</b>	153 [1354] <b>435</b>	191 [1690] <b>414</b>	230 [2036] <b>390</b>	265 [2345] <b>383</b>	305 [2699] <b>340</b>		481
	45 [12]	13 [115] <b>565</b>	33 [292] <b>556</b>	72 [637] <b>544</b>	113 [1000] <b>537</b>	152 [1345] <b>518</b>	190 [1682] <b>496</b>	223 [1974] <b>477</b>	265 [2345] <b>447</b>	304 [2691] <b>424</b>		570
	53 [14]		30 [266] <b>655</b>	69 [611] <b>642</b>	115 [1018] <b>630</b>	148 [1310] <b>616</b>	189 [1673] <b>585</b>	223 [1974] <b>572</b>	264 [2337] <b>545</b>	305 [2699] <b>519</b>		671
	61 [16]		26 [230] <b>752</b>	66 [584] <b>747</b>	103 [912] <b>736</b>	146 [1292] <b>705</b>	182 [1611] <b>678</b>	225 [1991] <b>650</b>	262 [2319] <b>644</b>	303 [2682] <b>600</b>		772
	68 [18]		26 [230] <b>843</b>	65 [575] <b>830</b>	106 [938] <b>825</b>	147 [1301] <b>798</b>	186 [1646] <b>769</b>	218 [1929] <b>768</b>	260 [2301] <b>753</b>	303 [2682] <b>682</b>		861
	76 [20]			61 [540] <b>929</b>	101 [894] <b>924</b>	140 [1239] <b>898</b>	174 [1540] <b>873</b>	214 [1894] <b>848</b>	258 [2283] <b>803</b>	302 [2673] <b>772</b>		962
	<b>Rotor Width</b>		Torque - Nm [lb-in], Speed rpm									
	15.7 [617]		Overall Efficiency - 70 - 100% <input type="checkbox"/> 40 - 69% <input type="checkbox"/> 0 - 39% <input type="checkbox"/>									
mm [in]		22 [192]	45 [394]	88 [778]	132 [1172]	176 [1556]	219 [1939]	264 [2334]	308 [2728]	351 [3111]		
		Theoretical Torque - Nm [lb-in] Displacement tested at 54°C [129°F] with an oil viscosity of 46cSt [213 SUS]										

		Pressure - bar [psi]								Max. Cont.	Max. Inter.	
<b>100</b>		17 [250]	35 [500]	69 [1000]	104 [1500]	138 [2000]	172 [2500]	207 [3000]	242 [3500]	276 [4000]		
100 cm <sup>3</sup> [6.1 in <sup>3</sup> ] / rev		Intermittent Ratings are below and to the right of the BOLD line. Intermittent Ratings - 10% of Operation										
Flow - lpm [gpm]	2 [0.5]	14 [124] <b>19</b>	38 [336] <b>19</b>	77 [681] <b>17</b>								20
	4 [1]	17 [150] <b>39</b>	42 [372] <b>39</b>	86 [761] <b>37</b>	130 [1151] <b>35</b>	169 [1496] <b>31</b>	205 [1814] <b>24</b>					40
	8 [2]	15 [133] <b>79</b>	43 [381] <b>78</b>	89 [788] <b>76</b>	135 [1195] <b>73</b>	179 [1584] <b>68</b>	220 [1947] <b>61</b>	259 [2292] <b>52</b>	290 [2567] <b>35</b>			80
	15 [4]	14 [124] <b>148</b>	43 [381] <b>148</b>	91 [805] <b>145</b>	136 [1204] <b>140</b>	181 [1602] <b>134</b>	224 [1982] <b>125</b>	267 [2363] <b>113</b>	308 [2726] <b>98</b>	341 [3018] <b>67</b>		150
	23 [6]	14 [124] <b>228</b>	43 [381] <b>228</b>	90 [797] <b>224</b>	137 [1212] <b>218</b>	182 [1611] <b>209</b>	226 [2000] <b>197</b>	270 [2390] <b>185</b>	314 [2779] <b>164</b>	354 [3133] <b>135</b>		230
	30 [8]	12 [106] <b>299</b>	41 [363] <b>298</b>	88 [779] <b>294</b>	136 [1204] <b>286</b>	181 [1602] <b>275</b>	225 [1991] <b>262</b>	270 [2390] <b>246</b>	314 [2779] <b>226</b>	356 [3151] <b>194</b>		300
	38 [10]	10 [89] <b>372</b>	38 [336] <b>372</b>	85 [752] <b>369</b>	132 [1168] <b>365</b>	178 [1575] <b>351</b>	223 [1974] <b>337</b>	269 [2381] <b>319</b>	315 [2788] <b>296</b>	360 [3186] <b>263</b>		380
	45 [12]		37 [327] <b>444</b>	84 [743] <b>435</b>	132 [1168] <b>434</b>	178 [1575] <b>419</b>	223 [1974] <b>403</b>	270 [2390] <b>384</b>	317 [2805] <b>361</b>	362 [3204] <b>325</b>		450
	53 [14]		35 [310] <b>525</b>	82 [726] <b>520</b>	129 [1142] <b>514</b>	176 [1558] <b>498</b>	221 [1956] <b>481</b>	269 [2381] <b>457</b>	317 [2805] <b>432</b>	363 [3213] <b>397</b>		530
	61 [16]		33 [292] <b>604</b>	79 [699] <b>600</b>	126 [1115] <b>592</b>	172 [1522] <b>576</b>	218 [1929] <b>558</b>	266 [2354] <b>533</b>	314 [2779] <b>503</b>	361 [3195] <b>474</b>		610
	68 [18]		31 [274] <b>675</b>	75 [664] <b>674</b>	123 [1089] <b>662</b>	169 [1496] <b>643</b>	216 [1912] <b>622</b>	263 [2328] <b>597</b>	313 [2770] <b>566</b>	360 [3186] <b>532</b>		680
	76 [20]		29 [257] <b>756</b>	71 [628] <b>754</b>	120 [1062] <b>742</b>	167 [1478] <b>723</b>	214 [1894] <b>700</b>	262 [2319] <b>673</b>	310 [2744] <b>640</b>	359 [3177] <b>600</b>		760
	83 [22]			69 [611] <b>825</b>	117 [1035] <b>813</b>	164 [1451] <b>794</b>	211 [1967] <b>769</b>	259 [2292] <b>743</b>	308 [2726] <b>708</b>	356 [3151] <b>669</b>		830
	91 [24]			65 [575] <b>905</b>	114 [1009] <b>893</b>	161 [1425] <b>875</b>	208 [1841] <b>853</b>	256 [2266] <b>823</b>	305 [2699] <b>781</b>	352 [3115] <b>749</b>		910
95 [25]			62 [549] <b>945</b>	111 [982] <b>931</b>	159 [1407] <b>908</b>	206 [1823] <b>882</b>	254 [2248] <b>854</b>	304 [2690] <b>805</b>	351 [3106] <b>750</b>		950	
<b>Rotor Width</b>		Torque - Nm [lb-in], Speed rpm										
19.7 [776]		Overall Efficiency - 70 - 100% <input type="checkbox"/> 40 - 69% <input type="checkbox"/> 0 - 39% <input type="checkbox"/>										
mm [in]		27 [239]	56 [493]	110 [972]	166 [1465]	220 [1944]	274 [2423]	329 [2916]	385 [3409]	439 [3888]		
		Theoretical Torque - Nm [lb-in] Displacement tested at 54°C [129°F] with an oil viscosity of 46cSt [213 SUS]										

**DISPLACEMENT PERFORMANCE**

► Performance data is typical. Performance of production units varies slightly from one motor to another. Operating at maximum continuous pressure and maximum continuous flow simultaneously is not recommended. For additional information on product testing please refer to page 6.

		Pressure - bar [psi]							Max. Cont.		Max. Inter.		
<b>110</b>		17 [250]	35 [500]	69 [1000]	104 [1500]	138 [2000]	172 [2500]	207 [3000]	242 [3500]	276 [4000]			
112 cm <sup>3</sup> [6.8 in <sup>3</sup> ] / rev		Intermittent Ratings are below and to the right of the <b>BOLD</b> line.										Intermittent Ratings - 10% of Operation	
Flow - lpm [gpm]	Max. Cont.	2 [0.5]	22 [195] 17	49 [434] 17	98 [867] 15								18
		4 [1]	23 [204] 35	51 [451] 35	102 [903] 34	149 [1319] 32	197 [1743] 29						36
		8 [2]	23 [204] 70	51 [451] 70	105 [929] 68	156 [1381] 66	204 [1805] 63	242 [2142] 56	281 [2487] 40	302 [2673] 24			71
		15 [4]	22 [195] 133	50 [443] 131	103 [912] 128	156 [1381] 123	207 [1832] 117	256 [2266] 107	304 [2690] 92	345 [3053] 73	371 [3283] 41		134
		23 [6]	22 [195] 203	48 [425] 202	101 [894] 198	156 [1381] 192	209 [1850] 184	261 [2310] 173	312 [2761] 159	361 [3195] 136	405 [3584] 106		205
		30 [8]	20 [177] 267	45 [398] 265	100 [885] 260	155 [1372] 252	208 [1841] 242	260 [2301] 231	312 [2761] 215	363 [3213] 192	412 [3646] 159		268
		38 [10]	19 [168] 337	42 [372] 336	95 [841] 330	153 [1354] 320	205 [1814] 308	258 [2283] 292	312 [2761] 278	363 [3213] 254	415 [3673] 224		339
		45 [12]	17 [150] 400	42 [372] 399	94 [832] 392	151 [1336] 383	204 [1805] 370	257 [2274] 355	312 [2761] 336	366 [3239] 313	418 [3699] 277		402
		53 [14]		38 [336] 470	93 [823] 463	148 [1310] 452	201 [1779] 437	254 [2248] 418	309 [2735] 399	364 [3221] 372	418 [3699] 338		473
		61 [16]		36 [319] 542	90 [797] 534	142 [1257] 524	198 [1752] 509	252 [2230] 489	308 [2726] 465	362 [3204] 438	417 [3690] 407		545
		68 [18]		32 [283] 606	87 [770] 598	143 [1266] 586	195 [1726] 571	249 [2204] 549	305 [2699] 525	360 [3186] 497	415 [3673] 461		607
		76 [20]		28 [248] 669	82 [726] 668	138 [1221] 656	191 [1690] 641	245 [2168] 618	300 [2655] 593	357 [3159] 560	412 [3646] 521		679
83 [22]			78 [690] 731	134 [1186] 719	185 [1637] 702	239 [2115] 679	296 [2620] 652	352 [3115] 621	408 [3611] 576		741		
91 [24]			72 [637] 803	127 [1124] 790	181 [1602] 771	235 [2080] 747	291 [2575] 721	349 [3089] 683	406 [3593] 635		813		
95 [25]			70 [620] 837	125 [1106] 821	179 [1584] 801	233 [2062] 780	289 [2558] 751	346 [3062] 714	403 [3567] 668		848		
<b>Rotor Width</b>		Torque - Nm [lb-in], Speed rpm										Overall Efficiency - 70 - 100% <input type="checkbox"/> 40 - 69% <input type="checkbox"/> 0 - 39% <input type="checkbox"/>	
22.1 [0.871] mm [in]		30 [268]	62 [552]	123 [1089]	185 [1641]	246 [2177]	307 [2713]	369 [3266]	431 [3181]	492 [4354]			
		Theoretical Torque - Nm [lb-in]										Displacement tested at 54°C [129°F] with an oil viscosity of 46cSt [213 SUS]	

		Pressure - bar [psi]							Max. Cont.		Max. Inter.		
<b>130</b>		17 [250]	35 [500]	69 [1000]	104 [1500]	138 [2000]	172 [2500]	207 [3000]	242 [3500]	276 [4000]			
129 cm <sup>3</sup> [7.9 in <sup>3</sup> ] / rev		Intermittent Ratings are below and to the right of the <b>BOLD</b> line.										Intermittent Ratings - 10% of Operation	
Flow - lpm [gpm]	Max. Cont.	2 [0.5]	23 [204] 15	53 [469] 15									16
		4 [1]	24 [212] 30	55 [487] 30	113 [1000] 30	167 [1478] 29	225 [1991] 27						31
		8 [2]	25 [221] 61	57 [504] 61	119 [1053] 60	179 [1584] 58	234 [2071] 54	290 [2567] 46	331 [2929] 29				62
		15 [4]	26 [230] 115	58 [513] 115	122 [1080] 113	186 [1646] 109	247 [2186] 103	306 [2708] 93	363 [3213] 77	416 [3682] 55			116
		23 [6]	25 [221] 177	57 [504] 177	122 [1080] 174	187 [1655] 169	250 [2213] 161	312 [2761] 147	373 [3301] 130	431 [3814] 105	483 [4275] 70		178
		30 [8]	23 [204] 232	57 [504] 232	120 [1062] 228	186 [1646] 222	250 [2213] 212	313 [2770] 197	376 [3328] 179	437 [3867] 156	494 [4372] 125		233
		38 [10]	22 [195] 294	54 [478] 294	118 [1044] 290	184 [1628] 283	248 [2195] 273	312 [2761] 257	376 [3328] 237	439 [3885] 212	499 [4416] 182		295
		45 [12]	20 [177] 348	53 [469] 348	116 [1027] 343	183 [1620] 334	246 [2177] 321	310 [2744] 304	375 [3319] 282	439 [3885] 255	499 [4416] 221		349
		53 [14]		49 [434] 410	113 [1000] 405	179 [1584] 395	243 [2151] 380	307 [2717] 361	373 [3301] 336	437 [3867] 311	499 [4416] 275		411
		61 [16]		46 [407] 472	110 [974] 467	176 [1558] 456	240 [2124] 439	304 [2690] 417	370 [3275] 392	435 [3850] 364	497 [4398] 328		473
		68 [18]		42 [372] 526	106 [938] 521	172 [1522] 510	236 [2089] 493	300 [2655] 470	366 [3239] 442	432 [3823] 411	495 [4381] 376		527
		76 [20]		38 [336] 588	102 [903] 583	167 [1478] 572	232 [2053] 553	297 [2628] 527	363 [3213] 499	428 [3788] 467	491 [4345] 423		589
83 [22]		33 [292] 642	98 [867] 638	164 [1451] 627	228 [2018] 607	293 [2593] 581	359 [3177] 549	423 [3744] 517	485 [4292] 473		643		
91 [24]		30 [266] 704	93 [823] 702	158 [1398] 692	222 [1965] 677	288 [2549] 648	354 [3133] 625	421 [3726] 576	483 [4275] 531		705		
95 [25]		27 [239] 734	91 [805] 733	158 [1398] 720	220 [1947] 703	286 [2531] 672	351 [3106] 639	419 [3708] 602	483 [4275] 559		736		
<b>Rotor Width</b>		Torque - Nm [lb-in], Speed rpm										Overall Efficiency - 70 - 100% <input type="checkbox"/> 40 - 69% <input type="checkbox"/> 0 - 39% <input type="checkbox"/>	
25.4 [1.000] mm [in]		35 [309]	72 [636]	142 [1254]	214 [1890]	283 [2508]	353 [3125]	425 [3761]	497 [4397]	567 [5015]			
		Theoretical Torque - Nm [lb-in]										Displacement tested at 54°C [129°F] with an oil viscosity of 46cSt [213 SUS]	

**DISPLACEMENT PERFORMANCE**

► Performance data is typical. Performance of production units varies slightly from one motor to another. Operating at maximum continuous pressure and maximum continuous flow simultaneously is not recommended. For additional information on product testing please refer to page 6.

		Pressure - bar [psi]								Max. Cont.	Max. Inter.	
<b>160</b>		17 [250]	35 [500]	69 [1000]	104 [1500]	138 [2000]	172 [2500]	207 [3000]	242 [3500]	276 [4000]		
161 cm <sup>3</sup> [9.8 in <sup>3</sup> ] / rev		<b>Intermittent Ratings are below and to the right of the BOLD line.</b>								<b>Intermittent Ratings - 10% of Operation</b>		
Flow - lpm [gpm]	Max. Cont.	2 [0.5]	21 [186] <b>11</b>	65 [575] <b>10</b>								12
		4 [1]	29 [257] <b>24</b>	67 [593] <b>24</b>	140 [1239] <b>23</b>	209 [1850] <b>21</b>						25
		8 [2]	31 [274] <b>49</b>	71 [628] <b>48</b>	143 [1266] <b>47</b>	214 [1894] <b>46</b>	285 [2522] <b>43</b>	352 [3115] <b>36</b>				50
		15 [4]	34 [301] <b>92</b>	75 [664] <b>92</b>	154 [1363] <b>91</b>	231 [2044] <b>88</b>	306 [2708] <b>84</b>	380 [3363] <b>77</b>	454 [4018] <b>64</b>	519 [4593] <b>43</b>		93
		23 [6]	32 [283] <b>142</b>	75 [664] <b>141</b>	155 [1372] <b>140</b>	235 [2080] <b>139</b>	314 [2779] <b>133</b>	390 [3452] <b>123</b>	466 [4124] <b>108</b>	537 [4752] <b>85</b>	604 [5345] <b>52</b>	143
		30 [8]	31 [274] <b>185</b>	73 [646] <b>185</b>	154 [1363] <b>184</b>	234 [2071] <b>183</b>	315 [2788] <b>178</b>	394 [3487] <b>166</b>	472 [4177] <b>151</b>	547 [4841] <b>130</b>	615 [5443] <b>99</b>	186
		38 [10]	28 [248] <b>233</b>	72 [637] <b>231</b>	153 [1354] <b>229</b>	231 [2044] <b>229</b>	311 [2752] <b>223</b>	391 [3460] <b>210</b>	471 [4168] <b>194</b>	548 [4850] <b>175</b>	620 [5487] <b>144</b>	236
		45 [12]	25 [221] <b>280</b>	67 [593] <b>280</b>	151 [1336] <b>272</b>	229 [2027] <b>269</b>	310 [2744] <b>260</b>	391 [3460] <b>243</b>	466 [4124] <b>227</b>	544 [4814] <b>202</b>	624 [5522] <b>159</b>	280
		53 [14]	23 [204] <b>328</b>	63 [558] <b>327</b>	145 [1283] <b>320</b>	227 [2009] <b>312</b>	307 [2717] <b>303</b>	388 [3434] <b>288</b>	467 [4133] <b>271</b>	548 [4850] <b>247</b>	622 [5505] <b>216</b>	329
		61 [16]		58 [513] <b>378</b>	139 [1230] <b>372</b>	221 [1956] <b>366</b>	302 [2673] <b>361</b>	386 [3416] <b>350</b>	468 [4142] <b>328</b>	549 [4859] <b>305</b>	626 [5540] <b>273</b>	379
		68 [18]		53 [469] <b>418</b>	135 [1195] <b>412</b>	217 [1920] <b>410</b>	298 [2637] <b>406</b>	380 [3363] <b>389</b>	468 [4142] <b>370</b>	549 [4859] <b>348</b>	627 [5549] <b>312</b>	422
		76 [20]		53 [469] <b>471</b>	133 [1177] <b>467</b>	216 [1912] <b>455</b>	296 [2620] <b>440</b>	377 [3336] <b>423</b>	461 [4080] <b>397</b>	544 [4814] <b>368</b>	609 [5390] <b>348</b>	472
		83 [22]		44 [389] <b>515</b>	126 [1115] <b>514</b>	205 [1814] <b>513</b>	282 [2496] <b>504</b>	359 [3177] <b>491</b>	440 [3894] <b>467</b>	523 [4629] <b>434</b>	602 [5328] <b>384</b>	516
		91 [24]		38 [336] <b>560</b>	119 [1053] <b>556</b>	207 [1832] <b>547</b>	284 [2513] <b>546</b>	368 [3257] <b>532</b>	440 [3894] <b>515</b>	521 [4611] <b>493</b>	606 [5363] <b>461</b>	565
95 [25]		34 [301] <b>585</b>	112 [991] <b>580</b>	194 [1717] <b>579</b>	276 [2443] <b>574</b>	365 [3230] <b>555</b>	445 [3938] <b>540</b>			590		
114 [30]			94 [832] <b>707</b>	177 [1566] <b>706</b>	269 [2381] <b>687</b>	341 [3018] <b>676</b>	418 [3699] <b>654</b>			708		
<b>Rotor Width</b>		Torque - Nm [lb-in], Speed rpm										
31.8 [1.251]		Overall Efficiency - 70 - 100% <input type="checkbox"/> 40 - 69% <input type="checkbox"/> 0 - 39% <input type="checkbox"/>										
mm [in]		44 [386]	90 [794]	177 [1565]	266 [2358]	354 [3130]	441 [3901]	530 [4694]	620 [5488]	707 [6259]		
		Theoretical Torque - Nm [lb-in] Displacement tested at 54°C [129°F] with an oil viscosity of 46cSt [213 SUS]										

		Pressure - bar [psi]								Max. Cont.	Max. Inter.		
<b>200</b>		17 [250]	35 [500]	69 [1000]	104 [1500]	138 [2000]	172 [2500]	190 [2750]	207 [3000]	242 [3500]	276 [4000]		
201 cm <sup>3</sup> [12.3 in <sup>3</sup> ] / rev		<b>Intermittent Ratings are below and to the right of the BOLD line.</b>								<b>Intermittent Ratings - 10% of Operation</b>			
Flow - lpm [gpm]	Max. Cont.	4 [1]	40 [354] <b>19</b>	87 [770] <b>18</b>	189 [1673] <b>17</b>	282 [2496] <b>15</b>						20	
		8 [2]	44 [389] <b>39</b>	97 [858] <b>39</b>	192 [1699] <b>38</b>	286 [2531] <b>37</b>	370 [3275] <b>36</b>	456 [4036] <b>33</b>				40	
		15 [4]	45 [398] <b>74</b>	99 [876] <b>74</b>	198 [1752] <b>73</b>	298 [2637] <b>71</b>	391 [3460] <b>67</b>	481 [4257] <b>63</b>	526 [4655] <b>60</b>	566 [5009] <b>57</b>	645 [5708] <b>50</b>	75	
		23 [6]	42 [372] <b>113</b>	97 [858] <b>113</b>	196 [1735] <b>112</b>	296 [2620] <b>108</b>	389 [3443] <b>104</b>	478 [4230] <b>98</b>	523 [4629] <b>93</b>	568 [5027] <b>93</b>	653 [5779] <b>80</b>	724 [6407] <b>66</b>	114
		30 [8]	40 [354] <b>148</b>	94 [832] <b>147</b>	194 [1717] <b>146</b>	293 [2593] <b>142</b>	388 [3434] <b>136</b>	478 [4230] <b>129</b>	525 [4646] <b>125</b>	568 [5027] <b>121</b>	658 [5823] <b>109</b>	724 [6407] <b>96</b>	149
		38 [10]	36 [319] <b>188</b>	91 [805] <b>187</b>	191 [1690] <b>186</b>	292 [2584] <b>181</b>	388 [3434] <b>175</b>	483 [4275] <b>167</b>	533 [4717] <b>162</b>	579 [5124] <b>158</b>	672 [5947] <b>146</b>	759 [6717] <b>126</b>	189
		45 [12]	32 [283] <b>223</b>	87 [770] <b>222</b>	186 [1646] <b>221</b>	288 [2549] <b>217</b>	386 [3416] <b>208</b>	482 [4266] <b>198</b>	532 [4708] <b>194</b>	579 [5124] <b>188</b>	675 [5974] <b>175</b>	765 [6770] <b>162</b>	224
		53 [14]	30 [266] <b>263</b>	81 [717] <b>262</b>	181 [1602] <b>261</b>	283 [2505] <b>257</b>	382 [3381] <b>248</b>	479 [4239] <b>236</b>	528 [4673] <b>235</b>	576 [5098] <b>224</b>	673 [5956] <b>212</b>	765 [6770] <b>194</b>	264
		61 [16]	27 [239] <b>302</b>	72 [637] <b>301</b>	172 [1522] <b>299</b>	276 [2443] <b>297</b>	375 [3319] <b>288</b>	473 [4186] <b>276</b>	524 [4637] <b>269</b>	571 [5053] <b>263</b>	667 [5903] <b>248</b>	761 [6735] <b>231</b>	303
		68 [18]		66 [584] <b>337</b>	167 [1478] <b>336</b>	269 [2381] <b>332</b>	368 [3257] <b>324</b>	466 [4124] <b>312</b>	518 [4584] <b>303</b>	566 [5009] <b>297</b>	664 [5876] <b>279</b>	757 [6699] <b>262</b>	338
		76 [20]		58 [513] <b>377</b>	157 [1389] <b>375</b>	260 [2301] <b>372</b>	359 [3177] <b>364</b>	457 [4044] <b>353</b>	510 [4514] <b>343</b>	559 [4947] <b>336</b>	656 [5806] <b>320</b>	751 [6646] <b>302</b>	378
		83 [22]		50 [443] <b>412</b>	153 [1354] <b>410</b>	251 [2221] <b>408</b>	352 [3115] <b>398</b>	449 [3974] <b>387</b>	503 [4452] <b>377</b>	550 [4868] <b>372</b>			413
		91 [24]		41 [363] <b>452</b>	145 [1283] <b>450</b>	244 [2159] <b>448</b>	346 [3062] <b>436</b>	445 [3938] <b>421</b>	496 [4390] <b>415</b>	538 [4761] <b>410</b>			453
		95 [25]			139 [1230] <b>472</b>	239 [2115] <b>466</b>	339 [3000] <b>456</b>	438 [3876] <b>441</b>	491 [4345] <b>430</b>	539 [4770] <b>423</b>			473
114 [30]			116 [1027] <b>566</b>	213 [1885] <b>561</b>	313 [2770] <b>549</b>	416 [3682] <b>531</b>	468 [4142] <b>521</b>	512 [4531] <b>519</b>			567		
<b>Rotor Width</b>		Torque - Nm [lb-in], Speed rpm											
39.4 [1.552]		Overall Efficiency - 70 - 100% <input type="checkbox"/> 40 - 69% <input type="checkbox"/> 0 - 39% <input type="checkbox"/>											
mm [in]		54 [481]	112 [991]	221 [1954]	333 [2944]	441 [3907]	550 [4870]	608 [5379]	662 [5861]	774 [6852]	883 [7814]		
		Theoretical Torque - Nm [lb-in] Displacement tested at 54°C [129°F] with an oil viscosity of 46cSt [213 SUS]											

# WS (365/366 Series)

## Heavy Duty Hydraulic Motor



### DISPLACEMENT PERFORMANCE

► Performance data is typical. Performance of production units varies slightly from one motor to another. Operating at maximum continuous pressure and maximum continuous flow simultaneously is not recommended. For additional information on product testing please refer to page 6.

		Pressure - bar [psi]										Max. Cont.		Max. Inter.			
<b>230</b>		17 [250]	35 [500]	69 [1000]	104 [1500]	138 [2000]	172 [2500]	190 [2750]	207 [3000]	242 [3500]	276 [4000]						
229 cm <sup>3</sup> [14.0 in <sup>3</sup> ] / rev		Intermittent Ratings are below and to the right of the BOLD line.										Intermittent Ratings - 10% of Operation					
Flow - lpm [gpm]	Max. Cont.	4 [1]	50 [443] <b>16</b>	98 [867] <b>15</b>	198 [1752] <b>14</b>	310 [2744] <b>13</b>									17		
		8 [2]	42 [372] <b>34</b>	99 [876] <b>34</b>	204 [1805] <b>34</b>	316 [2797] <b>33</b>	416 [3682] <b>32</b>	510 [4514] <b>28</b>	552 [4885] <b>25</b>	594 [5257] <b>22</b>					35		
		15 [4]	47 [416] <b>65</b>	104 [920] <b>64</b>	214 [1894] <b>63</b>	325 [2876] <b>62</b>	426 [3770] <b>58</b>	526 [4655] <b>55</b>	580 [5133] <b>51</b>	626 [5540] <b>47</b>	721 [6381] <b>37</b>			66			
		23 [6]	45 [398] <b>99</b>	105 [929] <b>99</b>	218 [1929] <b>98</b>	331 [2929] <b>96</b>	438 [3876] <b>93</b>	544 [4814] <b>87</b>	598 [5292] <b>83</b>	649 [5744] <b>79</b>	752 [6655] <b>67</b>	843 [7461] <b>50</b>		100			
		30 [8]	43 [381] <b>130</b>	103 [912] <b>129</b>	217 [1920] <b>127</b>	332 [2938] <b>125</b>	441 [3903] <b>121</b>	549 [4859] <b>116</b>	602 [5328] <b>111</b>	654 [5788] <b>106</b>	758 [6708] <b>39</b>	859 [7602] <b>76</b>		131			
		38 [10]	40 [354] <b>165</b>	100 [885] <b>164</b>	214 [1894] <b>162</b>	330 [2921] <b>159</b>	440 [3894] <b>154</b>	548 [4850] <b>148</b>	604 [5345] <b>144</b>	655 [5797] <b>138</b>	761 [6735] <b>123</b>	866 [7664] <b>105</b>		166			
		45 [12]	35 [310] <b>196</b>	95 [841] <b>194</b>	211 [1867] <b>192</b>	328 [2903] <b>189</b>	438 [3876] <b>184</b>	546 [4832] <b>177</b>	604 [5345] <b>172</b>	656 [5806] <b>167</b>	764 [6761] <b>152</b>	869 [7691] <b>130</b>		197			
		53 [14]	30 [266] <b>230</b>	90 [797] <b>230</b>	206 [1823] <b>227</b>	323 [2859] <b>223</b>	435 [3850] <b>217</b>	544 [4814] <b>210</b>	601 [5319] <b>204</b>	654 [5788] <b>197</b>	763 [6753] <b>183</b>	871 [7708] <b>113</b>		231			
		61 [16]	28 [248] <b>265</b>	84 [743] <b>265</b>	200 [1770] <b>262</b>	317 [2805] <b>257</b>	430 [3806] <b>251</b>	540 [4779] <b>243</b>	598 [5292] <b>237</b>	652 [5770] <b>231</b>	763 [6753] <b>216</b>	872 [7717] <b>192</b>		266			
		68 [18]		77 [681] <b>295</b>	191 [1690] <b>292</b>	311 [2752] <b>288</b>	425 [3761] <b>281</b>	536 [4744] <b>272</b>	593 [5248] <b>266</b>	648 [5735] <b>260</b>	759 [6717] <b>244</b>	869 [7691] <b>222</b>		297			
		76 [20]		68 [602] <b>330</b>	184 [1628] <b>327</b>	302 [2673] <b>323</b>	416 [3682] <b>316</b>	529 [4682] <b>306</b>	586 [5186] <b>300</b>	642 [5682] <b>294</b>				332			
		83 [22]		58 [513] <b>361</b>	176 [1558] <b>358</b>	295 [2611] <b>353</b>	410 [3629] <b>346</b>	523 [4629] <b>329</b>	580 [5133] <b>323</b>	636 [5629] <b>323</b>				362			
		91 [24]		51 [451] <b>396</b>	167 [1478] <b>393</b>	285 [2522] <b>388</b>	400 [3540] <b>380</b>	513 [4531] <b>370</b>	571 [5053] <b>363</b>	627 [5549] <b>357</b>				397			
		95 [25]			164 [1451] <b>411</b>	250 [2478] <b>406</b>	395 [3496] <b>399</b>	507 [4487] <b>389</b>	564 [4991] <b>382</b>	622 [5505] <b>375</b>				415			
		114 [30]			130 [1151] <b>495</b>	253 [2239] <b>489</b>	368 [3257] <b>480</b>	483 [4275] <b>467</b>	541 [4788] <b>460</b>	594 [5257] <b>452</b>				498			
Rotor Width		Torque - Nm [lb-in], Speed rpm										Overall Efficiency - 70 - 100%		40 - 69%		0 - 39%	
45.5 [1.791] mm [in]		62 [548]	128 [1129]	251 [2226]	379 [3355]	503 [4451]	627 [5548]	693 [6129]	754 [6677]	882 [7806]	1006 [8903]						
		Theoretical Torque - Nm [lb-in]										Displacement tested at 54°C [129°F] with an oil viscosity of 46cSt [213 SUS]					

		Pressure - bar [psi]										Max. Cont.		Max. Inter.			
<b>250</b>		17 [250]	35 [500]	69 [1000]	104 [1500]	138 [2000]	155 [2250]	172 [2500]	190 [2750]	207 [3000]	224 [3250]						
248 cm <sup>3</sup> [15.1 in <sup>3</sup> ] / rev		Intermittent Ratings are below and to the right of the BOLD line.										Intermittent Ratings - 10% of Operation					
Flow - lpm [gpm]	Max. Cont.	4 [1]	51 [481] <b>15</b>	112 [991] <b>15</b>	230 [2036] <b>14</b>										16		
		8 [2]	53 [469] <b>31</b>	118 [1044] <b>31</b>	236 [2089] <b>30</b>	355 [3142] <b>28</b>	464 [4106] <b>23</b>	522 [4620] <b>19</b>	575 [5089] <b>15</b>						32		
		15 [4]	50 [443] <b>59</b>	119 [1053] <b>59</b>	239 [2115] <b>58</b>	361 [3195] <b>54</b>	476 [4213] <b>46</b>	531 [4699] <b>42</b>	586 [5186] <b>37</b>	644 [5699] <b>31</b>	696 [6160] <b>26</b>	740 [6549] <b>22</b>		60			
		23 [6]	50 [443] <b>92</b>	115 [1018] <b>92</b>	237 [2097] <b>90</b>	360 [3186] <b>83</b>	476 [4213] <b>74</b>	525 [4646] <b>70</b>	585 [5177] <b>64</b>	640 [5664] <b>58</b>	697 [6168] <b>52</b>	751 [6646] <b>47</b>		93			
		30 [8]	47 [416] <b>120</b>	111 [982] <b>120</b>	234 [2071] <b>117</b>	357 [3159] <b>110</b>	475 [4204] <b>101</b>	531 [4699] <b>93</b>	598 [5292] <b>87</b>	657 [5814] <b>78</b>	712 [6301] <b>72</b>	759 [6717] <b>71</b>		121			
		38 [10]	42 [372] <b>152</b>	108 [956] <b>151</b>	231 [2044] <b>150</b>	355 [3142] <b>144</b>	475 [4204] <b>131</b>	533 [4717] <b>126</b>	591 [5230] <b>119</b>	654 [5788] <b>108</b>	707 [6257] <b>105</b>	769 [6806] <b>90</b>		153			
		45 [12]	35 [310] <b>180</b>	102 [903] <b>180</b>	225 [1991] <b>179</b>	351 [3106] <b>172</b>	469 [4151] <b>162</b>	528 [4673] <b>155</b>	585 [5177] <b>147</b>	647 [5726] <b>138</b>	704 [6230] <b>130</b>	755 [6682] <b>119</b>		181			
		53 [14]	32 [283] <b>213</b>	92 [814] <b>212</b>	216 [1912] <b>212</b>	342 [3027] <b>205</b>	462 [4089] <b>193</b>	521 [4611] <b>187</b>	580 [5133] <b>181</b>	641 [5673] <b>170</b>	698 [6177] <b>163</b>	754 [6673] <b>152</b>		214			
		61 [16]	29 [257] <b>245</b>	83 [735] <b>244</b>	210 [1859] <b>244</b>	333 [2947] <b>238</b>	454 [4018] <b>226</b>	512 [4531] <b>221</b>	571 [5053] <b>213</b>	633 [5602] <b>203</b>	691 [6115] <b>196</b>	746 [6602] <b>184</b>		246			
		68 [18]	27 [239] <b>273</b>	73 [646] <b>272</b>	200 [1770] <b>271</b>	323 [2859] <b>267</b>	445 [3938] <b>256</b>	504 [4460] <b>249</b>	563 [4983] <b>240</b>	623 [5514] <b>231</b>				274			
		76 [20]		63 [558] <b>305</b>	188 [1664] <b>303</b>	310 [2744] <b>301</b>	433 [3832] <b>289</b>	494 [4372] <b>283</b>	552 [4885] <b>273</b>	613 [5425] <b>267</b>				306			
		83 [22]		57 [504] <b>334</b>	179 [1584] <b>334</b>	302 [2673] <b>328</b>	425 [3761] <b>314</b>	484 [4283] <b>307</b>	545 [4823] <b>297</b>	608 [5381] <b>286</b>				335			
		91 [24]		41 [363] <b>366</b>	171 [1513] <b>364</b>	291 [2575] <b>358</b>	413 [3655] <b>343</b>	476 [4213] <b>334</b>	534 [4726] <b>327</b>	596 [5275] <b>316</b>				367			
		95 [25]		32 [283] <b>382</b>	160 [1416] <b>381</b>	280 [2478] <b>381</b>	401 [3549] <b>368</b>	463 [4098] <b>359</b>	524 [4637] <b>348</b>	584 [5168] <b>341</b>				383			
		114 [30]			128 [1133] <b>459</b>	246 [2177] <b>456</b>	372 [3292] <b>442</b>	431 [3814] <b>434</b>	494 [4372] <b>422</b>	554 [4903] <b>412</b>				460			
Rotor Width		Torque - Nm [lb-in], Speed rpm										Overall Efficiency - 70 - 100%		40 - 69%		0 - 39%	
39.4 [1.552] mm [in]		67 [594]	138 [1223]	272 [2410]	411 [3633]	545 [4821]	612 [5415]	679 [6008]	750 [6637]	817 [7231]	884 [7825]						
		Theoretical Torque - Nm [lb-in]										Displacement tested at 54°C [129°F] with an oil viscosity of 46cSt [213 SUS]					

**DISPLACEMENT PERFORMANCE**

► Performance data is typical. Performance of production units varies slightly from one motor to another. Operating at maximum continuous pressure and maximum continuous flow simultaneously is not recommended. For additional information on product testing please refer to page 6.

		Pressure - bar [psi]									Max. Cont.	Max. Inter.	
<b>320</b>		17 [250]	35 [500]	69 [1000]	104 [1500]	138 [2000]	155 [2250]	172 [2500]	190 [2750]	207 [3000]	224 [3250]		
322 cm <sup>3</sup> [19.6 in <sup>3</sup> ] / rev		<b>Intermittent Ratings are below and to the right of the BOLD line.</b>						<b>Intermittent Ratings - 10% of Operation</b>					
Flow - lpm [gpm]	4 [1]	68 [602] <b>11</b>	145 [1283] <b>9</b>									12	
	8 [2]	77 [681] <b>24</b>	156 [1381] <b>24</b>	311 [2752] <b>23</b>	455 [4027] <b>21</b>	590 [5222] <b>20</b>	640 [5664] <b>19</b>					25	
	15 [4]	77 [681] <b>46</b>	160 [1416] <b>45</b>	311 [2752] <b>43</b>	458 [4053] <b>40</b>	594 [5257] <b>36</b>	655 [5797] <b>32</b>	705 [6239] <b>28</b>	770 [6815] <b>24</b>	835 [7390] <b>18</b>		47	
	23 [6]	73 [646] <b>70</b>	157 [1389] <b>69</b>	316 [2797] <b>68</b>	478 [4230] <b>64</b>	628 [5558] <b>57</b>	698 [6177] <b>53</b>	768 [6797] <b>48</b>	841 [7443] <b>43</b>	910 [8054] <b>38</b>	975 [8629] <b>30</b>	71	
	30 [8]	69 [611] <b>92</b>	154 [1363] <b>90</b>	316 [2797] <b>87</b>	479 [4239] <b>83</b>	631 [5584] <b>77</b>	705 [6239] <b>73</b>	780 [6903] <b>68</b>	860 [7611] <b>63</b>	929 [8222] <b>57</b>	998 [8832] <b>49</b>	93	
	38 [10]	64 [566] <b>116</b>	150 [1328] <b>114</b>	311 [2752] <b>111</b>	480 [4248] <b>106</b>	631 [5584] <b>100</b>	709 [6275] <b>96</b>	784 [6938] <b>90</b>	861 [7620] <b>83</b>	930 [8231] <b>79</b>	1000 [8850] <b>72</b>	118	
	45 [12]	59 [522] <b>138</b>	143 [1266] <b>136</b>	305 [2699] <b>133</b>	471 [4168] <b>127</b>	632 [5593] <b>119</b>	705 [6239] <b>115</b>	783 [6930] <b>110</b>	860 [7611] <b>105</b>	934 [8266] <b>98</b>	1000 [8850] <b>86</b>	140	
	53 [14]	49 [434] <b>162</b>	137 [1212] <b>160</b>	297 [2628] <b>157</b>	463 [4098] <b>151</b>	627 [5549] <b>142</b>	697 [6168] <b>138</b>	778 [6885] <b>132</b>	858 [7593] <b>126</b>	937 [8292] <b>120</b>	1003 [8877] <b>113</b>	165	
	61 [16]	41 [363] <b>187</b>	128 [1133] <b>185</b>	288 [2549] <b>182</b>	457 [4044] <b>175</b>	616 [5452] <b>167</b>	689 [6098] <b>161</b>	769 [6806] <b>156</b>	847 [7496] <b>150</b>			189	
	68 [18]	35 [310] <b>210</b>	120 [1062] <b>208</b>	282 [2496] <b>201</b>	452 [4000] <b>192</b>	609 [5390] <b>182</b>	683 [6045] <b>176</b>	762 [6744] <b>170</b>	841 [7443] <b>163</b>			211	
	76 [20]	26 [230] <b>235</b>	113 [1000] <b>230</b>	273 [2416] <b>225</b>	443 [3921] <b>216</b>	603 [5337] <b>203</b>	664 [5876] <b>199</b>	744 [6584] <b>192</b>	830 [7346] <b>184</b>			236	
	83 [22]		99 [876] <b>256</b>	262 [2319] <b>247</b>	430 [3806] <b>240</b>	590 [5222] <b>225</b>	660 [5841] <b>219</b>	741 [6558] <b>212</b>	820 [7257] <b>202</b>			258	
	91 [24]		85 [752] <b>282</b>	246 [2177] <b>273</b>	415 [3673] <b>267</b>	576 [5098] <b>249</b>	654 [5788] <b>242</b>	731 [6469] <b>233</b>	810 [7169] <b>225</b>			283	
	95 [25]		76 [673] <b>294</b>	241 [2133] <b>286</b>	404 [3575] <b>281</b>	571 [5053] <b>261</b>	648 [5735] <b>254</b>	719 [6363] <b>246</b>	804 [7115] <b>236</b>			295	
114 [30]		44 [389] <b>352</b>	204 [1805] <b>345</b>	371 [3283] <b>337</b>	538 [4761] <b>321</b>	602 [5328] <b>314</b>	685 [6062] <b>304</b>	766 [6779] <b>293</b>			354		
<b>Rotor Width</b>		Torque - Nm [lb-in], Speed rpm										Overall Efficiency - 70 - 100% <input type="checkbox"/> 40 - 69% <input type="checkbox"/> 0 - 39% <input type="checkbox"/>	
63.5 [2.501] mm [in]		87 [771]	179 [1587]	354 [3130]	533 [4717]	707 [6259]	794 [7030]	881 [7801]	974 [8618]	1061 [9389]	1148 [10160]		
		Theoretical Torque - Nm [lb-in]					Displacement tested at 54°C [129°F] with an oil viscosity of 46cSt [213 SUS]						

		Pressure - bar [psi]									Max. Cont.	Max. Inter.	
<b>400</b>		17 [250]	35 [500]	69 [1000]	86 [1250]	104 [1500]	121 [1750]	138 [2000]	155 [2250]	172 [2500]	190 [2750]		
396 cm <sup>3</sup> [24.2 in <sup>3</sup> ] / rev		<b>Intermittent Ratings are below and to the right of the BOLD line.</b>						<b>Intermittent Ratings - 10% of Operation</b>					
Flow - lpm [gpm]	4 [1]	78 [690] <b>9</b>	180 [1593] <b>8</b>									10	
	8 [2]	84 [743] <b>19</b>	185 [1637] <b>18</b>	380 [3363] <b>18</b>	460 [4071] <b>18</b>	555 [4912] <b>17</b>	640 [5664] <b>15</b>					20	
	15 [4]	84 [743] <b>37</b>	185 [1637] <b>36</b>	374 [3310] <b>36</b>	468 [4142] <b>35</b>	559 [4947] <b>34</b>	648 [5735] <b>30</b>	736 [6514] <b>26</b>				38	
	23 [6]	77 [681] <b>57</b>	182 [1611] <b>56</b>	374 [3310] <b>55</b>	469 [4151] <b>53</b>	567 [5018] <b>50</b>	650 [5753] <b>46</b>	747 [6611] <b>41</b>	839 [7425] <b>37</b>	920 [8142] <b>30</b>	1002 [8868] <b>24</b>	58	
	30 [8]	76 [673] <b>75</b>	181 [1602] <b>74</b>	376 [3328] <b>71</b>	473 [4186] <b>69</b>	575 [5089] <b>65</b>	670 [5930] <b>61</b>	763 [6753] <b>56</b>	854 [7558] <b>50</b>	944 [8354] <b>43</b>	1043 [9231] <b>36</b>	76	
	38 [10]	67 [593] <b>95</b>	175 [1549] <b>94</b>	375 [3319] <b>91</b>	473 [4186] <b>89</b>	575 [5089] <b>84</b>	671 [5938] <b>79</b>	764 [6761] <b>74</b>	858 [7593] <b>68</b>	951 [8416] <b>62</b>	1048 [9275] <b>55</b>	96	
	45 [12]	57 [504] <b>113</b>	165 [1460] <b>112</b>	367 [3248] <b>109</b>	467 [4133] <b>106</b>	572 [5062] <b>102</b>	668 [5912] <b>97</b>	762 [6744] <b>90</b>	852 [7540] <b>82</b>	943 [8346] <b>77</b>	1044 [9239] <b>69</b>	114	
	53 [14]	44 [389] <b>133</b>	154 [1363] <b>132</b>	355 [3142] <b>130</b>	454 [4018] <b>127</b>	560 [4956] <b>123</b>	659 [5832] <b>118</b>	756 [6691] <b>112</b>	851 [7531] <b>104</b>	943 [8346] <b>96</b>	1032 [9133] <b>84</b>	134	
	61 [16]	32 [283] <b>153</b>	142 [1257] <b>153</b>	343 [3036] <b>149</b>	444 [3929] <b>146</b>	549 [4859] <b>141</b>	647 [5726] <b>135</b>	743 [6576] <b>129</b>	837 [7407] <b>123</b>	932 [8248] <b>114</b>		154	
	68 [18]		123 [1089] <b>170</b>	332 [2938] <b>166</b>	432 [3823] <b>162</b>	538 [4761] <b>156</b>	635 [5620] <b>150</b>	726 [6425] <b>145</b>	827 [7319] <b>137</b>			172	
	76 [20]		106 [938] <b>191</b>	316 [2797] <b>185</b>	418 [3699] <b>181</b>	523 [4629] <b>176</b>	619 [5478] <b>169</b>	717 [6345] <b>162</b>	812 [7186] <b>156</b>			192	
	83 [22]		100 [885] <b>208</b>	299 [2646] <b>205</b>	402 [3558] <b>201</b>	506 [4478] <b>195</b>	601 [5319] <b>191</b>	700 [6195] <b>183</b>	797 [7053] <b>176</b>			210	
	91 [24]		69 [611] <b>229</b>	277 [2451] <b>226</b>	378 [3345] <b>223</b>	479 [4239] <b>219</b>	579 [5124] <b>213</b>	676 [5983] <b>206</b>	773 [6841] <b>199</b>			230	
	99 [26]		46 [407] <b>249</b>	257 [2274] <b>247</b>	353 [3124] <b>245</b>	454 [4018] <b>241</b>	555 [4912] <b>236</b>	658 [5823] <b>228</b>	752 [6655] <b>222</b>			250	
114 [30]			210 [1859] <b>285</b>	307 [2717] <b>283</b>	416 [3682] <b>279</b>	517 [4575] <b>273</b>	614 [5434] <b>266</b>	710 [6284] <b>259</b>			288		
<b>Rotor Width</b>		Torque - Nm [lb-in], Speed rpm										Overall Efficiency - 70 - 100% <input type="checkbox"/> 40 - 69% <input type="checkbox"/> 0 - 39% <input type="checkbox"/>	
63.5 [2.501] mm [in]		107 [948]	221 [1952]	435 [3849]	542 [4797]	655 [5801]	763 [6749]	870 [7698]	977 [8646]	1084 [9594]	1198 [10598]		
		Theoretical Torque - Nm [lb-in]					Displacement tested at 54°C [129°F] with an oil viscosity of 46cSt [213 SUS]						

# WS (365/366 Series)

## Heavy Duty Hydraulic Motor



### DISPLACEMENT PERFORMANCE

► Performance data is typical. Performance of production units varies slightly from one motor to another. Operating at maximum continuous pressure and maximum continuous flow simultaneously is not recommended. For additional information on product testing please refer to page 6.

		Pressure - bar [psi]						Max. Cont.		Max. Inter.		
		17 [250]	35 [500]	52 [750]	69 [1000]	86 [1250]	104 [1500]	121 [1750]	138 [2000]	155 [2250]		
<b>500</b>		495 cm <sup>3</sup> [30.2 in <sup>3</sup> ] / rev										
Intermittent Ratings are below and to the right of the BOLD line. Intermittent Ratings - 10% of Operation												
Flow - lpm [gpm]	8 [2]	110 [974] <b>15</b>	236 [2089] <b>15</b>	352 [3115] <b>15</b>	467 [4133] <b>14</b>	581 [5142] <b>14</b>	699 [6186] <b>13</b>					16
	15 [4]	108 [956] <b>29</b>	241 [2133] <b>29</b>	365 [3230] <b>29</b>	488 [4319] <b>28</b>	605 [5354] <b>28</b>	739 [6540] <b>27</b>	836 [7399] <b>25</b>				30
	23 [6]	106 [938] <b>45</b>	240 [2124] <b>45</b>	366 [3239] <b>45</b>	488 [4319] <b>44</b>	610 [5399] <b>44</b>	738 [6531] <b>42</b>	851 [7531] <b>37</b>	961 [8505] <b>31</b>			46
	30 [8]	98 [867] <b>60</b>	234 [2071] <b>60</b>	359 [3177] <b>60</b>	483 [4275] <b>59</b>	604 [5345] <b>58</b>	734 [6496] <b>56</b>	849 [7514] <b>52</b>	964 [8531] <b>45</b>	1063 [9408] <b>37</b>		61
	38 [10]	87 [770] <b>76</b>	224 [1982] <b>76</b>	348 [3080] <b>76</b>	473 [4186] <b>75</b>	595 [5266] <b>74</b>	723 [6399] <b>71</b>	840 [7434] <b>67</b>	955 [8452] <b>61</b>	1063 [9408] <b>53</b>		77
	45 [12]	76 [673] <b>90</b>	210 [1859] <b>90</b>	336 [2974] <b>90</b>	463 [4098] <b>89</b>	586 [5186] <b>88</b>	714 [6319] <b>85</b>	835 [7390] <b>80</b>	952 [8425] <b>73</b>	1064 [9416] <b>65</b>		91
	53 [14]	60 [531] <b>106</b>	194 [1717] <b>106</b>	319 [2823] <b>106</b>	445 [3938] <b>105</b>	570 [5045] <b>104</b>	699 [6186] <b>101</b>	819 [7248] <b>96</b>	935 [8275] <b>88</b>	1050 [9293] <b>79</b>		107
	61 [16]	40 [354] <b>122</b>	177 [1566] <b>122</b>	303 [2682] <b>121</b>	426 [3770] <b>121</b>	550 [4868] <b>120</b>	681 [6027] <b>117</b>	805 [7124] <b>106</b>	918 [8124] <b>106</b>			123
	68 [18]		154 [1363] <b>136</b>	284 [2513] <b>136</b>	408 [3611] <b>135</b>	535 [4735] <b>134</b>	665 [5885] <b>131</b>	785 [6947] <b>126</b>				137
	76 [20]		128 [1133] <b>153</b>	261 [2310] <b>153</b>	386 [3416] <b>152</b>	510 [4514] <b>150</b>	638 [5646] <b>147</b>	761 [6735] <b>142</b>				154
	83 [22]		108 [956] <b>167</b>	237 [2097] <b>167</b>	361 [3195] <b>166</b>	487 [4310] <b>165</b>	606 [5363] <b>163</b>	738 [6531] <b>157</b>				168
	91 [24]			206 [1823] <b>183</b>	343 [3036] <b>182</b>	465 [4115] <b>180</b>	595 [5266] <b>175</b>	719 [6363] <b>170</b>				184
	99 [26]			181 [1602] <b>199</b>	317 [2805] <b>198</b>	435 [3850] <b>196</b>	574 [5080] <b>191</b>	697 [6168] <b>184</b>				200
	114 [30]			117 [1035] <b>229</b>	251 [2221] <b>229</b>	381 [3372] <b>226</b>	516 [4567] <b>221</b>	641 [5673] <b>214</b>				230
<b>Rotor Width</b>		Torque - Nm [lb-in], Speed rpm										
78.9 [3.105]		Overall Efficiency - 70 - 100% <input type="checkbox"/> 40 - 69% <input type="checkbox"/> 0 - 39% <input type="checkbox"/>										
mm [in]		134 [1185]	276 [2440]	410 [3626]	544 [4811]	678 [5996]	819 [7251]	953 [8437]	1087 [9622]	1221 [10807]		
		Theoretical Torque - Nm [lb-in] Displacement tested at 54°C [129°F] with an oil viscosity of 46cSt [213 SUS]										

**HOUSINGS**

► Dimensions shown are without paint. Paint thickness can be up to 0.13 [.005].

**2-HOLE, SAE A MOUNT**

**A0** End Ports    **A7** Side Ports

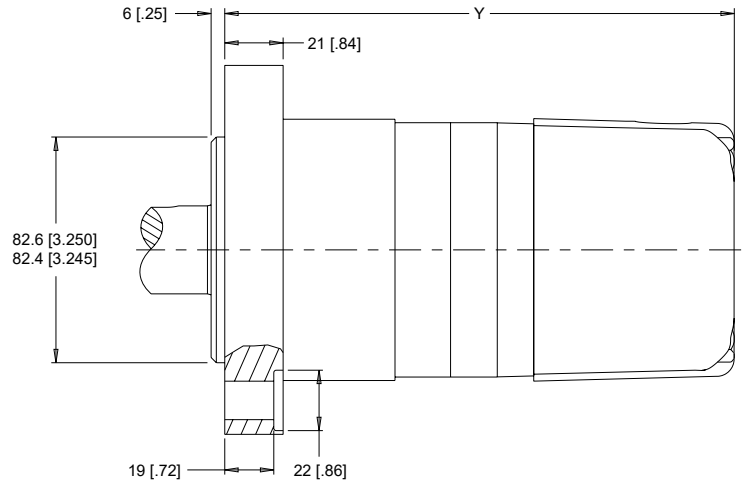
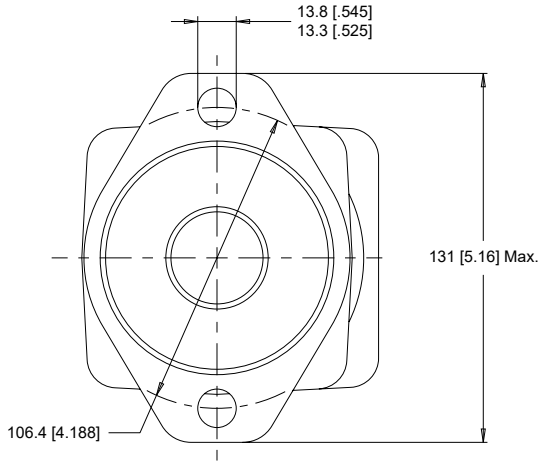

**4-HOLE, MAGNETO MOUNT**

**A2** End Ports    **A8** Side Ports

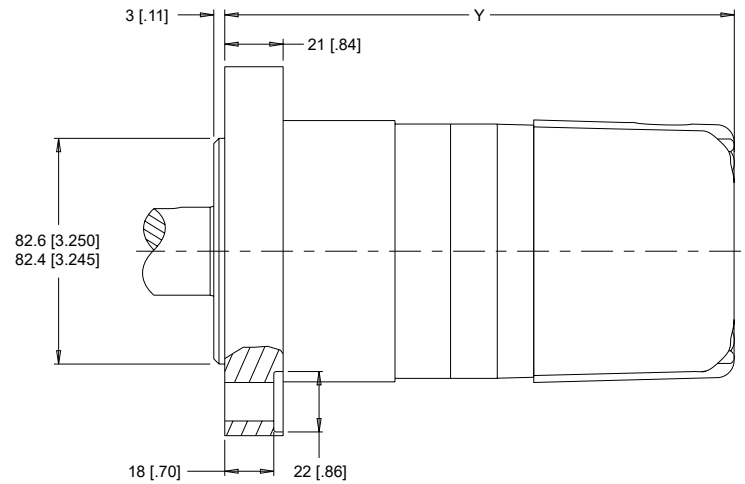
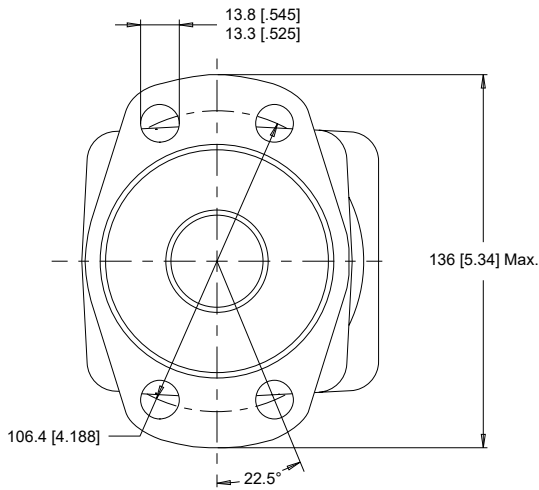

**4-HOLE, SAE A MOUNT**

**AG** End Ports    **AH** Side Ports

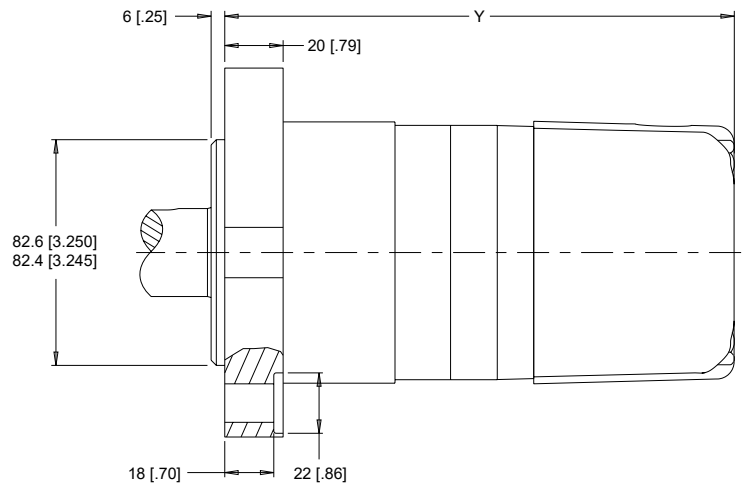
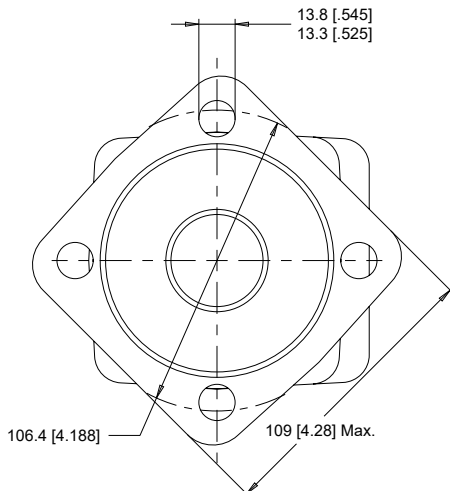

► Dimension Y is charted on page 24.

**HOUSINGS**

► Dimensions shown are without paint. Paint thickness can be up to 0.13 [.005].

**2-HOLE, SAE B MOUNT**

**B0** End Ports    **B7** Side Ports

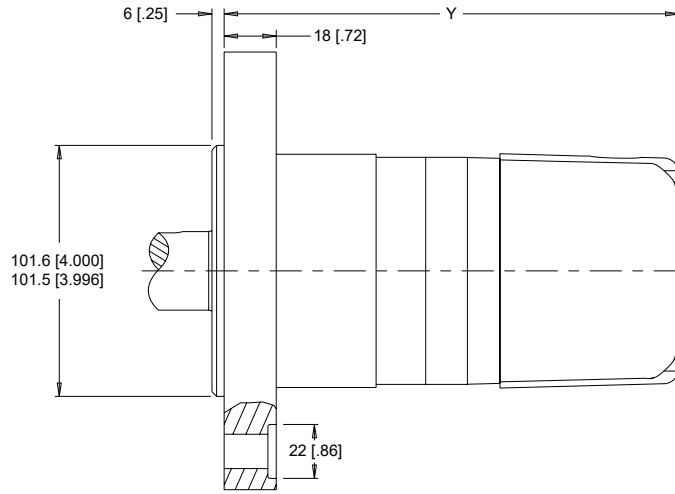
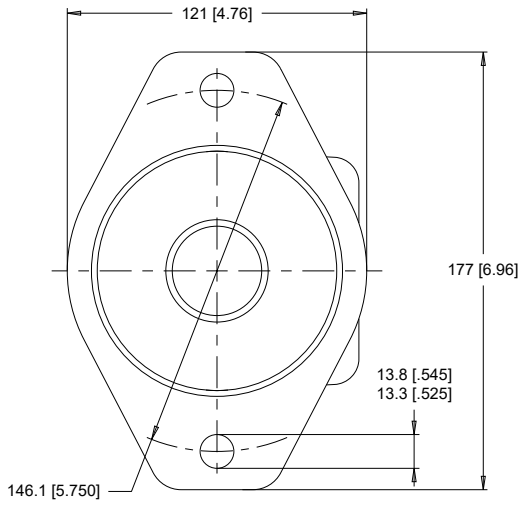

**4-HOLE, 4.25" WHEEL MOUNT**

**Y2** End Ports    **Y8** Side Ports

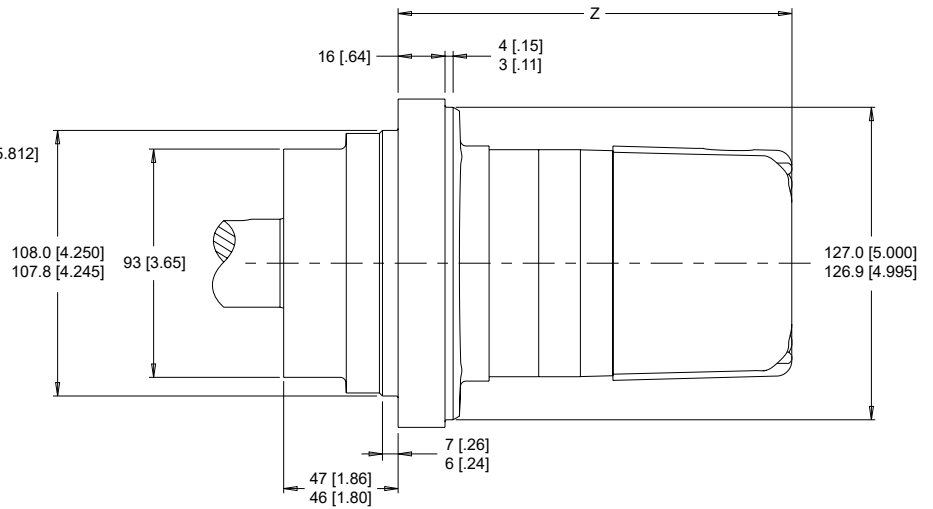
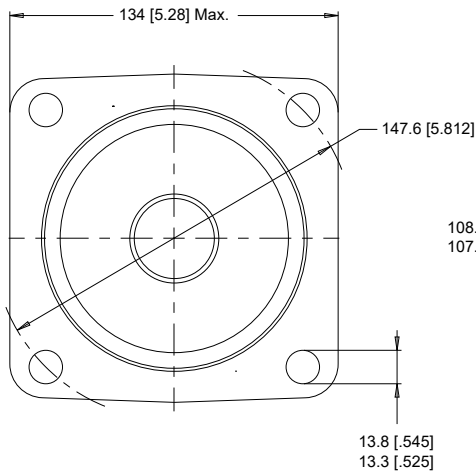

► Dimensions Y & Z are charted on page 24. Porting options listed on pages 26-27.

**LENGTH & WEIGHT CHARTS**

Dimension Y is the overall motor length from the rear of the motor to the mounting flange surface and is referenced on detailed housing drawings listed on pages 23 & 24.

Y	SAE A & B Mounts		Magneto Mounts	Weight
	#	mm [in]	mm [in]	kg [lb]
080	181 [7.12]	185 [7.27]	11.0 [24.2]	
100	185 [7.27]	189 [7.42]	11.3 [24.9]	
110	187 [7.36]	191 [7.51]	11.4 [25.1]	
130	190 [7.49]	194 [7.64]	11.5 [25.3]	
160	197 [7.74]	201 [7.89]	11.8 [26.0]	
200	204 [8.04]	208 [8.19]	12.2 [26.8]	
230	210 [8.28]	214 [8.43]	12.6 [27.7]	
250	204 [8.04]	208 [8.19]	12.2 [26.8]	
320	228 [8.99]	232 [9.14]	13.5 [29.7]	
400	228 [8.99]	232 [9.14]	13.5 [29.7]	
500	244 [9.60]	248 [9.75]	14.2 [31.2]	

► Add 1.2 kg [2.6 lb] to the weight listed to the right for SAE B mount housings.

Dimension Z is the overall motor length from the rear of the motor to the mounting flange surface and is referenced on the detailed housing drawing above.

Z	Length	Weight
	#	mm [in]
080	141 [5.55]	12.2 [26.9]
100	145 [5.69]	12.5 [27.5]
110	147 [5.78]	12.6 [27.7]
130	150 [5.91]	12.7 [27.9]
160	157 [6.16]	13.0 [28.6]
200	164 [6.46]	13.4 [29.5]
230	170 [6.70]	13.8 [30.4]
250	164 [6.46]	13.4 [29.5]
320	188 [7.41]	14.7 [32.3]
400	188 [7.41]	14.7 [32.3]
500	204 [8.02]	15.4 [33.9]

► 360 series motor weights can vary ± 1kg [2 lb] depending on model configurations such as housing, shaft, endcover, options etc.

**TECHNICAL INFORMATION**

**ALLOWABLE SHAFT LOAD / BEARING CURVE**

The bearing curve represents allowable bearing loads for a B10 life of 2,000 hours at 100 rpm. The curve includes affects of 1,000 lbs inward/outward net thrust\*. Radial loads for speeds other than 100 rpm may be calculated using the multiplication factor on page 7.

**SAE A, SAE B & MAGNETO MOUNTS**

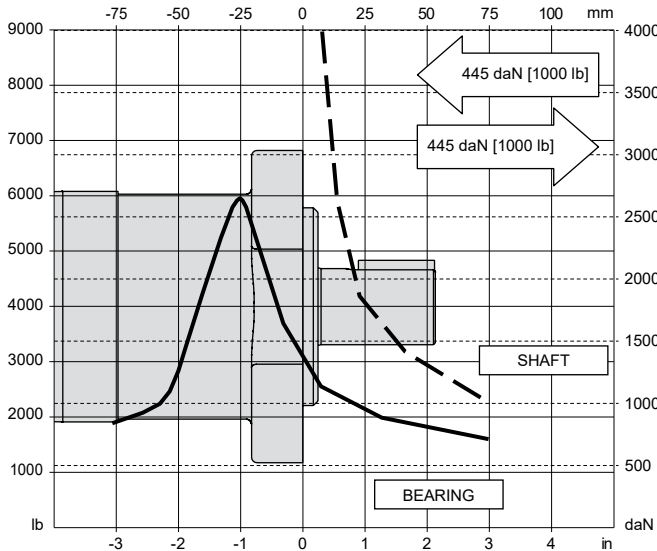

**4.25" WHEEL MOUNT**

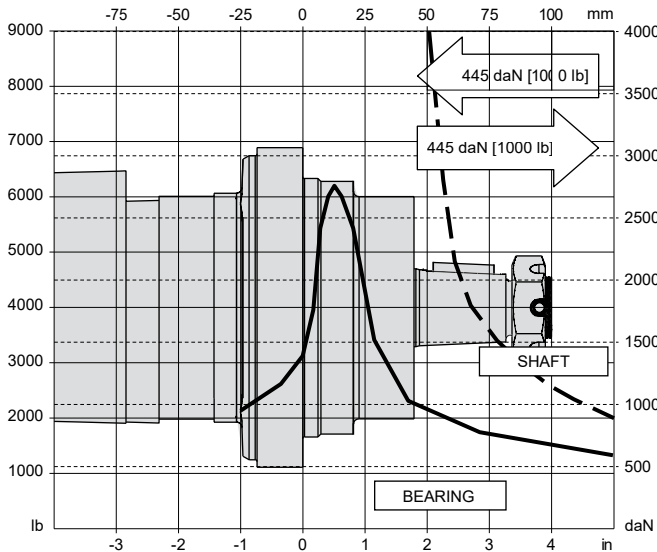

**PERMISSIBLE SHAFT SEAL PRESSURE**

**MOTORS WITH SHAFT DIAMETERS 1-1/4" OR LESS**

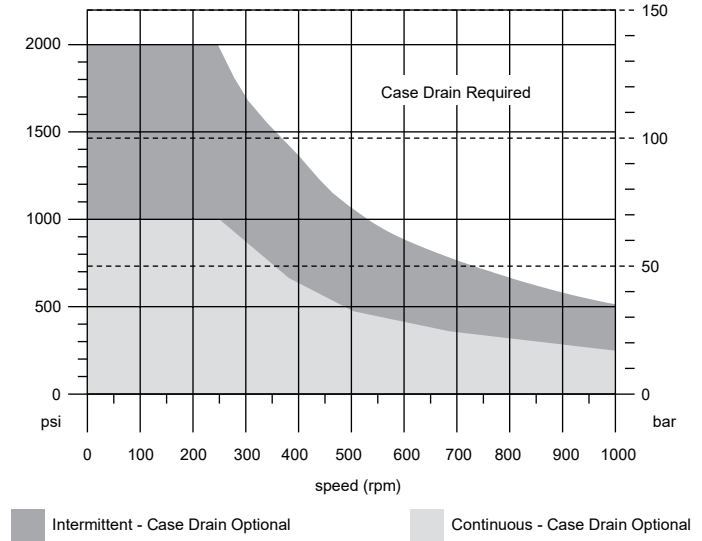

**MOTORS WITH SHAFT DIAMETERS LARGER THAN 1-1/4"**

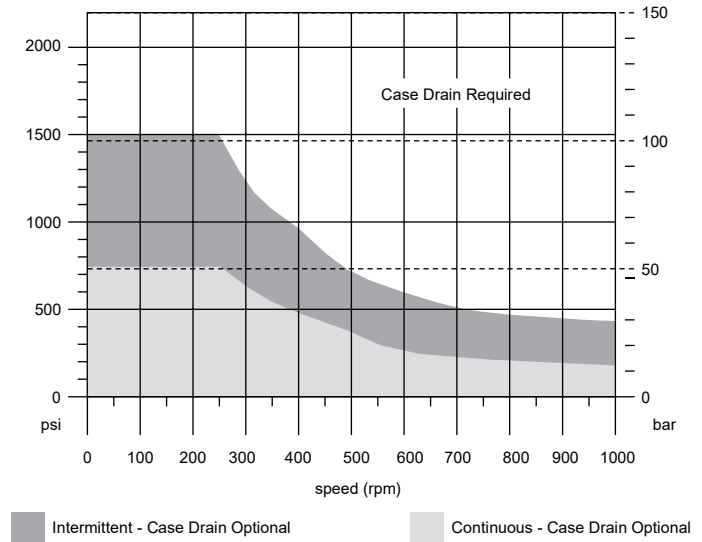

\* Case pressure will push outward on the shaft. If case drain line is attached and routed directly to tank, case pressure should be negligible. If case drain line is not attached, case pressure will be nearly the same as motor return pressure. When case pressure is acting, the allowable inward axial load can be increased and the allowable outward axial load must be decreased at a rate of 59 kg / 7 bar [130 lb / 100 psi] for shaft codes 02, 10, 12, 20, 21, 22 & 23. The rate for shaft codes 28 & 31 is 78 kg / 7 bar [175 lb / 100 psi].

**PORTING**

**SIDE PORTED - OFFSET**

**1** Main Ports **A, B:** 7/8-14 UNF  
 Drain Port **C:** 7/16-20 UNF

**2** Main Ports **A, B:** G 1/2  
 Drain Port **C:** G 1/4

STANDARD

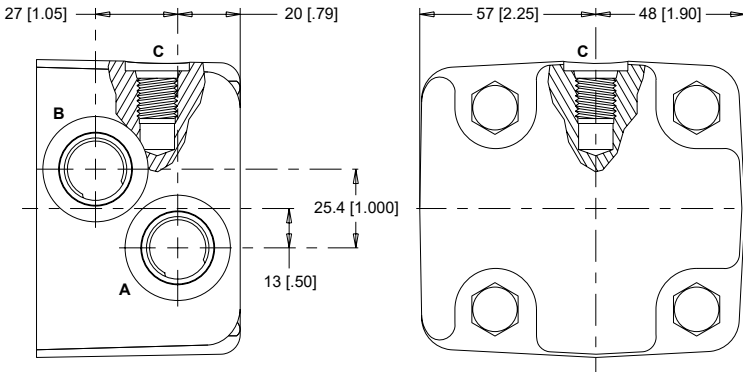

OPTIONAL

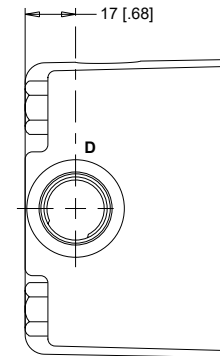

D: 10 Series/2-Way Valve Cavity 7/8-14 UNF

**SIDE PORTED - 180° OPPOSED**

**6** Main Ports **A, B:** 1 1/16-12 UN  
 Drain Port **C:** 7/16-20 UNF

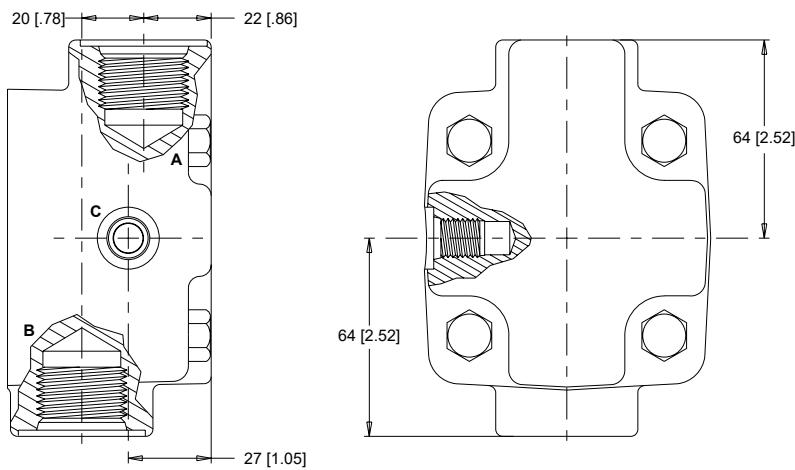

**SIDE PORTED - OFFSET MANIFOLD**

**B** Main Ports **A:** 12.7 [.500] Drilled **B:** 15.9 [.625] Drilled  
 Drain Port **C:** 7/16-20 UNF

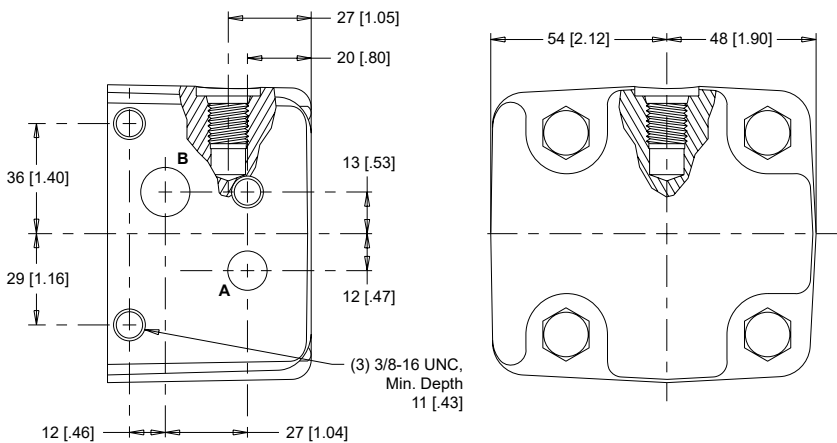

**PORTING**

**END PORTED - ALIGNED**

**1** Main Ports **A, B**: 7/8-14 UNF  
Drain Port **C**: 7/16-20 UNF

**2** Main Ports **A, B**: G 1/2  
Drain Port **C**: G 1/4

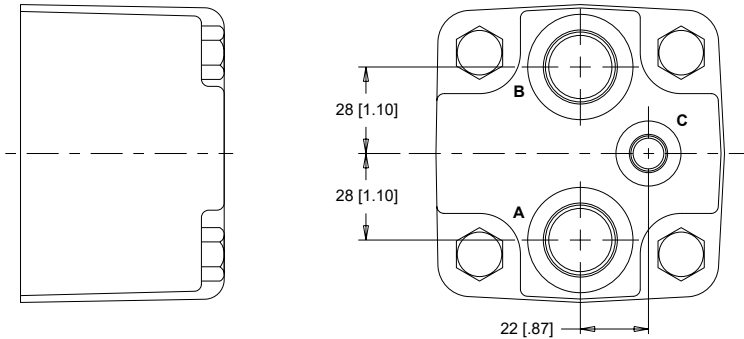

**SHAFTS**

**02** 1" 6B Spline

6B Spline  
SAE J499 Standard

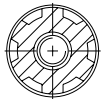

1/4-20 UNC, Min. Depth 20 [.80]

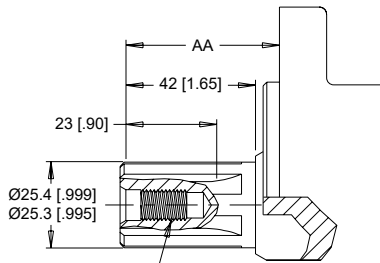

Max. Torque: 678 Nm [6000 lb-in]

**10** 1" Straight

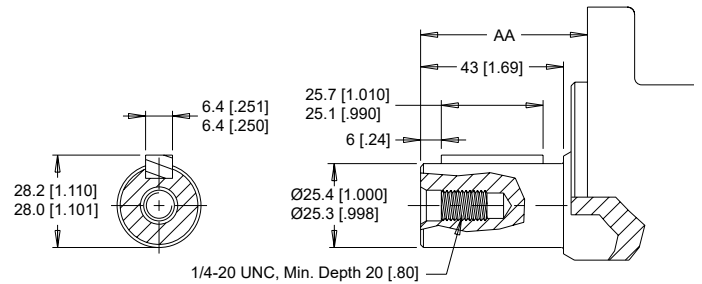

Max. Torque: 655 Nm [5800 lb-in]

**12** 25mm Straight

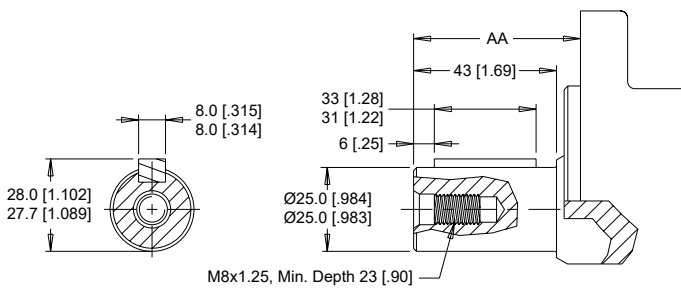

Max. Torque: 678 Nm [6000 lb-in]

**20** 1-1/4" Straight

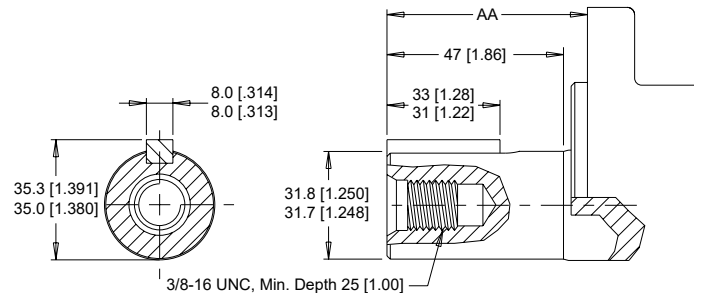

Max. Torque: 881 Nm [7800 lb-in]

► Dimension AA is charted on page 28.

**SHAFTS**

**21** 32mm Straight

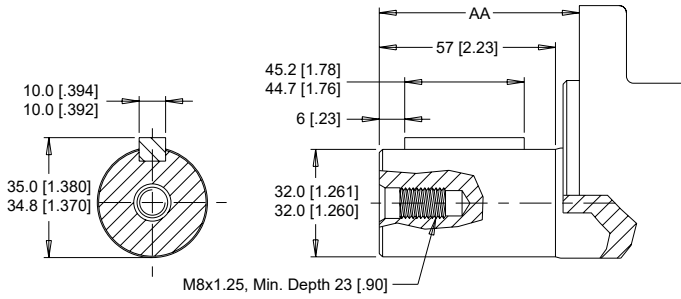

Max. Torque: 881 Nm [7800 lb-in]

**23** 14 Tooth Spline

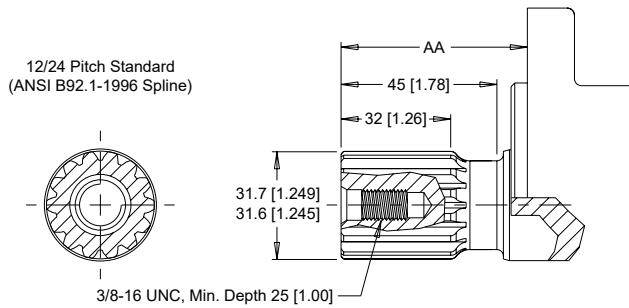

Max. Torque: 881 Nm [7800 lb-in]

**31** 1-1/2" Tapered

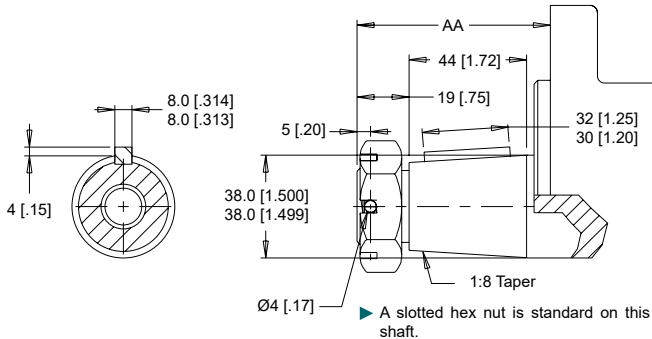

Max. Torque: 881 Nm [7800 lb-in]

**22** 1-1/4" Tapered

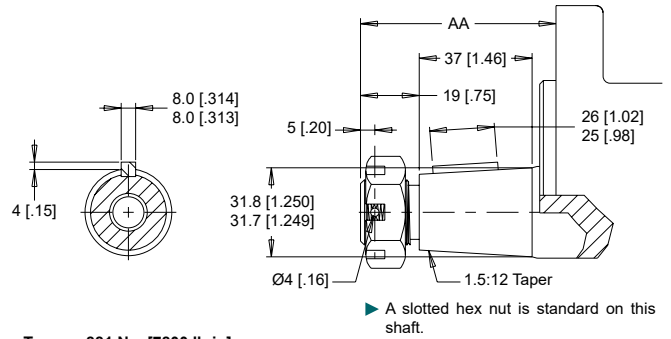

Max. Torque: 881 Nm [7800 lb-in]

► A slotted hex nut is standard on this shaft.

**28** 35mm Tapered

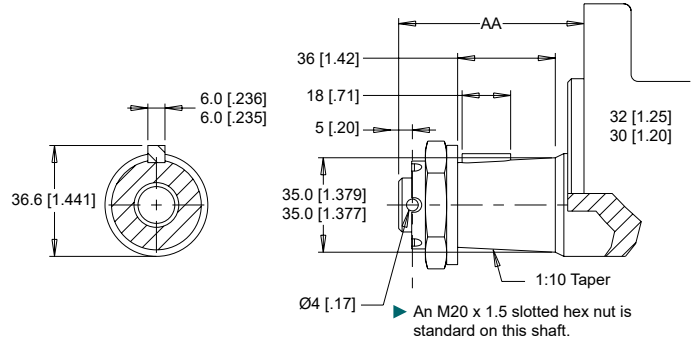

Max. Torque: 881 Nm [7800 lb-in]

► An M20 x 1.5 slotted hex nut is standard on this shaft.

**MOUNTING / SHAFT LENGTH CHART**

Dimension AA is the overall distance from the motor mounting surface to the end of the shaft and is referenced on detailed shaft drawings above as well as shafts on page 27.

AA	SAE A & B Mounts	Magneto Mounts	Wheel Mounts
#	mm [in]	mm [in]	mm [in]
02	51 [2.00]	47 [1.85]	91 [3.58]
10	51 [2.00]	47 [1.85]	91 [3.58]
12	51 [2.00]	47 [1.85]	91 [3.58]
20	55 [2.17]	52 [2.03]	96 [3.76]
21	65 [2.54]	61 [2.39]	105 [4.12]
22	64 [2.51]	60 [2.36]	104 [4.09]
23	55 [2.17]	52 [2.03]	96 [3.76]
28	N/A	N/A	107 [4.20]
31	N/A	N/A	123 [4.86]

► Shaft lengths vary ± 0.8 mm [.030 in.]

**HOUSINGS**

**4-HOLE, 4.00" PILOT MOUNT**

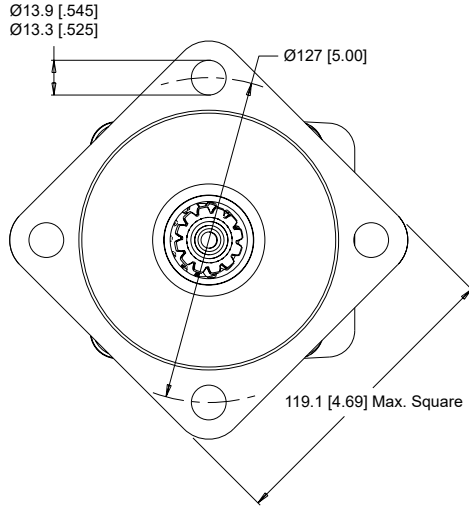

**S2** End Ports    **S8** Side Ports

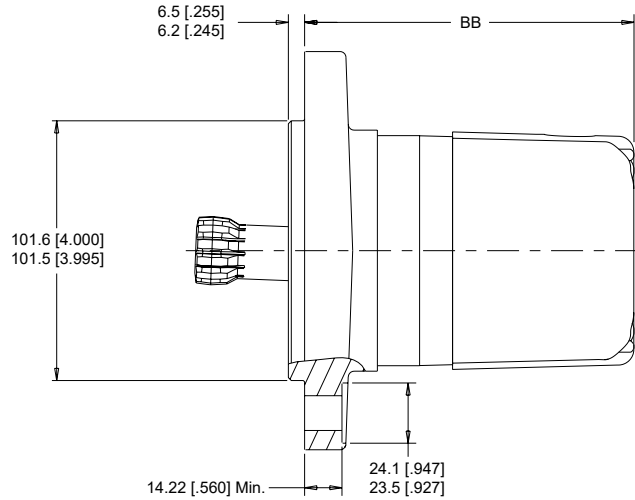

**SHAFTS**

**0B** Cardan (For Use With S2 & S8 Mounts)

Fillet Root Side Fit	
Number of Teeth	12
Pitch	12/24
Pressure Angle	30°
Pitch Diameter <i>D</i>	25.4 [1.000]
Base Diameter	21.997 [8660]
Major Diameter <i>D<sub>fl</sub></i>	27.74 [1.092] - 27.59 [1.086]
Form Diameter (Min.) <i>D<sub>fl</sub></i>	26.93 [1.060]
Minor Diameter <i>D<sub>j</sub></i>	23.224 [9143] - 23.097 [9093]
Space Width (Circular) <i>L<sub>0</sub></i> *	
Max. Actual	4.318 [1700]
Min. Effective	4.216 [1660]
Fillet Radius <i>R</i>	0.76 [030] - 0.64 [025]
Max. Distance Between Pins <i>l</i> ...	19.190 [7555] - 19.020 [7488]
Pin Diameter <i>d</i>	4.496 [1770]

with 3.38 [133] Flat for Root Clearance.

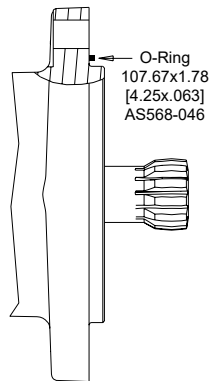

**INPUT DIMENSIONS**

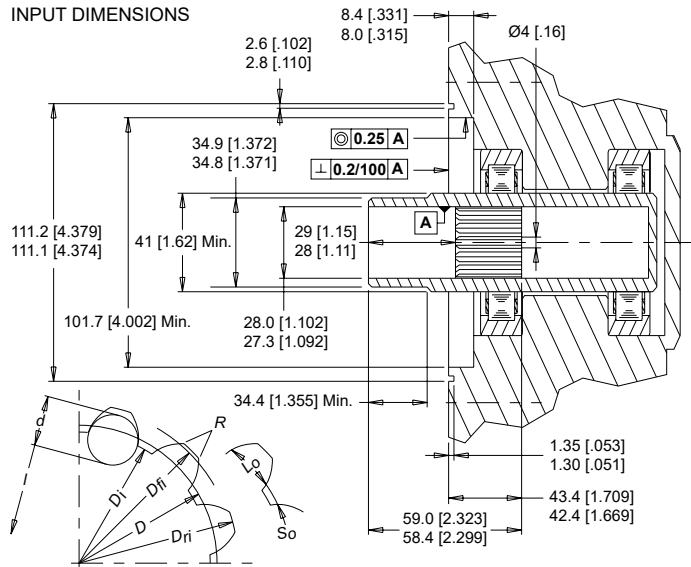

▶ The recommended shaft material is SAE 8620 or similar case hardening steel such as 20 MoCr4 (900 N/mm<sup>2</sup>) hardened to 59 - 62 HRC to a depth of 0.762 - 1.016 [030 - .040].  
\*Dimensions apply after heat treatment.

**LENGTH & WEIGHT CHART**

Dimension BB is the overall motor length from the rear of the motor to the mounting flange surface and is referenced on the detailed housing drawing above.

BB #	Length mm [in]	Weight kg [lb]
080	124 [4.88]	12.2 [26.8]
100	128 [5.04]	12.5 [27.5]
110	130 [5.14]	12.6 [27.8]
130	134 [5.27]	12.8 [28.2]
160	140 [5.52]	13.3 [29.2]
200	148 [5.82]	13.6 [29.9]
230	154 [6.06]	14.0 [30.8]
250	148 [5.82]	13.6 [29.9]
320	172 [6.77]	15.0 [32.9]
400	172 [6.77]	15.0 [32.9]
500	187 [7.37]	15.8 [34.7]

▶ 360 series short motor weights can vary ± 1kg [2lb] depending on model configurations such as housing, shaft, endcover, options etc.

**ORDERING INFORMATION**

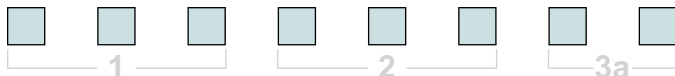

**1. CHOOSE SERIES DESIGNATION**

**365** Clockwise Rotation      **366** Counterclockwise Rotation

► The 365 & 366 series are bi-directional. Reversing the inlet hose will reverse shaft rotation.

**2. SELECT A DISPLACEMENT OPTION**

<b>080</b>	80 cm <sup>3</sup> /rev [4.9 in <sup>3</sup> /rev]	<b>230</b>	229 cm <sup>3</sup> /rev [14.0 in <sup>3</sup> /rev]
<b>100</b>	100 cm <sup>3</sup> /rev [6.1 in <sup>3</sup> /rev]	<b>250</b>	248 cm <sup>3</sup> /rev [15.1 in <sup>3</sup> /rev]
<b>110</b>	112 cm <sup>3</sup> /rev [6.8 in <sup>3</sup> /rev]	<b>320</b>	322 cm <sup>3</sup> /rev [19.6 in <sup>3</sup> /rev]
<b>130</b>	129 cm <sup>3</sup> /rev [7.9 in <sup>3</sup> /rev]	<b>400</b>	396 cm <sup>3</sup> /rev [24.2 in <sup>3</sup> /rev]
<b>160</b>	161 cm <sup>3</sup> /rev [9.8 in <sup>3</sup> /rev]	<b>500</b>	495 cm <sup>3</sup> /rev [30.2 in <sup>3</sup> /rev]
<b>200</b>	201 cm <sup>3</sup> /rev [12.3 in <sup>3</sup> /rev]		

**3a. SELECT MOUNT TYPE**

▼ **END MOUNT**

<b>A0</b>	2-Hole, SAE A Mount
<b>A2</b>	4-Hole, Magneto Mount
<b>AG</b>	4-Hole SAE A Mount
<b>B0</b>	2-Hole SAE B Mount
<b>S2</b>	4-Hole Short Motor Mount
<b>Y2</b>	4-Hole Wheel Mount

**3b. SELECT PORT SIZE**

▼ **END PORT OPTIONS**

<b>1</b>	7/8-14 UNF Aligned
<b>2</b>	G 1/2 Aligned

▼ **SIDE MOUNT**

<b>A7</b>	2-Hole, SAE A Mount
<b>A8</b>	4-Hole, Magneto Mount
<b>AH</b>	4-Hole SAE A Mount
<b>B7</b>	2-Hole SAE B Mount
<b>S8</b>	4-Hole Short Motor Mount
<b>Y8</b>	4-Hole Wheel Mount

▼ **SIDE PORT OPTIONS**

<b>1</b>	7/8-14 UNF, Offset
<b>2</b>	G 1/2, Offset
<b>6</b>	1 1/16-12 UN, 180° Opposed
<b>B</b>	Drilled Offset Manifold

► The S2 and S8 Mounts are only available with the 0B cardan shaft.



**4. SELECT A SHAFT OPTION**

<b>0B</b>	Cardan	<b>21</b>	32mm Straight
<b>02</b>	1"6B Spline	<b>22</b>	1-1/4" Tapered
<b>10</b>	1" Straight	<b>23</b>	14 Tooth Spline
<b>12</b>	25mm Straight	<b>28</b>	35mm Tapered
<b>20</b>	1-1/4" Straight	<b>31</b>	1-1/2" Tapered

► The 28 and 31 shafts are only available on the AG, AH, Y2 and Y8 mounts.

**5. SELECT A PAINT OPTION**

<b>A</b>	Black
<b>B</b>	Black, Unpainted Mounting Surface
<b>Z</b>	No Paint

► The S2 and S8 mounts are only available with no paint.

**6. SELECT A VALVE CAVITY / CARTRIDGE OPTION**

<b>A</b>	None	<b>F</b>	121 bar [1750 psi] Relief
<b>B</b>	Valve Cavity Only	<b>G</b>	138 bar [2000 psi] Relief
<b>C</b>	69 bar [1000 psi] Relief	<b>J</b>	173 bar [2500 psi] Relief
<b>D</b>	86 bar [1250 psi] Relief	<b>L</b>	207 bar [3000 psi] Relief
<b>E</b>	104 bar [1500 psi] Relief		

► Valve cavity is only available on side ports 1 & 2.

**7. SELECT AN ADD-ON OPTION**

<b>A</b>	Standard
<b>B</b>	Lock Nut
<b>C</b>	Solid Hex Nut

**8. SELECT A MISCELLANEOUS OPTION**

<b>AA</b>	None
<b>AB</b>	Internal Drain
<b>AC</b>	Freeturning Rotor
<b>MA</b>	Mounting Rotated 90°
<b>MB</b>	Freeturning Rotor With Mounting Rotated 90°

► Rotated mounting not available on the 4-Hole SAE A & wheel mounts

**OVERVIEW**

The WS targets agricultural equipment, skid steer attachments, and other applications that require greater torque under demanding conditions. Additional product features include a three zone commutator valve, heavy-duty tapered roller bearings, integral check valves, and a provision for a case drain. The WS offers numerous housing, displacement and shaft options to meet most common SAE and European requirements.

**FEATURES / BENEFITS**

- Built-in check valves offer versatility and increased seal life.
- Twelve shaft and ten mounting options to meet the most common SAE and European requirements.
- Heavy-duty tapered roller bearings for extra side load capacity.
- Three zone commutator valve for high flow capacity.
- Standard case drain with integral internal drain for extended shaft seal life.

**TYPICAL APPLICATIONS**

Heavy-duty wheel drives, sweepers, grain augers, spread-ers, feed rollers, brush drives, mowers, harvesting equipment gear box mounts and more

**SERIES DESCRIPTIONS**

**360 - Hydraulic Motor**  
*Standard*

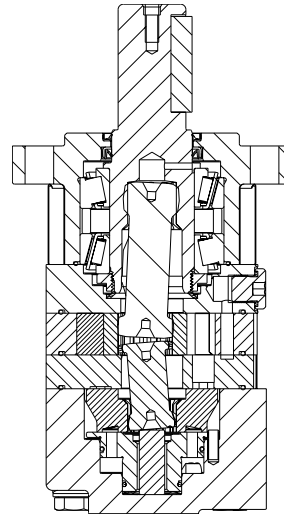

**360 - Hydraulic Motor**  
*Short*

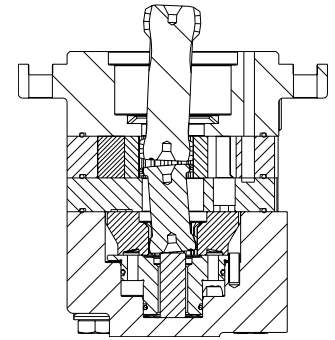

**360 - Hydraulic Motor**  
*Ultra Short*

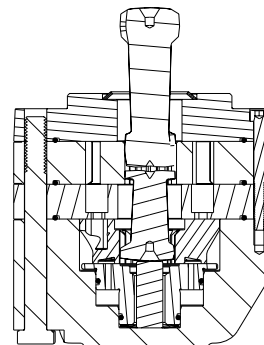

**SPECIFICATIONS**

CODE	Displacement cm <sup>3</sup> [in <sup>3</sup> /rev]	Max. Speed rpm		Max. Flow lpm [gpm]		Max. Torque Nm [lb-in]		Max. Pressure bar [psi]		
		cont.	inter.	cont.	inter.	cont.	inter.	cont.	inter.	peak
080	80 [4.9]	793	979	65 [17]	80 [21]	234 [2071]	306 [2708]	210 [3050]	275 [3990]	295 [4280]
100	100 [6.1]	744	887	75 [20]	90 [24]	301 [2664]	392 [3470]	210 [3050]	275 [3990]	295 [4280]
125	125 [7.6]	596	711	75 [20]	90 [24]	364 [3222]	478 [4231]	210 [3050]	275 [3990]	295 [4280]
160	160 [9.7]	471	561	75 [20]	90 [24]	466 [4125]	577 [5107]	210 [3050]	260 [3770]	280 [4060]
200	200 [12.2]	377	448	75 [20]	90 [24]	599 [5302]	705 [6240]	210 [3050]	250 [3630]	270 [3920]
230	226 [13.8]	324	389	75 [20]	90 [24]	652 [5771]	812 [7187]	200 [2900]	250 [3630]	270 [3920]
250	250 [15.2]	298	363	75 [20]	90 [24]	703 [6222]	851 [7532]	200 [2900]	250 [3630]	270 [3920]
315	305 [18.6]	240	293	75 [20]	90 [24]	872 [7718]	1024 [9063]	200 [2900]	240 [3480]	260 [3770]
400	393 [24.0]	185	225	75 [20]	90 [24]	910 [8054]	1069 [9462]	160 [2320]	190 [2760]	210 [3050]
500	493 [30.1]	149	180	75 [20]	90 [24]	848 [7506]	1001 [8860]	120 [1740]	140 [2030]	160 [2320]

► Performance data is typical. Performance of production units varies slightly from one motor to another. Running at intermittent ratings should not exceed 10% of every minute of operation.

**DISPLACEMENT PERFORMANCE**

		Pressure - bar [psi]								Max. Cont.		Max. Inter.	
<b>080</b>		30 [440]	70 [1020]	105 [1520]	140 [2030]	175 [2540]	210 [3050]	225 [3260]	250 [3630]	275 [3990]			
80 cm <sup>3</sup> [4.9 in <sup>3</sup> ] / rev		Intermittent Ratings are below and to the right of the BOLD line.								Intermittent Ratings - 10% of Operation			
Flow - lpm [gpm]	5 [1.3]	29 [257] <b>61</b>	76 [673] <b>58</b>	116 [1027] <b>55</b>	156 [1381] <b>45</b>	194 [1717] <b>36</b>	222 [1965] <b>31</b>					62	
	10 [2.6]	28 [248] <b>124</b>	73 [646] <b>118</b>	114 [1009] <b>110</b>	155 [1372] <b>99</b>	194 [1717] <b>87</b>	234 [2071] <b>73</b>	246 [2177] <b>67</b>	269 [2381] <b>60</b>			125	
	20 [5.3]	27 [239] <b>246</b>	72 [637] <b>241</b>	112 [991] <b>232</b>	152 [1345] <b>220</b>	191 [1690] <b>204</b>	232 [2053] <b>184</b>	248 [2195] <b>176</b>	278 [2460] <b>159</b>	303 [2682] <b>143</b>		250	
	30 [7.9]	24 [212] <b>368</b>	70 [620] <b>361</b>	110 [974] <b>354</b>	150 [1328] <b>342</b>	190 [1682] <b>322</b>	231 [2044] <b>302</b>	248 [2195] <b>293</b>	276 [2443] <b>277</b>	306 [2708] <b>254</b>		375	
	40 [10.6]	23 [204] <b>493</b>	68 [602] <b>483</b>	107 [947] <b>479</b>	146 [1292] <b>469</b>	189 [1673] <b>448</b>	229 [2027] <b>426</b>	247 [2186] <b>418</b>	277 [2451] <b>399</b>	303 [2682] <b>381</b>		499	
	50 [13.2]		66 [584] <b>607</b>	106 [938] <b>598</b>	146 [1292] <b>585</b>	186 [1646] <b>564</b>	227 [2009] <b>545</b>	245 [2168] <b>532</b>				624	
	65 [17.2]		62 [549] <b>793</b>	101 [894] <b>787</b>	141 [1248] <b>762</b>	182 [1611] <b>742</b>	225 [1991] <b>714</b>	238 [2106] <b>709</b>				811	
	80 [21.1]		56 [496] <b>979</b>	97 [858] <b>966</b>	140 [1239] <b>941</b>	178 [1575] <b>920</b>						999	
	Max. Max. Inter. Cont.		Torque - Nm [lb-in], Speed rpm										
		Overall Efficiency - 70 - 100% <input type="checkbox"/> 40 - 69% <input type="checkbox"/> 0 - 39% <input type="checkbox"/>											
Rotor Width													
	15.6 [614] mm [in]	38 [336]	89 [788]	134 [1186]	178 [1575]	223 [1974]	268 [2372]	287 [2540]	319 [2823]	351 [3107]			
		Theoretical Torque - Nm [lb-in]											
		Displacement tested at 54°C [129°F] with an oil viscosity of 46cSt [213 SUS]											

		Pressure - bar [psi]								Max. Cont.		Max. Inter.	
<b>100</b>		35 [510]	70 [1020]	105 [1520]	140 [2030]	175 [2540]	210 [3050]	225 [3260]	250 [3630]	275 [3990]			
100 cm <sup>3</sup> [6.1 in <sup>3</sup> ] / rev		Intermittent Ratings are below and to the right of the BOLD line.								Intermittent Ratings - 10% of Operation			
Flow - lpm [gpm]	5 [1.3]	47 [416] <b>49</b>	98 [867] <b>48</b>	149 [1319] <b>46</b>	198 [1752] <b>43</b>	245 [2168] <b>37</b>	284 [2513] <b>31</b>	299 [2646] <b>23</b>				50	
	10 [2.6]	46 [407] <b>99</b>	96 [850] <b>97</b>	148 [1310] <b>94</b>	199 [1761] <b>90</b>	249 [2204] <b>83</b>	297 [2628] <b>75</b>	316 [2797] <b>70</b>	349 [3089] <b>59</b>	372 [3292] <b>48</b>		100	
	20 [5.3]	45 [398] <b>197</b>	95 [841] <b>195</b>	146 [1292] <b>192</b>	198 [1752] <b>187</b>	249 [2204] <b>180</b>	301 [2664] <b>167</b>	322 [2850] <b>161</b>	357 [3159] <b>149</b>	390 [3452] <b>143</b>		200	
	30 [7.9]	43 [381] <b>297</b>	93 [823] <b>285</b>	144 [1274] <b>292</b>	195 [1726] <b>288</b>	247 [2186] <b>280</b>	297 [2628] <b>263</b>	320 [2832] <b>259</b>	356 [3151] <b>246</b>	392 [3469] <b>227</b>		300	
	40 [10.6]	40 [354] <b>395</b>	91 [805] <b>393</b>	142 [1257] <b>392</b>	193 [1708] <b>389</b>	244 [2159] <b>383</b>	295 [2611] <b>367</b>	317 [2805] <b>362</b>	354 [3133] <b>347</b>	389 [3443] <b>331</b>		400	
	50 [13.2]	37 [327] <b>495</b>	88 [779] <b>490</b>	138 [1221] <b>491</b>	191 [1690] <b>486</b>	240 [2124] <b>481</b>	295 [2611] <b>465</b>	315 [2788] <b>459</b>				500	
	60 [15.9]	35 [310] <b>594</b>	84 [743] <b>592</b>	136 [1204] <b>585</b>	187 [1655] <b>579</b>	238 [2106] <b>565</b>	289 [2558] <b>564</b>	311 [2752] <b>553</b>				600	
	75 [19.8]	28 [248] <b>744</b>	78 [690] <b>739</b>	126 [1115] <b>743</b>	183 [1620] <b>726</b>	230 [2036] <b>712</b>	286 [2531] <b>698</b>	304 [2690] <b>691</b>				750	
	90 [23.8]		70 [620] <b>887</b>	123 [1089] <b>881</b>	174 [1540] <b>874</b>	223 [1974] <b>859</b>						900	
Max. Max. Inter. Cont.		Torque - Nm [lb-in], Speed rpm											
		Overall Efficiency - 70 - 100% <input type="checkbox"/> 40 - 69% <input type="checkbox"/> 0 - 39% <input type="checkbox"/>											
Rotor Width													
	19.7 [776] mm [in]	55 [493]	111 [986]	167 [1479]	223 [1972]	278 [2465]	334 [2958]	358 [3170]	398 [3521]	438 [3874]			
		Theoretical Torque - Nm [lb-in]											
		Displacement tested at 54°C [129°F] with an oil viscosity of 46cSt [213 SUS]											

► Performance data is typical. Performance of production units varies slightly from one motor to another. Operating at maximum continuous pressure and maximum continuous flow simultaneously is not recommended. For additional information on product testing please refer to page 6.

**DISPLACEMENT PERFORMANCE**

<b>125</b>		Pressure - bar [psi]								Max. Cont.		Max. Inter.			
		35 [510]	70 [1020]	105 [1520]	140 [2030]	175 [2540]	210 [3050]	225 [3260]	250 [3630]	275 [3990]					
125 cm <sup>3</sup> [7.6 in <sup>3</sup> ] / rev		Intermittent Ratings are below and to the right of the BOLD line.										Intermittent Ratings - 10% of Operation			
Max. Max. Inter. Cont.	Flow - lpm [gpm]	5 [1.3]	51 [451] <b>39</b>	113 [1000] <b>38</b>	176 [1558] <b>35</b>	229 [2027] <b>31</b>	301 [2664] <b>26</b>	327 [2894] <b>16</b>					40	Theoretical rpm	
		10 [2.6]	50 [443] <b>79</b>	113 [1000] <b>77</b>	176 [1558] <b>74</b>	241 [2133] <b>67</b>	300 [2655] <b>60</b>	353 [3124] <b>49</b>	377 [3336] <b>46</b>	411 [3637] <b>37</b>			80		
		20 [5.3]	48 [425] <b>159</b>	109 [965] <b>157</b>	174 [1540] <b>151</b>	238 [2106] <b>146</b>	301 [2664] <b>130</b>	364 [3221] <b>115</b>	386 [3416] <b>108</b>	431 [3814] <b>95</b>	475 [4204] <b>78</b>				160
		30 [7.9]	46 [407] <b>239</b>	109 [965] <b>235</b>	172 [1522] <b>232</b>	235 [2080] <b>222</b>	298 [2637] <b>212</b>	363 [3213] <b>190</b>	391 [3460] <b>183</b>	436 [3859] <b>168</b>	478 [4230] <b>151</b>				240
		40 [10.6]	43 [381] <b>319</b>	106 [938] <b>314</b>	169 [1496] <b>311</b>	233 [2062] <b>302</b>	296 [2620] <b>291</b>	363 [3213] <b>268</b>	390 [3452] <b>260</b>	431 [3814] <b>248</b>	477 [4221] <b>229</b>				320
		50 [13.2]	40 [354] <b>399</b>	101 [894] <b>395</b>	167 [1478] <b>387</b>	233 [2062] <b>379</b>	296 [2620] <b>362</b>	363 [3213] <b>346</b>	387 [3425] <b>341</b>						400
		60 [15.9]	38 [336] <b>477</b>	100 [885] <b>472</b>	163 [1443] <b>466</b>	232 [2053] <b>457</b>	295 [2611] <b>441</b>	356 [3151] <b>433</b>	383 [3390] <b>422</b>						480
		75 [19.8]	28 [248] <b>596</b>	93 [823] <b>592</b>	155 [1372] <b>582</b>	218 [1929] <b>570</b>	283 [2505] <b>556</b>	352 [3115] <b>533</b>	376 [3328] <b>527</b>						600
		90 [23.8]		81 [717] <b>711</b>	148 [1310] <b>702</b>	214 [1894] <b>685</b>	274 [2425] <b>672</b>								720
Rotor Width		Torque - Nm [lb-in], Speed rpm										Overall Efficiency - 70 - 100% <input type="checkbox"/> 40 - 69% <input type="checkbox"/> 0 - 39% <input type="checkbox"/>			
19.7 [7.76] mm [in]		69 [616]	139 [1232]	208 [1849]	278 [2465]	348 [3081]	417 [3698]	447 [3962]	493 [4402]	547 [4842]					
		Theoretical Torque - Nm [lb-in]										Displacement tested at 54°C [129°F] with an oil viscosity of 46cSt [213 SUS]			

<b>160</b>		Pressure - bar [psi]								Max. Cont.		Max. Inter.			
		35 [510]	70 [1020]	105 [1520]	140 [2030]	160 [2320]	175 [2540]	210 [3050]	225 [3260]	260 [3770]					
160 cm <sup>3</sup> [9.7 in <sup>3</sup> ] / rev		Intermittent Ratings are below and to the right of the BOLD line.										Intermittent Ratings - 10% of Operation			
Max. Max. Inter. Cont.	Flow - lpm [gpm]	5 [1.3]	71 [628] <b>30</b>	150 [1328] <b>29</b>	232 [2053] <b>28</b>	307 [2717] <b>24</b>	356 [3151] <b>20</b>	385 [3407] <b>18</b>					31	Theoretical rpm	
		10 [2.6]	71 [628] <b>62</b>	149 [1319] <b>61</b>	230 [2036] <b>58</b>	310 [2744] <b>53</b>	355 [3142] <b>47</b>	386 [3416] <b>42</b>	459 [4062] <b>33</b>	488 [4319] <b>31</b>			62		
		20 [5.3]	69 [611] <b>123</b>	147 [1301] <b>122</b>	230 [2036] <b>119</b>	309 [2735] <b>113</b>	355 [3142] <b>107</b>	388 [3434] <b>101</b>	465 [4115] <b>84</b>	498 [4407] <b>77</b>			125		
		30 [7.9]	65 [575] <b>185</b>	143 [1266] <b>184</b>	225 [1991] <b>182</b>	307 [2717] <b>177</b>	353 [3124] <b>168</b>	387 [3425] <b>163</b>	466 [4124] <b>143</b>	500 [4425] <b>135</b>	577 [5106] <b>110</b>				187
		40 [10.6]	60 [531] <b>247</b>	138 [1221] <b>246</b>	220 [1947] <b>243</b>	303 [2682] <b>239</b>	349 [3089] <b>234</b>	383 [3390] <b>227</b>	463 [4098] <b>207</b>	497 [4398] <b>200</b>	574 [5080] <b>176</b>				250
		50 [13.2]	55 [487] <b>308</b>	133 [1177] <b>307</b>	215 [1903] <b>304</b>	296 [2620] <b>296</b>	342 [3027] <b>291</b>	376 [3328] <b>285</b>	458 [4053] <b>265</b>	490 [4337] <b>258</b>					312
		60 [15.9]	47 [416] <b>372</b>	127 [1124] <b>368</b>	207 [1832] <b>366</b>	289 [2558] <b>361</b>	336 [2974] <b>354</b>	371 [3283] <b>348</b>	452 [4000] <b>328</b>	487 [4310] <b>318</b>					375
		75 [19.8]	36 [319] <b>468</b>	114 [1009] <b>467</b>	196 [1735] <b>466</b>	279 [2469] <b>455</b>	323 [2859] <b>449</b>	361 [3195] <b>442</b>	442 [3912] <b>422</b>	472 [4177] <b>415</b>					468
		90 [23.8]	24 [212] <b>561</b>	106 [938] <b>557</b>	183 [1620] <b>549</b>	266 [2354] <b>540</b>	311 [2752] <b>533</b>								562
Rotor Width		Torque - Nm [lb-in], Speed rpm										Overall Efficiency - 70 - 100% <input type="checkbox"/> 40 - 69% <input type="checkbox"/> 0 - 39% <input type="checkbox"/>			
25.4 [1.000] mm [in]		89 [789]	178 [1578]	267 [2366]	359 [3156]	407 [3606]	445 [3944]	534 [4733]	573 [5071]	662 [5860]					
		Theoretical Torque - Nm [lb-in]										Displacement tested at 54°C [129°F] with an oil viscosity of 46cSt [213 SUS]			

► Performance data is typical. Performance of production units varies slightly from one motor to another. Operating at maximum continuous pressure and maximum continuous flow simultaneously is not recommended. For additional information on product testing please refer to page 6.

**DISPLACEMENT PERFORMANCE**

		Pressure - bar [psi]									Max. Cont.			Max. Inter.							
<b>200</b>		35 [510]	70 [1020]	105 [1520]	140 [2030]	160 [2320]	175 [2540]	210 [3050]	225 [3260]	250 [3630]											
200 cm <sup>3</sup> [12.2 in <sup>3</sup> ] / rev		<b>Intermittent Ratings are below and to the right of the BOLD line.</b>									<b>Intermittent Ratings - 10% of Operation</b>										
Max. Max. Inter. Cont.	Flow - lpm [gpm]	5 [1.3]	10 [2.6]	20 [5.3]	30 [7.9]	40 [10.6]	50 [13.2]	60 [15.9]	75 [19.8]	90 [23.8]	78 [690]	191 [1690]	289 [2558]	383 [3390]							25
											<b>24</b>	<b>21</b>	<b>23</b>	<b>20</b>							50
											77 [681]	191 [1690]	292 [2584]	382 [3381]	448 [3965]	487 [4310]	573 [5071]				100
											<b>49</b>	<b>48</b>	<b>47</b>	<b>44</b>	<b>39</b>	<b>35</b>	<b>26</b>				150
											73 [646]	189 [1673]	291 [2575]	393 [3478]	451 [3991]	494 [4372]	591 [5230]	632 [5593]	694 [6142]		200
											<b>99</b>	<b>98</b>	<b>96</b>	<b>93</b>	<b>88</b>	<b>83</b>	<b>70</b>	<b>63</b>	<b>52</b>		250
											71 [628]	186 [1646]	289 [2558]	389 [3443]	453 [4009]	491 [4345]	599 [5301]	633 [5602]	704 [6230]		300
											<b>149</b>	<b>147</b>	<b>146</b>	<b>145</b>	<b>137</b>	<b>133</b>	<b>119</b>	<b>111</b>	<b>95</b>		375
											66 [584]	181 [1602]	283 [2505]	385 [3407]	443 [3921]	486 [4301]	591 [5230]	631 [5584]	705 [6239]		450
											<b>197</b>	<b>196</b>	<b>196</b>	<b>195</b>	<b>191</b>	<b>187</b>	<b>174</b>	<b>169</b>	<b>154</b>		
										59 [522]	176 [1558]	277 [2451]	378 [3345]	438 [3877]	481 [4257]	582 [5151]	625 [5531]				
										<b>249</b>	<b>247</b>	<b>246</b>	<b>244</b>	<b>237</b>	<b>227</b>	<b>220</b>					
										51 [451]	168 [1487]	269 [2381]	371 [3283]	428 [3788]	474 [4195]	571 [5053]	611 [5407]				
										<b>297</b>	<b>295</b>	<b>294</b>	<b>292</b>	<b>287</b>	<b>278</b>	<b>264</b>	<b>256</b>				
										40 [354]	154 [1363]	256 [2266]	352 [3115]	409 [3620]	454 [4018]	556 [4921]	601 [5319]				
										<b>371</b>	<b>377</b>	<b>375</b>	<b>369</b>	<b>362</b>	<b>355</b>	<b>338</b>	<b>327</b>				
										26 [230]	139 [1230]	238 [2106]	338 [2991]	398 [3523]							
										<b>448</b>	<b>444</b>	<b>448</b>	<b>436</b>	<b>429</b>							
	<b>Rotor Width</b>	Torque - Nm [lb-in], Speed rpm																			
	31.8 [1.252]	Overall Efficiency - 70 - 100% <input type="checkbox"/> 40 - 69% <input type="checkbox"/> 0 - 39% <input type="checkbox"/>																			
	mm [in]	111 [986]	222 [1972]	334 [2958]	445 [3944]	509 [4508]	557 [4930]	668 [5917]	716 [6339]	795 [7044]											
		Theoretical Torque - Nm [lb-in] Displacement tested at 54°C [129°F] with an oil viscosity of 46cSt [213 SUS]																			

		Pressure - bar [psi]									Max. Cont.			Max. Inter.							
<b>230</b>		35 [510]	70 [1020]	95 [1380]	125 [1810]	140 [2030]	155 [2250]	175 [2540]	200 [2900]	225 [3260]	250 [3630]										
226 cm <sup>3</sup> [13.8 in <sup>3</sup> ] / rev		<b>Intermittent Ratings are below and to the right of the BOLD line.</b>									<b>Intermittent Ratings - 10% of Operation</b>										
Max. Max. Inter. Cont.	Flow - lpm [gpm]	5 [1.3]	10 [2.6]	20 [5.3]	30 [7.9]	40 [10.6]	50 [13.2]	60 [15.9]	75 [19.8]	90 [23.8]	113 [1000]	232 [2053]	320 [2832]							22	
											<b>21</b>	<b>20</b>	<b>19</b>							44	
											112 [991]	228 [2018]	321 [2841]	419 [3708]	465 [4115]	518 [4584]	569 [5036]	651 [5761]			89
											<b>42</b>	<b>41</b>	<b>40</b>	<b>37</b>	<b>36</b>	<b>34</b>	<b>33</b>	<b>30</b>			133
											111 [982]	227 [2009]	315 [2788]	415 [3673]	461 [4080]	514 [4549]	582 [5151]	652 [5770]	735 [6505]	812 [7186]	177
											<b>86</b>	<b>85</b>	<b>83</b>	<b>78</b>	<b>75</b>	<b>72</b>	<b>69</b>	<b>65</b>	<b>61</b>	<b>55</b>	222
											108 [956]	223 [1974]	311 [2752]	412 [3647]	463 [4098]	512 [4531]	576 [5098]	658 [5823]	738 [6531]		266
											<b>128</b>	<b>126</b>	<b>124</b>	<b>119</b>	<b>116</b>	<b>113</b>	<b>108</b>	<b>102</b>	<b>97</b>		332
											103 [912]	220 [1947]	306 [2708]	410 [3629]	460 [4071]	510 [4514]	572 [5062]	651 [5761]	729 [6452]		399
											<b>171</b>	<b>169</b>	<b>166</b>	<b>161</b>	<b>158</b>	<b>153</b>	<b>148</b>	<b>142</b>	<b>136</b>		
										97 [858]	214 [1894]	296 [2620]	407 [3602]	446 [3947]	503 [4452]	571 [5053]					
										<b>216</b>	<b>215</b>	<b>213</b>	<b>206</b>	<b>203</b>	<b>199</b>	<b>192</b>					
										89 [788]	212 [1876]	290 [2567]	399 [3531]	440 [3894]	496 [4390]	554 [4903]					
										<b>259</b>	<b>256</b>	<b>253</b>	<b>247</b>	<b>244</b>	<b>239</b>	<b>234</b>					
										76 [673]	190 [1682]	275 [2434]	388 [3434]	425 [3761]	481 [4257]	546 [4832]					
										<b>324</b>	<b>321</b>	<b>320</b>	<b>310</b>	<b>309</b>	<b>304</b>	<b>300</b>					
										56 [496]	174 [1540]	257 [2274]	361 [3195]	411 [3637]							
										<b>389</b>	<b>386</b>	<b>383</b>	<b>378</b>	<b>374</b>							
	<b>Rotor Width</b>	Torque - Nm [lb-in], Speed rpm																			
	45.4 [1.787]	Overall Efficiency - 70 - 100% <input type="checkbox"/> 40 - 69% <input type="checkbox"/> 0 - 39% <input type="checkbox"/>																			
	mm [in]	126 [1115]	251 [2222]	341 [3018]	449 [3974]	503 [4452]	557 [4930]	628 [5558]	718 [6355]	808 [7152]	898 [7948]										
		Theoretical Torque - Nm [lb-in] Displacement tested at 54°C [129°F] with an oil viscosity of 46cSt [213 SUS]																			

► Performance data is typical. Performance of production units varies slightly from one motor to another. Operating at maximum continuous pressure and maximum continuous flow simultaneously is not recommended. For additional information on product testing please refer to page 6.

**DISPLACEMENT PERFORMANCE**

<b>250</b>		Pressure - bar [psi]								Max. Cont.	Max. Inter.			
		35 [510]	70 [1020]	95 [1380]	125 [1810]	140 [2030]	155 [2250]	175 [2540]	200 [2900]	225 [3260]	250 [3630]			
250 cm <sup>3</sup> [15.2 in <sup>3</sup> ] / rev		<b>Intermittent Ratings are below and to the right of the BOLD line.</b>								<b>Intermittent Ratings - 10% of Operation</b>				
Max. Max. Inter. Cont.	Flow - lpm [gpm]	5 [1.3]	115 [1018] <b>19</b>									20	Theoretical rpm	
		10 [2.6]	116 [1027] <b>39</b>	239 [2115] <b>38</b>	331 [2929] <b>37</b>	439 [3885] <b>35</b>	481 [4257] <b>33</b>	532 [4708] <b>31</b>	595 [5266] <b>27</b>			40		
		20 [5.3]	114 [1009] <b>79</b>	239 [2115] <b>78</b>	330 [2921] <b>76</b>	438 [3876] <b>73</b>	491 [4345] <b>70</b>	546 [4832] <b>67</b>	619 [5478] <b>62</b>	703 [6222] <b>54</b>	778 [6885] <b>45</b>	851 [7531] <b>38</b>		80
		30 [7.9]	110 [974] <b>119</b>	236 [2089] <b>118</b>	329 [2912] <b>117</b>	437 [3868] <b>115</b>	489 [4328] <b>112</b>	543 [4806] <b>109</b>	618 [5469] <b>103</b>	704 [6230] <b>93</b>	790 [6992] <b>78</b>			120
		40 [10.6]	106 [938] <b>159</b>	232 [2053] <b>158</b>	323 [2859] <b>155</b>	430 [3806] <b>154</b>	486 [4301] <b>153</b>	539 [4770] <b>150</b>	624 [5522] <b>145</b>	702 [6213] <b>133</b>	793 [7018] <b>124</b>			160
		50 [13.2]	100 [885] <b>198</b>	225 [1991] <b>197</b>	318 [2814] <b>194</b>	429 [3797] <b>195</b>	480 [4248] <b>193</b>	530 [4691] <b>191</b>	609 [5390] <b>185</b>					200
		60 [15.9]	91 [805] <b>239</b>	215 [1903] <b>237</b>	311 [2752] <b>240</b>	414 [3664] <b>235</b>	470 [4160] <b>234</b>	524 [4637] <b>233</b>	594 [5257] <b>223</b>					240
		75 [19.8]	78 [690] <b>298</b>	206 [1823] <b>295</b>	293 [2593] <b>295</b>	405 [3584] <b>292</b>	453 [4009] <b>291</b>	507 [4487] <b>285</b>	581 [5142] <b>277</b>					300
		90 [23.8]	59 [522] <b>359</b>	184 [1628] <b>357</b>	272 [2407] <b>363</b>	384 [3398] <b>353</b>	422 [3735] <b>350</b>							360
<b>Rotor Width</b>		Torque - Nm [lb-in], <b>Speed rpm</b>								Overall Efficiency - 70 - 100% <input type="checkbox"/> 40 - 69% <input type="checkbox"/> 0 - 39% <input type="checkbox"/>				
39.4 [1.551]		139 [1232]	278 [2465]	378 [3346]	497 [4402]	557 [4930]	616 [5458]	696 [6163]	795 [7043]	895 [7924]	994 [8804]			
mm [in]		Theoretical Torque - Nm [lb-in]								Displacement tested at 54°C [129°F] with an oil viscosity of 46cSt [213 SUS]				

<b>315</b>		Pressure - bar [psi]								Max. Cont.	Max. Inter.			
		35 [510]	70 [1020]	100 [1450]	120 [1740]	140 [2030]	160 [2320]	175 [2540]	200 [2900]	225 [3260]	240 [3480]			
305 cm <sup>3</sup> [18.6 in <sup>3</sup> ] / rev		<b>Intermittent Ratings are below and to the right of the BOLD line.</b>								<b>Intermittent Ratings - 10% of Operation</b>				
Max. Max. Inter. Cont.	Flow - lpm [gpm]	5 [1.3]	147 [1301] <b>15</b>	310 [2744] <b>14</b>	426 [3770] <b>13</b>							16	Theoretical rpm	
		10 [2.6]	153 [1354] <b>32</b>	308 [2726] <b>30</b>	441 [3903] <b>29</b>	527 [4664] <b>25</b>	600 [5310] <b>23</b>	670 [5930] <b>20</b>				33		
		20 [5.3]	151 [1336] <b>64</b>	304 [2690] <b>62</b>	441 [3903] <b>60</b>	530 [4691] <b>57</b>	610 [5399] <b>52</b>	705 [6239] <b>46</b>				66		
		30 [7.9]	146 [1292] <b>94</b>	303 [2682] <b>94</b>	439 [3885] <b>92</b>	532 [4708] <b>88</b>	617 [5460] <b>83</b>	700 [6196] <b>76</b>	764 [6761] <b>73</b>	872 [7717] <b>65</b>	980 8673] <b>64</b>	1024 [9062] <b>59</b>		98
		40 [10.6]	139 [1230] <b>127</b>	295 [2611] <b>125</b>	431 [3814] <b>124</b>	520 [4602] <b>121</b>	613 [5425] <b>117</b>	701 [6205] <b>111</b>	766 [6779] <b>105</b>	883 [7815] <b>95</b>	940 [8319] <b>94</b>			131
		50 [13.2]	130 [1151] <b>160</b>	288 [2549] <b>158</b>	423 [3744] <b>156</b>	514 [4549] <b>153</b>	604 [5345] <b>149</b>	694 [6143] <b>144</b>	759 [6717] <b>139</b>					164
		60 [15.9]	126 [1115] <b>191</b>	277 [2451] <b>191</b>	417 [3690] <b>187</b>	506 [4478] <b>186</b>	594 [5257] <b>182</b>	684 [6054] <b>174</b>	749 [6629] <b>168</b>					197
		75 [19.8]	99 [876] <b>240</b>	258 [2283] <b>237</b>	394 [3487] <b>237</b>	483 [4275] <b>234</b>	573 [5071] <b>226</b>	651 [5762] <b>222</b>						246
		90 [23.8]	74 [655] <b>293</b>	231 [2044] <b>293</b>	371 [3283] <b>284</b>	460 [4071] <b>281</b>	543 [4806] <b>276</b>							295
<b>Rotor Width</b>		Torque - Nm [lb-in], <b>Speed rpm</b>								Overall Efficiency - 70 - 100% <input type="checkbox"/> 40 - 69% <input type="checkbox"/> 0 - 39% <input type="checkbox"/>				
49.2 [1.937]		170 [1505]	339 [3000]	485 [4293]	582 [5151]	679 [6010]	776 [6868]	848 [7506]	970 [8585]	1091 [9656]	1163 [10294]			
mm [in]		Theoretical Torque - Nm [lb-in]								Displacement tested at 54°C [129°F] with an oil viscosity of 46cSt [213 SUS]				

► Performance data is typical. Performance of production units varies slightly from one motor to another. Operating at maximum continuous pressure and maximum continuous flow simultaneously is not recommended. For additional information on product testing please refer to page 6.

**DISPLACEMENT PERFORMANCE**

		Pressure - bar [psi]								Max. Cont.	Max. Inter.	
<b>400</b>		30 [440]	60 [870]	80 [1160]	105 [1520]	120 [1740]	140 [2030]	160 [2320]	175 [2540]	190 [2760]		
393 cm <sup>3</sup> [24.0 in <sup>3</sup> ] / rev		<b>Intermittent Ratings are below and to the right of the BOLD line.</b>								<b>Intermittent Ratings - 10% of Operation</b>		
Max. Max. Inter. Cont.	Flow - lpm [gpm]	5 [1.3]	10 [2.6]	20 [5.3]	30 [7.9]	40 [10.6]	50 [13.2]	60 [15.9]	75 [19.8]	90 [23.8]	13	Theoretical rpm
		167 [1478] <b>12</b>	352 [3115] <b>12</b>								25	
		176 [1531] <b>24</b>	345 [3053] <b>23</b>	461 [4080] <b>22</b>	606 [5363] <b>21</b>						51	
		170 [1505] <b>49</b>	342 [3027] <b>48</b>	463 [4098] <b>47</b>	610 [5399] <b>46</b>	695 [6151] <b>43</b>	809 [7160] <b>39</b>	910 [8054] <b>33</b>	987 [8735] <b>29</b>		76	
		163 [1443] <b>74</b>	337 [2982] <b>73</b>	456 [4036] <b>73</b>	605 [5354] <b>71</b>	691 [6115] <b>69</b>	806 [7134] <b>64</b>	916 [8107] <b>58</b>	990 [8762] <b>45</b>	1069 [9461] <b>39</b>	102	
		153 [1354] <b>98</b>	327 [2894] <b>98</b>	445 [3938] <b>98</b>	593 [5248] <b>96</b>	681 [6027] <b>95</b>	799 [7072] <b>90</b>	911 [8062] <b>82</b>	982 [8691] <b>69</b>		127	
		142 [1257] <b>123</b>	317 [2805] <b>123</b>	435 [3850] <b>122</b>	575 [5089] <b>121</b>	667 [5903] <b>120</b>	787 [6966] <b>115</b>				153	
		131 [1159] <b>149</b>	301 [2664] <b>148</b>	419 [3708] <b>147</b>	566 [5009] <b>144</b>	653 [5779] <b>144</b>	774 [6851] <b>140</b>				191	
		100 [885] <b>185</b>	276 [2443] <b>185</b>	393 [3478] <b>184</b>	541 [4788] <b>183</b>	628 [5558] <b>181</b>					229	
	72 [637] <b>224</b>	247 [2186] <b>222</b>	360 [3186] <b>221</b>	511 [4522] <b>220</b>								
<b>Rotor Width</b>		Torque - Nm [lb-in], Speed rpm										
63.5 [2.500] mm [in]		Overall Efficiency - 70 - 100% <input type="checkbox"/> 40 - 69% <input type="checkbox"/> 0 - 39% <input type="checkbox"/>										
		187 [1655]	375 [3319]	500 [4426]	656 [5806]	750 [6638]	875 [7745]	1000 [8851]	1093 [9674]	1187 [10506]		
		Theoretical Torque - Nm [lb-in] Displacement tested at 54°C [129°F] with an oil viscosity of 46cSt [213 SUS]										

		Pressure - bar [psi]						Max. Cont.	Max. Inter.		
<b>500</b>		25 [360]	50 [730]	80 [1160]	90 [1300]	105 [1520]	120 [1740]	140 [2030]			
493 cm <sup>3</sup> [30.1 in <sup>3</sup> ] / rev		<b>Intermittent Ratings are below and to the right of the BOLD line.</b>						<b>Intermittent Ratings - 10% of Operation</b>			
Max. Max. Inter. Cont.	Flow - lpm [gpm]	10 [2.6]	20 [5.3]	30 [7.9]	40 [10.6]	50 [13.2]	60 [15.9]	75 [19.8]	90 [23.8]	20	Theoretical rpm
		191 [1690] <b>19</b>	355 [3142] <b>18</b>							41	
		175 [1549] <b>39</b>	354 [3133] <b>39</b>	571 [5053] <b>36</b>	646 [5717] <b>34</b>	760 [6726] <b>31</b>				61	
		164 [1451] <b>59</b>	344 [3044] <b>58</b>	565 [5000] <b>56</b>	637 [5637] <b>55</b>	743 [6576] <b>52</b>	848 [7506] <b>48</b>	1001 [8859] <b>38</b>		81	
		147 [1301] <b>79</b>	333 [2947] <b>78</b>	551 [4876] <b>77</b>	623 [5514] <b>76</b>	730 [6461] <b>74</b>	833 [7373] <b>70</b>			102	
		136 [1204] <b>99</b>	317 [2805] <b>99</b>	537 [4752] <b>96</b>	610 [5399] <b>95</b>	717 [6345] <b>93</b>	830 [7346] <b>86</b>			122	
		118 [1044] <b>119</b>	302 [2673] <b>118</b>	523 [4629] <b>116</b>	597 [5283] <b>114</b>	704 [6230] <b>110</b>				152	
		94 [832] <b>148</b>	270 [2390] <b>149</b>	490 [4337] <b>145</b>	566 [5009] <b>143</b>	674 [5965] <b>141</b>				183	
		55 [487] <b>179</b>	237 [2097] <b>180</b>	457 [4044] <b>175</b>	530 [4691] <b>174</b>						
<b>Rotor Width</b>		Torque - Nm [lb-in], Speed rpm									
78.8 [3.102] mm [in]		Overall Efficiency - 70 - 100% <input type="checkbox"/> 40 - 69% <input type="checkbox"/> 0 - 39% <input type="checkbox"/>									
		196 [1735]	392 [3470]	627 [5550]	706 [6249]	823 [7284]	941 [8329]	1098 [9718]			
		Theoretical Torque - Nm [lb-in] Displacement tested at 54°C [129°F] with an oil viscosity of 46cSt [213 SUS]									

► Performance data is typical. Performance of production units varies slightly from one motor to another. Operating at maximum continuous pressure and maximum continuous flow simultaneously is not recommended. For additional information on product testing please refer to page 6.

**HOUSINGS**

► Dimensions shown are without paint. Paint thickness can be up to 0.13 [0.005].

**2-HOLE, SAE A MOUNT**

**A7** Side Ports

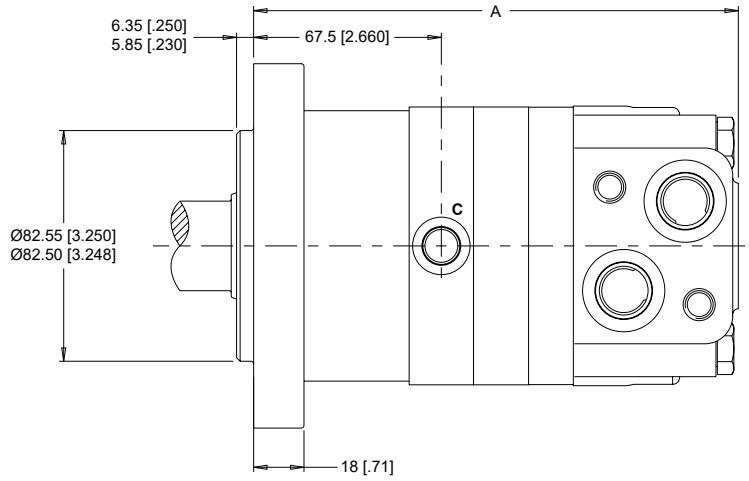
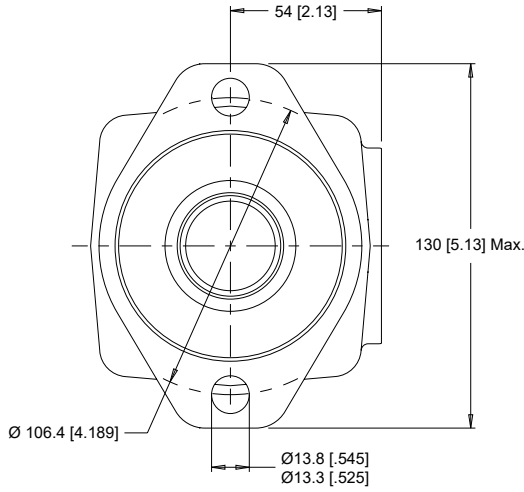

**4-HOLE, SAE A MOUNT**

**AH** Side Ports

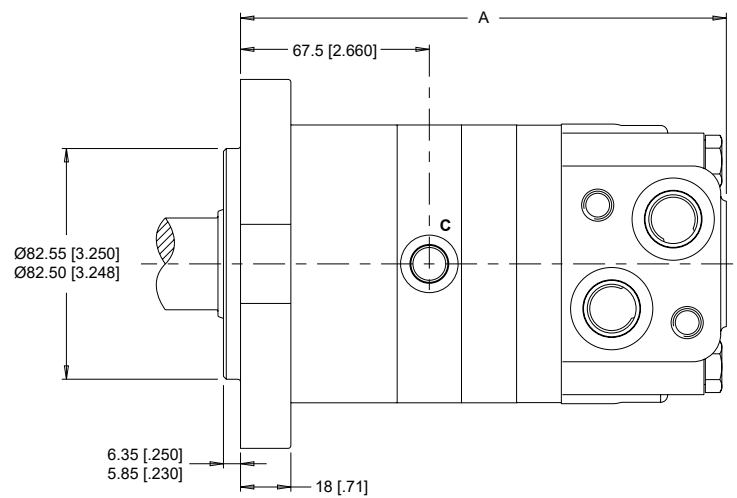
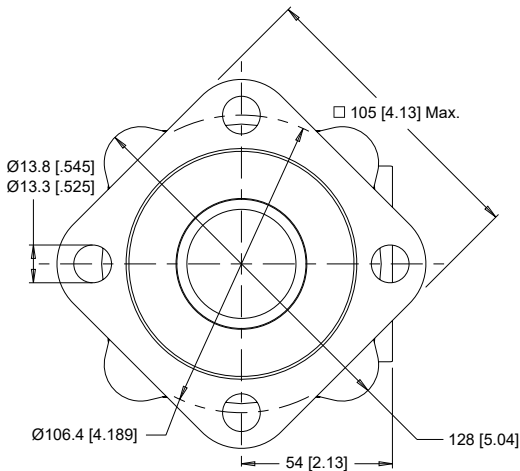

**6-HOLE, MAGNETO MOUNT**

**AT** Side Ports

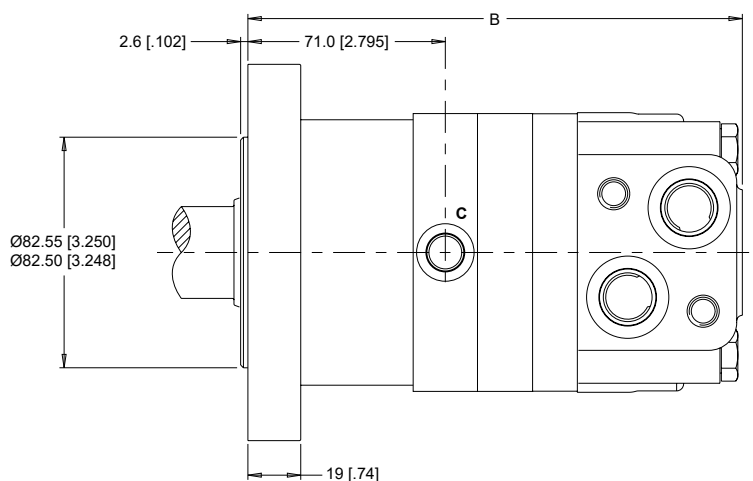
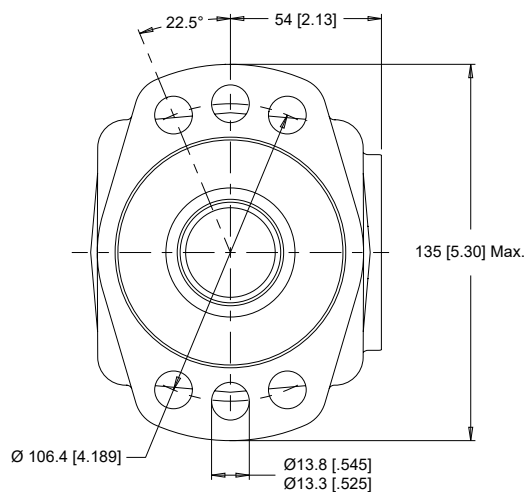

► Dimension A & B are charted on page 40.

**HOUSINGS**

► Dimensions shown are without paint. Paint thickness can be up to 0.13 [.005].

**4-HOLE, SQUARE EURO MOUNT**

**AU** Side Ports

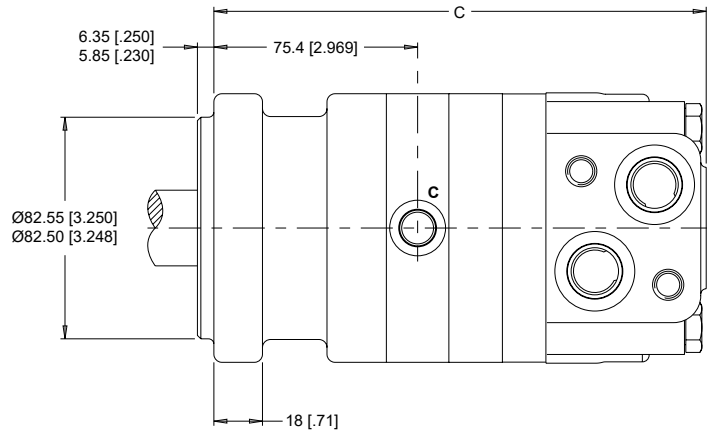
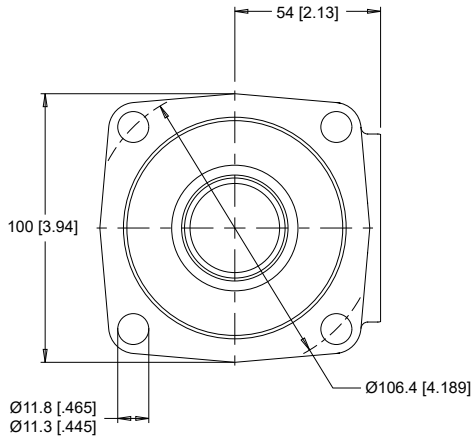

**2-HOLE, SAE B MOUNT**

**B7** Side Ports

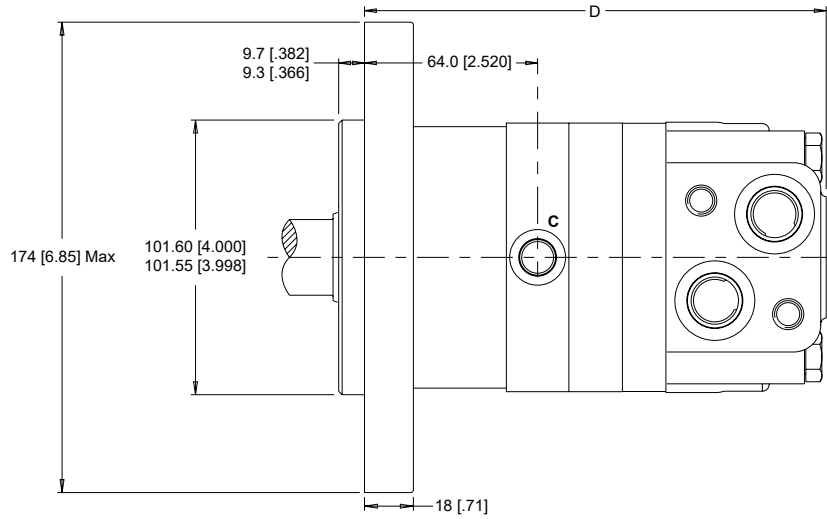
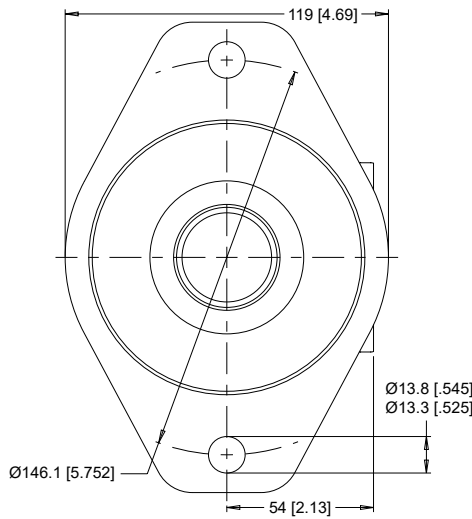

**4-HOLE, WHEEL MOUNT**

**W8** Side Ports - 5" Pilot

**Z8** Side Ports - 125mm Pilot

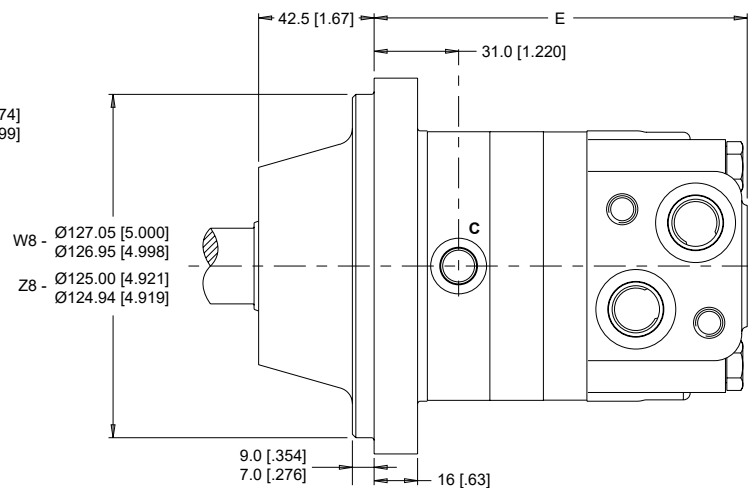
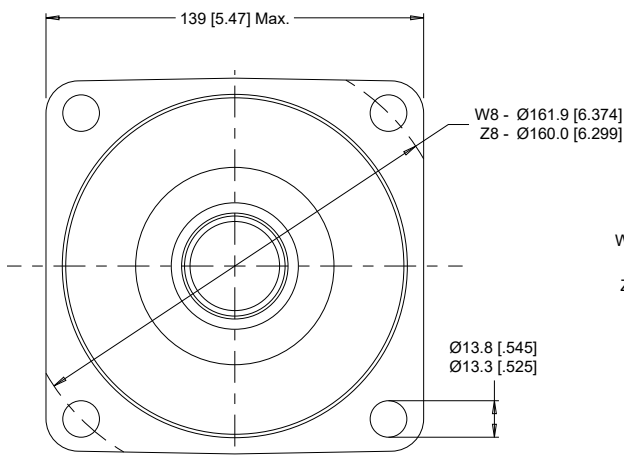

► Dimension C, D & E are charted on page 40.

**TECHNICAL INFORMATION**

**ALLOWABLE SHAFT LOAD / BEARING CURVE**

The bearing curve represents allowable bearing loads for a B10 life of 2,000 hours at 100 rpm. Radial loads for speeds other than 100 rpm may be calculated using the multiplication factor table on page 7.

**SAE A, SAE B & MAGNETO MOUNTS**

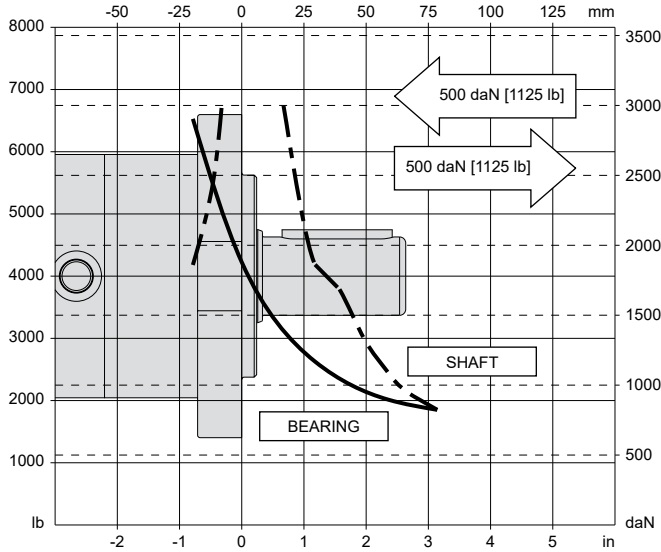

**SQUARE EURO MOUNT**

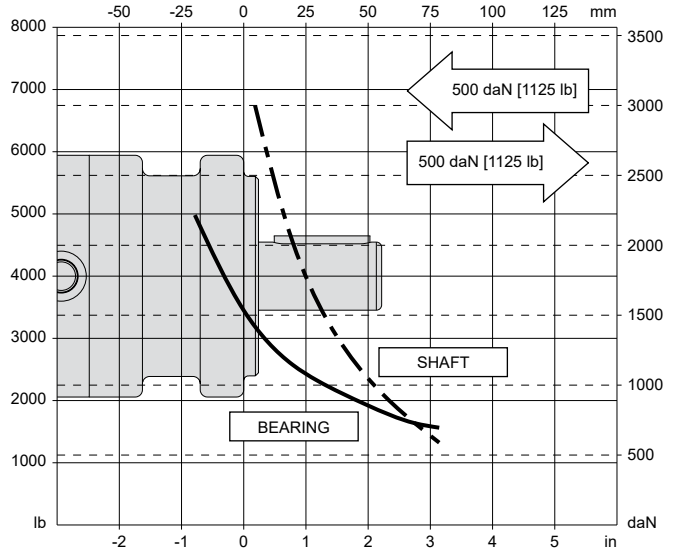

**WHEEL MOUNTS**

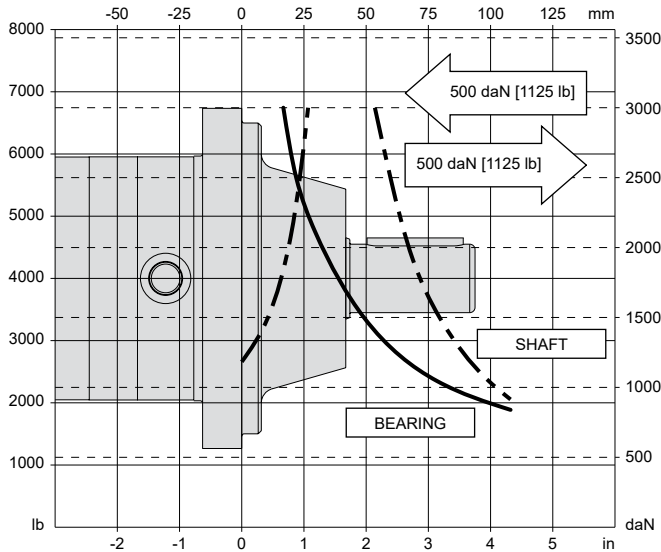

► Case pressure will push outward on the shaft. If case drain line is attached and routed directly to tank, case pressure should be negligible. If case drain line is not attached, case pressure will be nearly the same as motor return pressure. When case pressure is acting, the allowable inward axial load can be increased and the allowable outward axial load must be decreased at a rate of 88 kg / 7 bar [194 lb / 100 psi].

**TECHNICAL INFORMATION**

**PERMISSIBLE SHAFT SEAL PRESSURE**

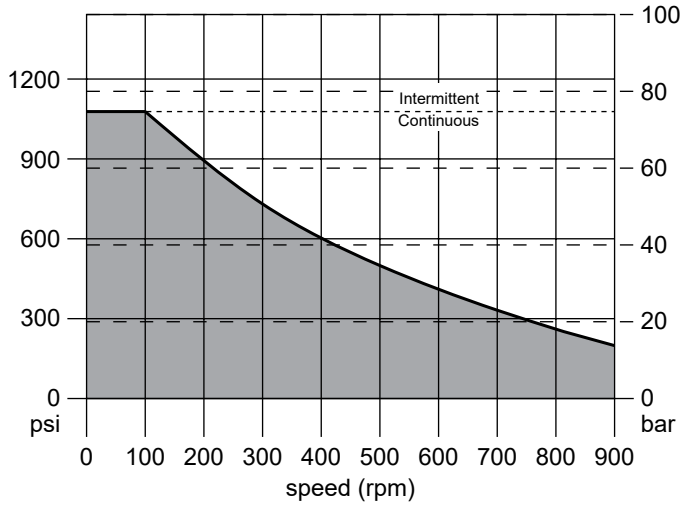

**LENGTH & WEIGHT CHARTS**

The following charts list the overall motor length from the rear of the motor to the mounting flange surface and are referenced on detailed housing drawings listed on pages 37 & 38.

#	Length [mm [in]]	Weight [kg [lb]]
080	170 [6.69]	10.2 [22.5]
100	174 [6.85]	10.5 [23.2]
125	174 [6.85]	10.5 [23.2]
160	180 [7.09]	11.0 [24.3]
200	186 [7.32]	11.4 [25.1]
230	200 [7.87]	12.2 [26.9]
250	193 [7.60]	11.9 [26.2]
315	203 [8.00]	12.4 [27.3]
400	218 [8.58]	13.3 [29.3]
500	233 [9.17]	14.2 [31.3]

#	Length [mm [in]]	Weight [kg [lb]]
080	173 [6.81]	10.2 [22.5]
100	177 [6.97]	10.5 [23.2]
125	177 [6.97]	10.5 [23.2]
160	183 [7.20]	11.0 [24.3]
200	189 [7.44]	11.4 [25.1]
230	203 [7.99]	12.2 [26.9]
250	197 [7.76]	11.9 [26.2]
315	207 [8.15]	12.4 [27.3]
400	221 [8.70]	13.3 [29.3]
500	236 [9.29]	14.2 [31.3]

#	Length [mm [in]]	Weight [kg [lb]]
080	178 [7.01]	10.1 [22.3]
100	182 [7.17]	10.4 [22.9]
125	182 [7.17]	10.4 [22.9]
160	187 [7.36]	10.9 [24.0]
200	194 [7.64]	11.3 [24.9]
230	208 [8.19]	12.1 [26.7]
250	201 [7.91]	11.8 [26.0]
315	211 [8.31]	12.3 [27.1]
400	225 [8.86]	13.2 [29.1]
500	240 [9.45]	14.1 [31.1]

#	Length [mm [in]]	Weight [kg [lb]]
080	166 [6.54]	11.2 [24.7]
100	170 [6.69]	11.5 [25.4]
125	170 [6.69]	11.5 [25.4]
160	176 [6.93]	12.0 [26.5]
200	182 [7.17]	12.4 [27.3]
230	196 [7.72]	13.2 [29.1]
250	190 [7.48]	12.9 [28.4]
315	200 [7.87]	13.4 [29.5]
400	214 [8.43]	14.3 [31.5]
500	229 [9.02]	15.2 [33.5]

#	Length [mm [in]]	Weight [kg [lb]]
080	133 [5.24]	11.0 [24.3]
100	137 [5.39]	11.3 [24.9]
125	137 [5.39]	11.3 [24.9]
160	143 [5.63]	11.8 [26.0]
200	149 [5.87]	12.2 [26.9]
230	163 [6.42]	13.0 [28.7]
250	157 [6.18]	12.7 [28.0]
315	167 [6.57]	13.2 [29.1]
400	181 [7.13]	14.1 [31.1]
500	196 [7.72]	15.0 [33.1]

► 360 series motor weights can vary ± 1kg [2 lb] depending on model configurations such as housing, shaft, endcover, options etc.

**PORTING**

**SIDE PORTED -  
OFFSET MANIFOLD**

**1** Main Ports **A, B:** 7/8-14 UNF  
Drain Port **C:** 7/16-20 UNF

**3** Main Ports **A, B:** G 1/2  
Drain Port **C:** G 1/4

**4** Main Ports **A, B:** M22x1.5  
Drain Port **C:** M14x1.5

**STANDARD**

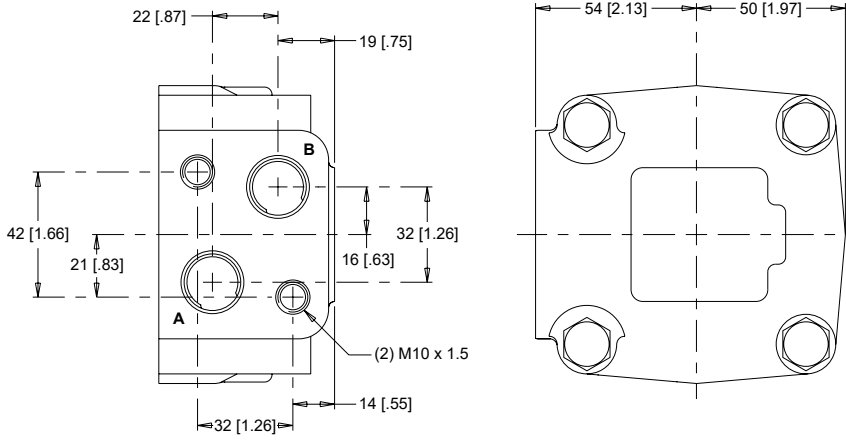

► Drain port C is referenced on housing drawings listed on pages 37, 38 and 44.

**SHAFTS**

**10** 1" Straight

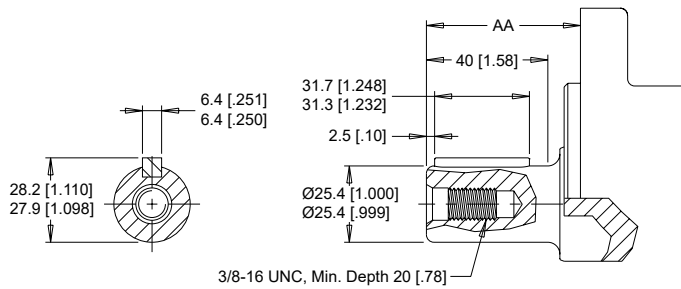

Max. Torque: 655 Nm [5800 lb-in]

**12** 25mm Straight

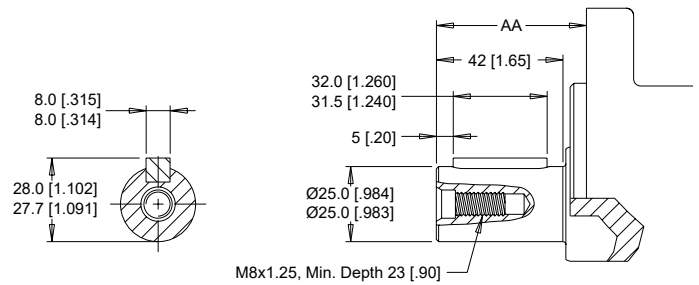

Max. Torque: 678 Nm [6000 lb-in]

**20** 1-1/4" Straight

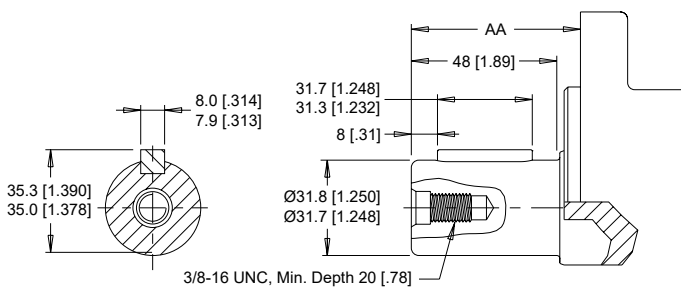

Max. Torque: 881 Nm [7800 lb-in]

**21** 32mm Straight

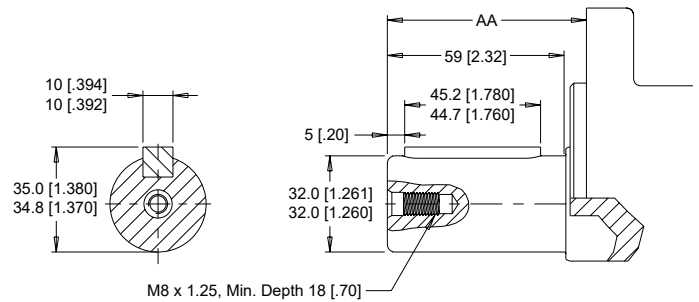

Max. Torque: 881 Nm [7800 lb-in]

**23** 14 Tooth Spline

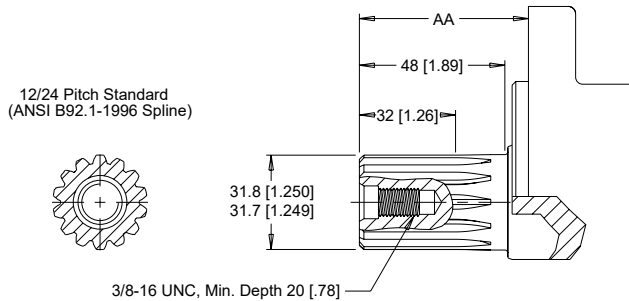

Max. Torque: 881 Nm [7800 lb-in]

**78** 1-3/8" 6B Spline PTO

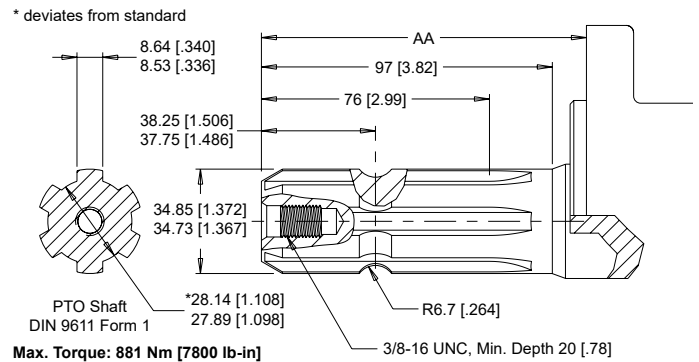

Max. Torque: 881 Nm [7800 lb-in]

► Dimension AA is charted on page 43.

**SHAFTS**

**N4** 35mm Tapered

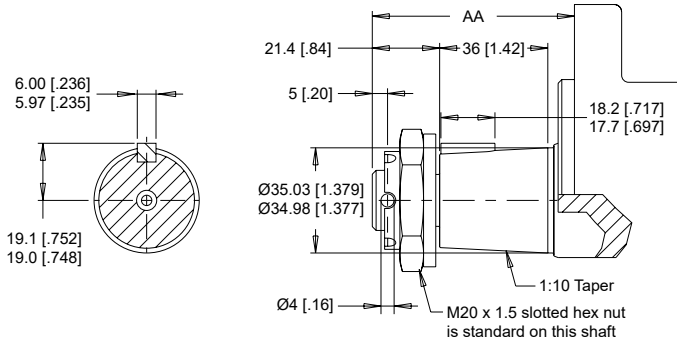

Max. Torque: 881 Nm [7800 lb-in]

**31** 1-1/2" Tapered

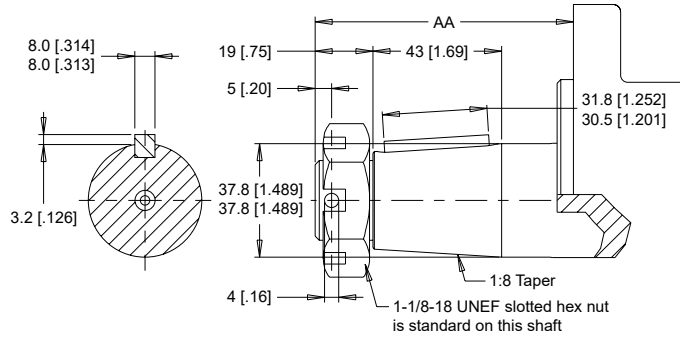

Max. Torque: 881 Nm [7800 lb-in]

**G4** 1" 6B Spline

SAE 6 B  
B.S.2059 STANDARD

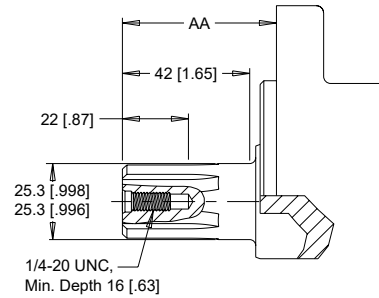
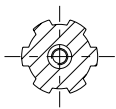

Max. Torque: 678 Nm [6000 lb-in]

**N3** 1-1/4" 14 Tooth Spline

12/24 Pitch Standard  
(ANSI B92.1-1970 Spline)

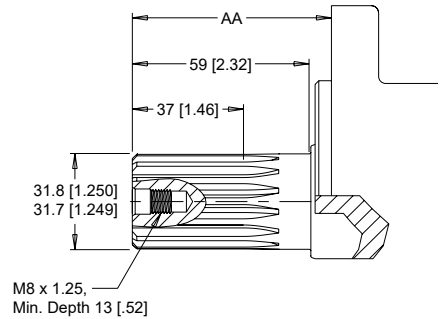
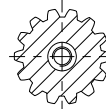

Max. Torque: 881 Nm [7800 lb-in]

**N5** 1-1/4" Tapered

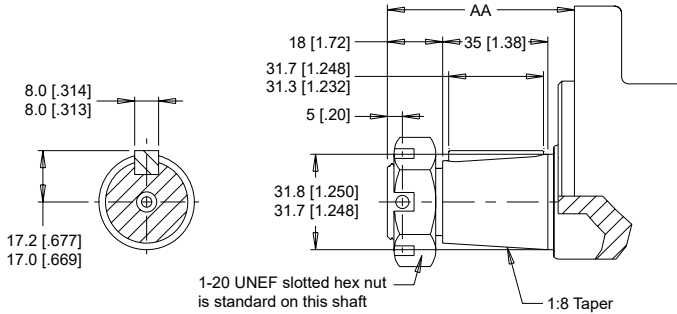

Max. Torque: 881 Nm [7800 lb-in]

**MOUNTING / SHAFT LENGTH CHART**

Dimension AA is the overall distance from the motor mounting surface to the end of the shaft and is referenced on detailed shaft drawings above as well as shafts on page 42.

AA	SAE A Mounts	Magneto Mounts	Sq. Euro Mounts	SAE B Mounts	Wheel Mounts
#	mm [in]	mm [in]	mm [in]	mm [in]	mm [in]
10	52 [2.05]	48 [1.89]	44 [1.73]	55 [2.17]	88 [3.46]
12	51 [2.01]	47 [1.85]	43 [1.69]	54 [2.13]	87 [3.43]
20	57 [2.24]	53 [2.09]	49 [1.93]	60 [2.36]	93 [3.66]
21	67 [2.63]	63 [2.48]	59 [2.32]	70 [2.76]	103 [4.06]
23	57 [2.24]	53 [2.09]	49 [1.93]	60 [2.36]	93 [3.66]
31	86 [3.39]	83 [3.27]	79 [3.11]	90 [3.54]	123 [4.84]
78	109 [4.29]	105 [4.13]	101 [3.98]	112 [4.41]	145 [5.71]
G4	52 [2.05]	48 [1.89]	44 [1.73]	55 [2.17]	88 [3.46]
N3	67 [2.63]	63 [2.48]	59 [2.32]	70 [2.76]	103 [4.06]
N4	67 [2.63]	63 [2.48]	59 [2.32]	70 [2.76]	103 [4.06]
N5	63 [2.48]	59 [2.32]	55 [2.17]	66 [2.60]	99 [3.90]

▶ Shaft lengths vary ± 0.8 mm [0.030 in.]

# WS (360 Series)

## Heavy Duty Hydraulic Short Motor

### HOUSINGS

#### 4-HOLE, SHORT MOTOR MOUNT

**SH** Side Ports

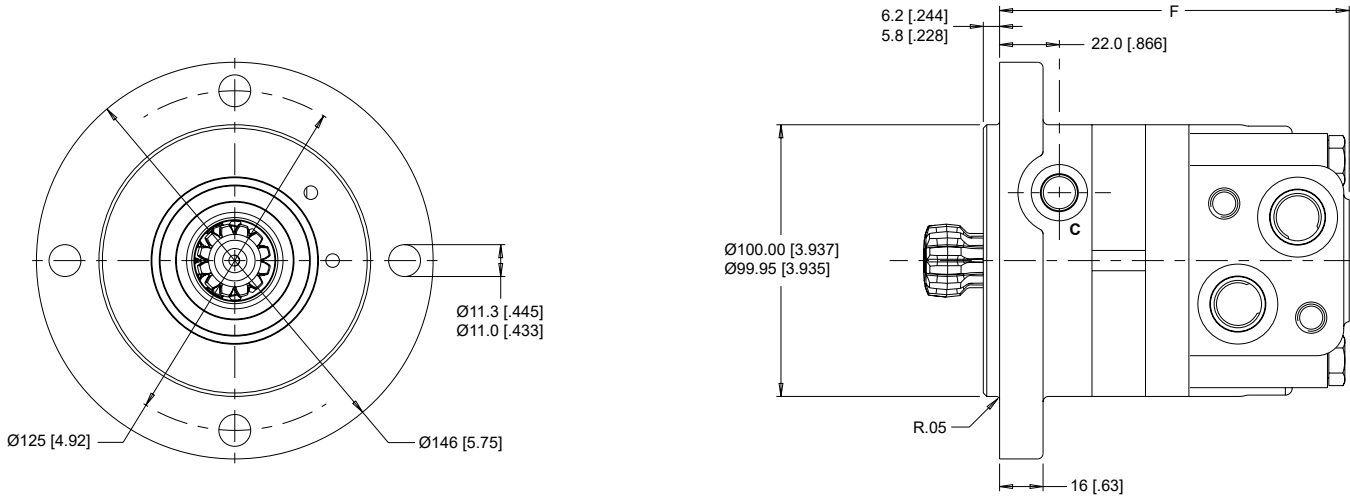

► Porting options listed on page 41.

### SHAFTS

#### 00 Cardan (For Use With The SH Mount)

Fillet Root Side Fit	
Number of Teeth	12
Pitch	12/24
Pressure Angle	30°
Pitch Diameter <i>D</i>	25.4 [1.000]
Major Diameter <i>D<sub>ri</sub></i>	28.0 [1.10] - 27.9 [1.096]
Form Diameter (Min.) <i>D<sub>fi</sub></i>	27.6 [1.09]
Minor Diameter <i>D<sub>i</sub></i>	23.033 [.9068] - 23.0 [.9055]
Space Width (Circular) <i>L<sub>o</sub>*</i>	4.328 [.1704] - 4.288 [.1688]
Tooth Thickness (Circular) <i>S<sub>o</sub></i>	2.341 [.09217]
Fillet Radius <i>R</i> min	0.2 [.008]
Max. Distance Between Pins <i>l</i>	17.77 [.700] - 17.62 [.694]
Pin Diameter <i>d</i>	4.836 [.19034] - 4.834 [.19026]

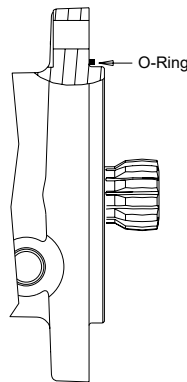

Internal involute spline data per ANSI B92.1-1970, class 5 (corrected  $m \cdot X = 0.8$ ;  $m = 2.1166$ )

► The recommended shaft material is SAE 8620 or similar case hardening steel such as 20 MoCr4 (900 N/mm<sup>2</sup>) hardened to 59 - 62 HRC to a depth of 0.762 - 1.016 [.030 - .040].  
\*Dimensions apply after heat treatment.

#### INPUT DIMENSIONS

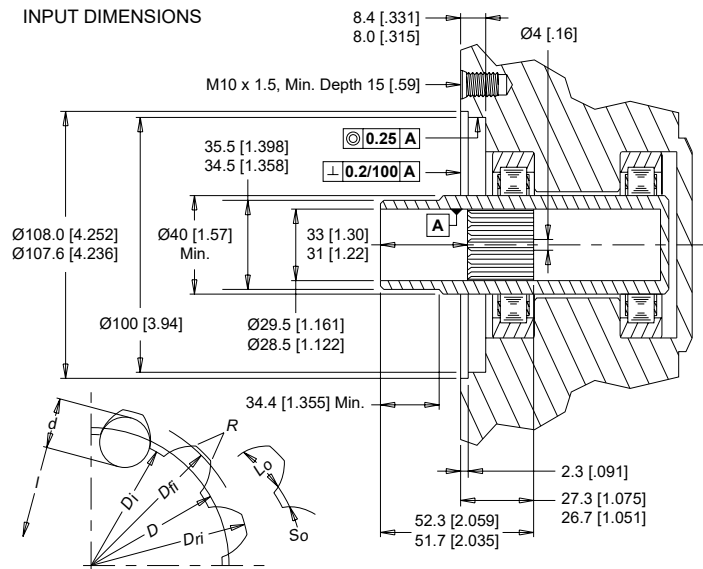

### LENGTH & WEIGHT CHART

Dimension F is the overall motor length from the rear of the motor to the mounting flange surface and is referenced on the detailed housing drawing listed above.

F	Length	Weight
#	mm [in]	kg [lb]
080	125 [4.92]	7.8 [17.2]
100	129 [5.08]	8.1 [17.9]
125	129 [5.08]	8.1 [17.9]
160	134 [5.28]	8.6 [19.0]
200	141 [5.55]	9.0 [19.8]
230	155 [6.10]	9.8 [21.6]
250	148 [5.83]	9.5 [20.9]
315	158 [6.22]	10.0 [22.0]
400	173 [6.81]	10.9 [24.0]
500	188 [7.40]	11.8 [26.0]

► 360 series short motor weights can vary ± 1kg [2 lb] depending on model configurations such as housing, shaft, endcover, options etc.

**HOUSINGS**

**4-HOLE, ULTRA SHORT MOTOR MOUNT**

**U8** Side Ports

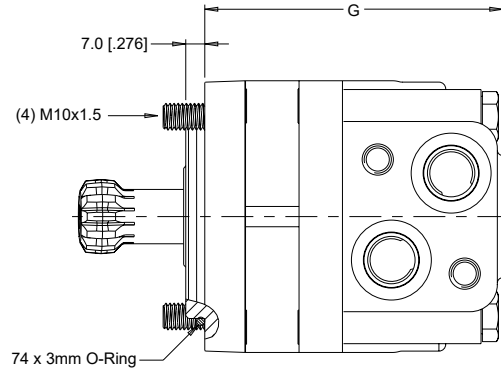
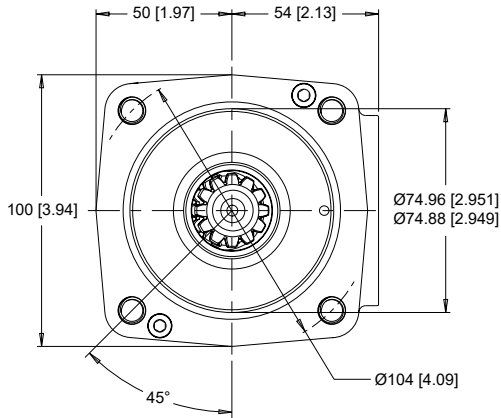

► Porting options listed on page 41.

**SHAFTS**

**00** Cardan (For Use With The U8 Mount)

Fillet Root Side Fit	
Number of Teeth	12
Pitch	12/24
Pressure Angle	30°
Pitch Diameter <i>D</i>	25.4 [1.000]
Major Diameter <i>D<sub>ri</sub></i>	28.0 [1.10] - 27.9 [1.096]
Form Diameter (Min.) <i>D<sub>fi</sub></i>	27.6 [1.09]
Minor Diameter <i>D<sub>i</sub></i>	23.033 [0.9068] - 23.0 [0.9055]
Space Width (Circular) <i>L<sub>o</sub></i>	4.328 [0.1704] - 4.288 [0.1688]
Tooth Thickness (Circular) <i>S<sub>o</sub></i>	2.341 [0.09217]
Fillet Radius <i>R</i> min	0.2 [0.008]
Max. Distance Between Pins <i>l</i>	17.77 [0.700] - 17.62 [0.694]
Pin Diameter <i>d</i>	4.836 [0.19034] - 4.834 [0.19026]

Internal involute spline data per ANSI B92.1-1970, class 5 (corrected  $m \cdot X = 0.8$ ;  $m = 2.1166$ )

► The recommended shaft material is SAE 8620 or similar case hardening steel such as 20 MoCr4 (900 N/mm<sup>2</sup>) hardened to 59 - 62 HRC to a depth of 0.762 - 1.016 [0.030 - .040].  
\*Dimensions apply after heat treatment.

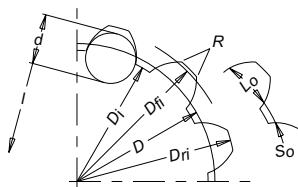

**LENGTH & WEIGHT CHART**

Dimension G is the overall motor length from the rear of the motor to the mounting flange surface and is referenced on the detailed housing drawing listed above.

G	Length	Weight
#	mm [in]	kg [lb]
080	106 [4.16]	6.3 [13.9]
100	110 [4.32]	6.6 [14.6]
125	110 [4.32]	6.6 [14.6]
160	115 [4.54]	7.1 [15.7]
200	122 [4.79]	7.5 [16.5]
250	129 [5.09]	8.0 [17.6]

► 360 series ultra short motor weights can vary ± 1kg [2 lb] depending on model configurations such as housing, shaft, endcover, options etc.

**INPUT DIMENSIONS**

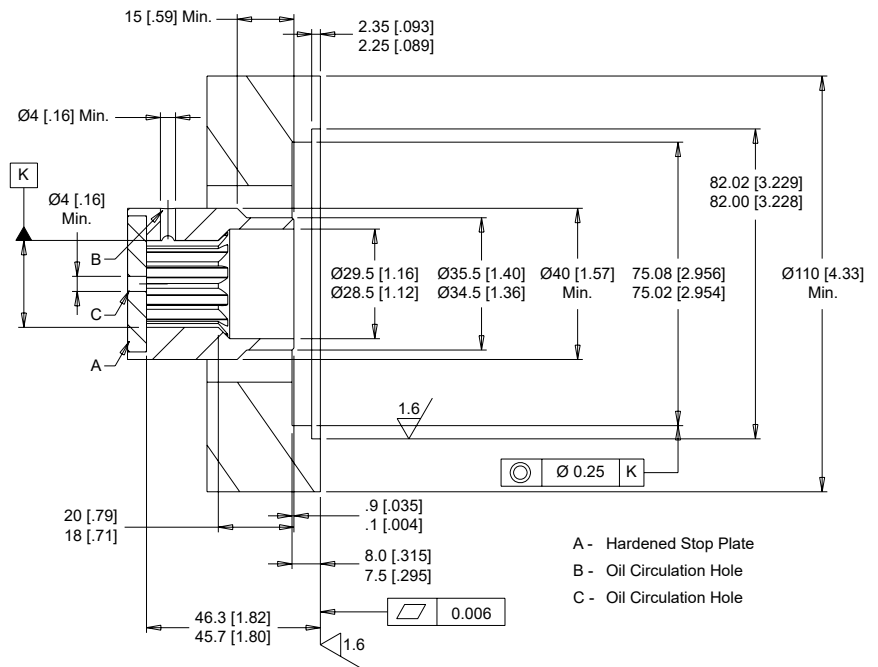

- A - Hardened Stop Plate
- B - Oil Circulation Hole
- C - Oil Circulation Hole

# WS (360 Series)

## Heavy Duty Hydraulic Ultra Short Motor

### HOUSINGS

#### 4-HOLE, ULTRA SHORT MOTOR MOUNT

**V8** Side Ports

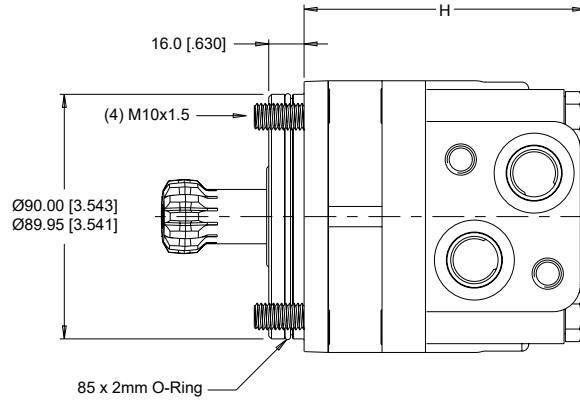
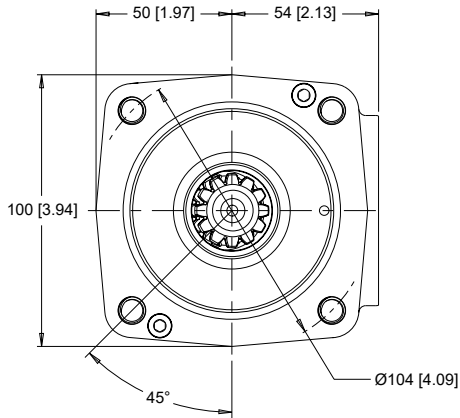

► Porting options listed on page 41.

### SHAFTS

#### 00 Cardan (For Use With The V8 Mount)

Fillet Root Side Fit

Number of Teeth	12
Pitch	12/24
Pressure Angle	30°
Pitch Diameter $D$	25.4 [1.000]
Major Diameter $D_{rj}$	28.0 [1.10] - 27.9 [1.096]
Form Diameter (Min.) $D_{fi}$	27.6 [1.09]
Minor Diameter $D_i$	23.033 [9068] - 23.0 [9055]
Space Width (Circular) $L_o^*$	4.328 [1.704] - 4.288 [1.688]
Tooth Thickness (Circular) $S_o$	2.341 [0.9217]
Fillet Radius $R$ min	0.2 [0.008]
Max. Distance Between Pins $l$	17.77 [700] - 17.62 [694]
Pin Diameter $d$	4.836 [1.9034] - 4.834 [1.9026]

Internal involute spline data per ANSI B92.1-1970, class 5 (corrected  $m \cdot X = 0.8$ ;  $m = 2.1166$ )

► The recommended shaft material is SAE 8620 or similar case hardening steel such as 20 MoCr4 (900 N/mm<sup>2</sup>) hardened to 59 - 62 HRC to a depth of 0.762 - 1.016 [0.030 - .040].  
\*Dimensions apply after heat treatment.

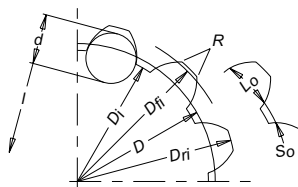

#### INPUT DIMENSIONS

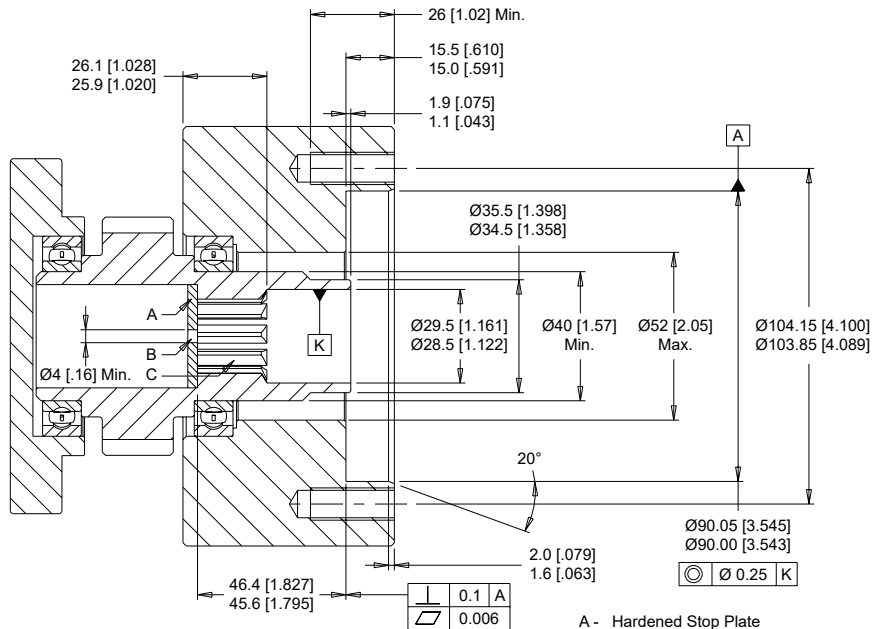

- A - Hardened Stop Plate
- B - Oil Circulation Hole
- C - Internal Spline  
Dp 12/24 ANSI B92.1-76

### LENGTH & WEIGHT CHART

Dimension H is the overall motor length from the rear of the motor to the mounting flange surface and is referenced on the detailed housing drawing listed above.

H	Length	Weight
#	mm [in]	kg [lb]
080	100 [3.92]	6.3 [13.9]
100	104 [4.08]	6.6 [14.6]
125	104 [4.08]	6.6 [14.6]
160	109 [4.31]	7.1 [15.7]
200	116 [4.56]	7.5 [16.5]
250	123 [4.86]	8.0 [17.6]

► 360 series ultra short motor weights can vary  $\pm$  1kg [2 lb] depending on model configurations such as housing, shaft, endcover, options etc.

**ORDERING INFORMATION**

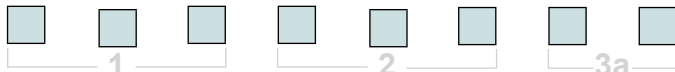

**1. CHOOSE SERIES DESIGNATION**

**360** Clockwise Rotation

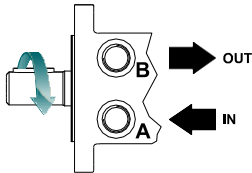

► The 360 series is bi-directional. Reversing the inlet hose will reverse shaft rotation.

**2. SELECT A DISPLACEMENT OPTION**

<b>080</b>	80 cm <sup>3</sup> /rev [4.9 in <sup>3</sup> /rev]	<b>230</b>	226 cm <sup>3</sup> /rev [13.8 in <sup>3</sup> /rev]
<b>100</b>	100 cm <sup>3</sup> /rev [6.1 in <sup>3</sup> /rev]	<b>250</b>	250 cm <sup>3</sup> /rev [15.2 in <sup>3</sup> /rev]
<b>125</b>	125 cm <sup>3</sup> /rev [7.6 in <sup>3</sup> /rev]	<b>315</b>	305 cm <sup>3</sup> /rev [18.6 in <sup>3</sup> /rev]
<b>160</b>	160 cm <sup>3</sup> /rev [9.7 in <sup>3</sup> /rev]	<b>400</b>	393 cm <sup>3</sup> /rev [24.0 in <sup>3</sup> /rev]
<b>200</b>	200 cm <sup>3</sup> /rev [12.2 in <sup>3</sup> /rev]	<b>500</b>	493 cm <sup>3</sup> /rev [30.1 in <sup>3</sup> /rev]

**3a. SELECT MOUNT TYPE**

▼ **SIDE MOUNT**

<b>A7</b>	2-Hole, SAE A Mount
<b>AT</b>	6-Hole, Magneto Mount
<b>AH</b>	4-Hole, SAE A Mount
<b>AU</b>	4-Hole, Square Euro Mount
<b>B7</b>	2-Hole, SAE B Mount
<b>SH</b>	4-Hole, Short Motor Mount
<b>U8</b>	4-Hole, Ultra Short (75mm Pilot)
<b>V8</b>	4-Hole, Ultra Short (90mm Pilot)
<b>W8</b>	4-Hole, Wheel Mount (5" Pilot)
<b>Z8</b>	4-Hole, Wheel Mount (125mm Pilot)

**3b. SELECT PORT SIZE**

▼ **SIDE PORT OPTIONS**

<b>1</b>	7/8-14 UNF Offset Manifold
<b>3</b>	G 1/2 Offset Manifold
<b>4</b>	M22x1.5 Offset Manifold

► The SH, U8 and V8 Mounts are only available with the 00 cardan shaft



**4. SELECT A SHAFT OPTION**

<b>00</b>	Cardan	<b>31</b>	1-1/2" Tapered
<b>10</b>	1" Straight	<b>78</b>	1-3/8" 6B Spline PTO
<b>12</b>	25mm Straight	<b>G4</b>	1" 6B Spline
<b>20</b>	1-1/4" Straight	<b>N3</b>	14 Tooth Spline, M8 Tap
<b>21</b>	32mm Straight	<b>N4</b>	35mm Tapered
<b>23</b>	14 Tooth Spline, 3/8" Tap	<b>N5</b>	1-1/4" Tapered

► The cardan shaft is only available with the SH, U8 and V8 Mounts.

**5. SELECT A PAINT OPTION**

<b>A</b>	Black
<b>B</b>	Black, Unpainted Mounting Surface
<b>Z</b>	No Paint

► The SH, U8 and V8 mounts are only available with no paint.

**6. SELECT A VALVE CAVITY / CARTRIDGE OPTION**

<b>A</b>	None
----------	------

**7. SELECT AN ADD-ON OPTION**

<b>A</b>	Standard
----------	----------

**8. SELECT A MISCELLANEOUS OPTION**

<b>AA</b>	None
-----------	------