

1CER90 - Overcenter valve

Part balanced, pilot assisted relief with check
 90 L/min (23 USgpm) • 270 bar (4000 psi)

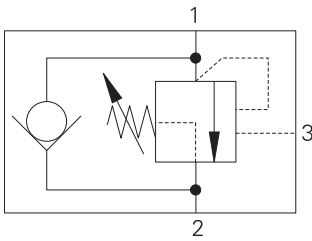

Sectional view

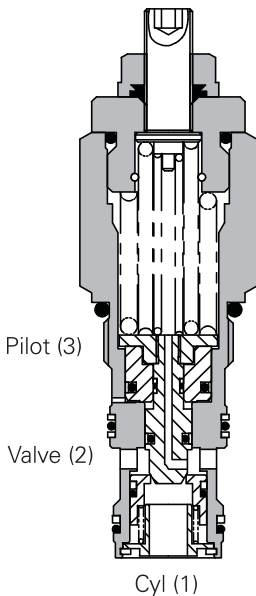

Operation

The check section allows free flow into the actuator then holds and locks the load against movement. The pilot assisted relief valve section will give controlled movement when pilot pressure is applied. The relief section is normally set to open at a pressure at least 1.3 times the maximum load induced pressure but the pressure required to open the valve and allow movement

depends on the pilot ratio of the valve. For optimization of load control and energy usage, a choice of pilot ratios is available.

The pressure required to open the valve and start actuator movement can be calculated as follows:

$$\text{Pilot Pressure} = \frac{(\text{Relief Setting}) - (\text{Load Pressure})}{\text{Pilot Ratio}}$$

Features

Cartridge is economical and fits simple cavity. Allows quick, easy field service - reduces down time. Interchangeable with pilot check valve of a similar size.

Pilot ratio

4:1 Best suited for applications where load varies and machine structure can induce instability.

Other ratios available upon request.

Performance data

Ratings and specifications

Figures based on: Oil Temp = 40°C Viscosity = 32 cSt (150 SUS)

Rated flow	90 L/min (23 USgpm)
Max relief pressure	350 bar (5000 psi)
Max load induced pressure	270 bar (4000 psi)
Cartridge material	Working parts hardened and ground steel. External surfaces zinc plated.
Standard housing materials	Aluminum up to 210 bar. Add suffix "377" for steel option.
Cavity	A12336 (see Section M)
Mounting position	Unrestricted
Torque cartridge into cavity	60 Nm (44 lbs ft)
Weight	1CER90 29 kg (.63 lbs) 1CER95 1.35 kg (2.97 lbs) 1CEER95 2.10 kg (4.62 lbs)
Seal kit	SK633 (Nitrile) SK633V (Viton®)
Filtration	BS5540/4 Class 18/13 (25 micron nominal)
Temperature range	-30° to +90°C (-22° to +194°F)
Internal leakage	0.3 ml/min (5 dpm)
Nominal viscosity range	5 to 500 cSt

Viton is a registered trademark of E.I. DuPont.

Pressure drop

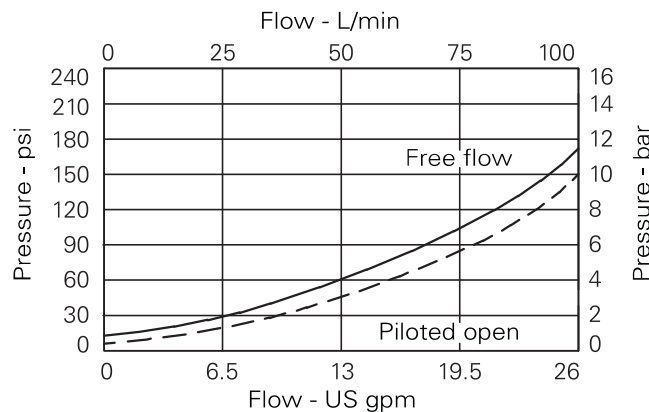

Description

The 1CER series overcenter valve performs all duties of a regular overcenter but is able to relieve and stay open irrespective of downstream pressure. This enables the valve to operate when used with a closed center directional valve which has service line reliefs. The poppet is pressure balanced, preventing relief setting increase due to back pressure.

Where measurements are critical request certified drawings. We reserve the right to change specifications without notice.

ICER90 - Overcenter valve

Part balanced, pilot assisted relief with check
90 L/min (23 USgpm) • 270 bar (4000 psi)

Model code

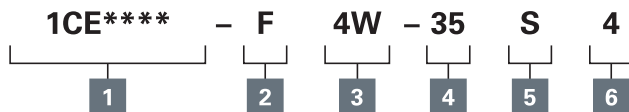

1 Function

- 1CER90 - Cartridge only
- 1CER95 - Cartridge and body
- 1CEER95 - Cartridges and body

2 Adjustment

- F - Screw adjustment
 - N - Fixed - State pressure setting required.
- For fixed versions add setting in 10 bar increments to end of part number. Subject to a +/-10% tolerance.

Dimensions

mm (inch)

Cartridge only

Basic Code

1CER90

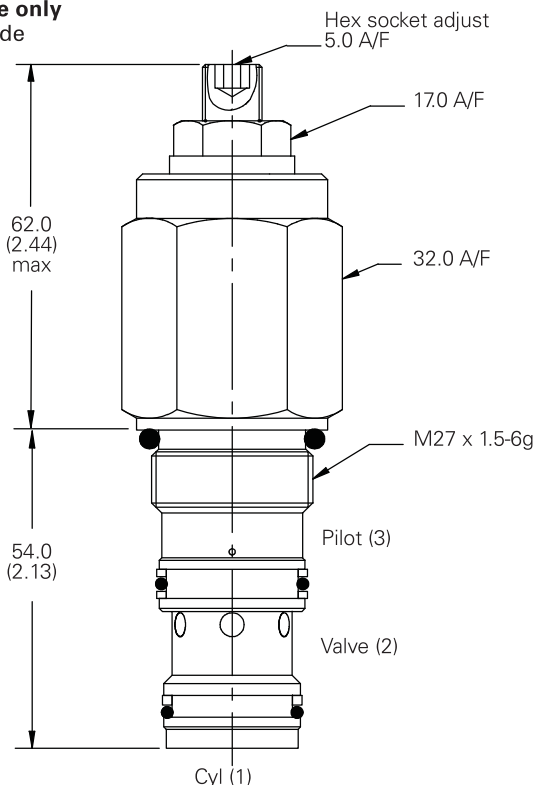

Note: For applications above 210 bar - please consult our technical department or use the steel body option.

Note: Tightening torque of "F" adjuster locknut - 20 to 25 Nm.

3 Port size

Code	Port size	Housing number - body only			
		Aluminum single	Steel single	Aluminum dual	Steel dual
4W	1/2" BSP Valve & Cyl Port 1/4" BSP Pilot Port	B13625	B13626	C13627	C13628
8T	1/2" SAE Valve & Cyl Port 1/4" SAE Pilot Port	B10806	B10922	C10807	C11561

4 Pressure range @ 4.8 L/min

Note: Code based on pressure in bar.

20 - 70-225 bar.
Std setting 100 bar

35 - 200-350 bar.
Std setting 210 bar

Std setting made at 4.8 L/min

5 Seal material

S - Nitrile (For use with most industrial hydraulic oils)

SV - Viton (For high temperature and most special fluid applications)

6 Pilot ratio

4 - 4:1 Other ratios available upon request

Single valve

1/2" Ports

Basic Code

1CER95

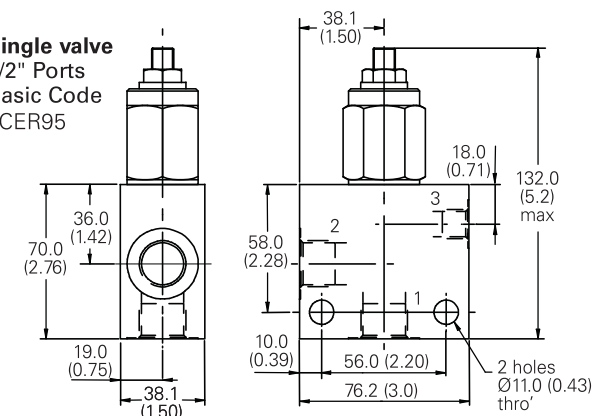

Dual valve

1/2" Ports

Basic Code 1CEER95

Internally Cross Piloted

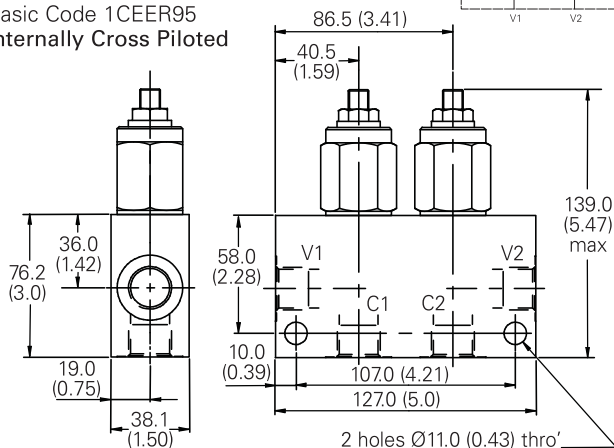

Where measurements are critical request certified drawings. We reserve the right to change specifications without notice.