



FUEL MANAGEMENT SYSTEMS



DISPENSERS



KITS



PUMPS



METERS



NOZZLES

VISCOMAT VANE

FEATURES

- VERSATILITY
- MOBILE AND READY TO USE
- MULTIPURPOSE PUMP
- ADJUSTABLE BYPASS

The PIUSI VISCOMAT VANE is an electric vane pump suitable for all those applications where it is necessary to apply a transfer system with high suction capacity in order to transfer fluids with low viscosity up to 500 cSt. The pump is fitted with an asynchronous and self-ventilating motor, closed and available in different voltages and frequencies in order to adapt to any working condition.

PERFORMANCE

UP TO

50 L/MIN

FLOW RATE

AC

POWER

UP TO

500 CST

VISCOSITY



VISCOMAT VANE



PACKAGING

CODE	WEIGHT		PACKAGING			N. BOXES / EUROPALLET	
	KG	LBS	MM	INCH	PCS/BOX	✕	

VISCOMAT 70

FO033490A	14,1	31,1	355X185X285	-	1	60	72
FO033190A	14,1	31,1	350X200X280	-	1	60	72

VISCOMAT 90

FO0303M00	14,1	31,1	350X200X280	-	1	60	72
000303000	14,1	31,1	350X200X280	-	1	60	72



FILTRATION



TANK MONITORING



HOSE REEL



ACCESSORIES



MERCHANDISE



ANY BIODIESEL



AIR



ANTIFREEZE



AdBlue®



BIODIESEL



DIESEL



FOOD



GASOLINE



GREASE



KEROSENE



OIL



WATER



WINDSCREEN

CHART

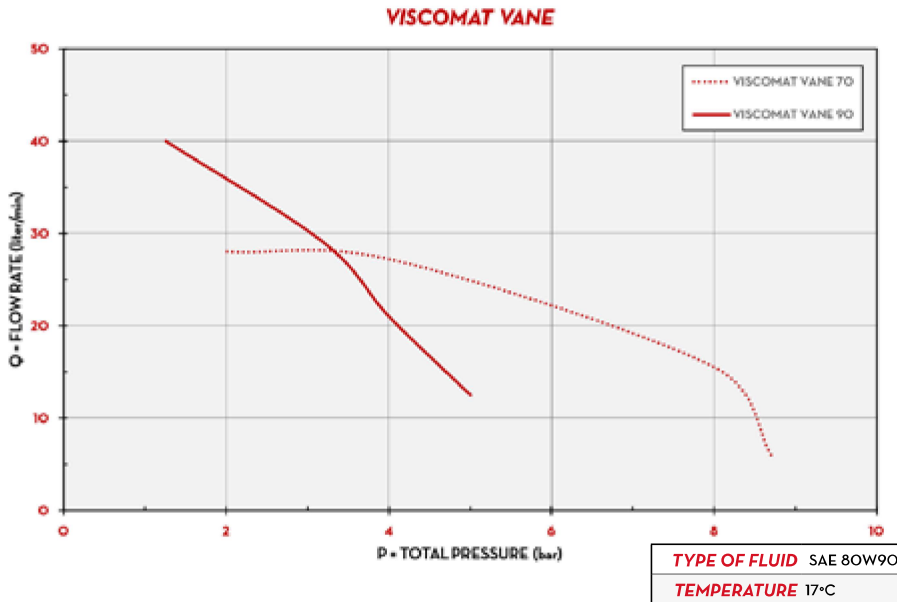

DIMENSIONS

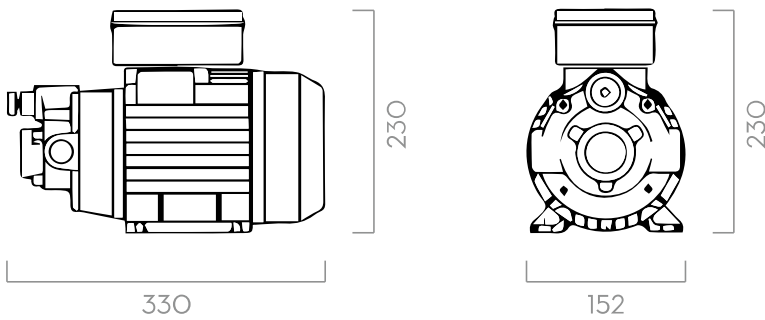

Dimensions expressed in millimeters

IN THE BOX

- VISCOMAT VANE PUMP
- INSTRUCTION MANUAL

DETAILS

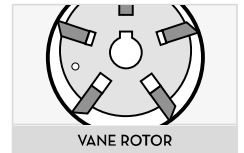

MATERIALS

- BODY: CAST IRON
- ROTOR: SINTERED STEEL
- VANES: TECHNOPOLYMER
- SHAFT: STEEL



PUMP

- SUCTION HOSE Ø 1" MIN,
- MAX SUCTION HEIGHT:
 - 2M (7FT) W/O NO BACK VALVE
 - 4M (14FT) W NO BACK VALVE



TANK

TECHNICAL DATA

CODE	DESCRIPTION	FLUIDS TYPE	FLOW RATE		PRESSURE		VOLTAGE				RPM	INLET/OUTLET	
			L/MIN	GPM	BAR	PSI	SINGLEPHASE MOTOR V./HZ	THREEPHASE MOTOR V./HZ	POWER WATT	AMP. MAX.		BSP	ADJUSTABLE BYPASS VALVE
VISCOMAT 70													
FO033490A	VISCOMAT 70 M 230/50-60	D O B	25	7	6	85	230/50-60	-	1200/1100	5,5 - 5,1	1470/1650	1"	YES
FO033190A	VISCOMAT 70 T 400/50-60	D O B	25	7	6	85	-	400/50 - 400/60	650/1000	2,2 - 3,1	1450/1750	1"	YES
VISCOMAT 90													
FO0303M00	VISCOMAT 90 M 230/50-60	D O B	50	13	5	71	230/50-60	-	1350/1600	6,2 - 4,9	1400/1600	1"	NO
000303000	VISCOMAT 90 T 400/50	D O B	50	13	5	71	-	400/50	2000	5	1450	1"	YES

UPON REQUEST IT IS AVAILABLE WITH DIFFERENT VOLTAGE AND FREQUENCY