

# PRV12-12 - Pressure reducing/relieving valve

Spool, pilot operated  
114 L/min (30 USgpm) • 350 bar (5000 psi)

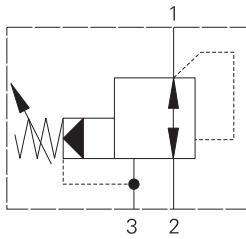

## Operation

This valve is normally open allowing inlet oil to pass to the regulated line until the outlet (regulated) pressure exceeds the setting of the pilot section. When this setting is achieved a pilot flow occurs, causing a pressure imbalance across the main spool, which then moves throttling the inlet flow

and preventing any further pressure rise in the regulated line. If any external force causes the regulated pressure to rise more than 5-10% above the setting, the main spool moves back further, opening the regulated port to the tank line, thus working as a relief valve.

## Features

Cartridge construction with hardened, ground and honed working parts giving smooth, stable operation over all pressure ranges.

## Sectional view

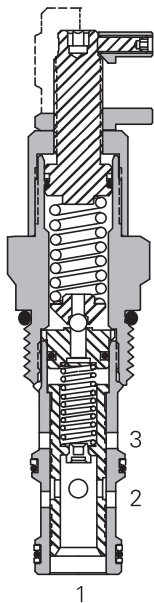

## Performance data

### Ratings and specifications

*Performance data is typical with fluid at 21,8 cSt (105 SUS) and 49° C (120° F)*

|  |   |
|--|---|
| Typical application pressure               | 350 bar (5000 psi) Port 2 to 1 and 1 to 3<br>@ 57 L/min (15 USgpm)                |
|  | 210 bar (3000 psi) Port 2 to 1 @ 114 L/min (30 USgpm)                             |
| Cartridge fatigue pressure (infinite life) | 350 bar (5000 psi)  |
| Rated flow                                 | 114 L/min (30 USgpm)  |
| Internal leakage                           | 1,0 L/min (0.25 USgpm)  |
| Cavity                                     | C-12-3  |
| Standard housing materials                 | Aluminum or steel   |
| Temperature range                          | -40° to 120°C (-40° to 248°F)   |
| Fluids                                     | All general purpose hydraulic fluids such as:<br>MIL-H-5606, SAE 10, SAE 20, etc. |
| Filtration                                 | Cleanliness Code 18/16/13   |
| Weight cartridge only                      | 0,4 kg (0.89 lbs)   |
| Seal kits                                  | 02-165872 Buna-N<br>02-165886 Viton®  |

Viton is a registered trademark of E.I. DuPont

## Description

This is a pilot operated screw in cartridge pressure reducing / relieving valve. The valve maintains a constant outlet pressure in hydraulic sub-systems regardless of fluctuations in the primary system. In addition to this it will act as a relief valve if the pressure in the sub-system rises higher than the setting of the valve directing excess fluid to tank.

## Pressure drop curves

Cartridge only

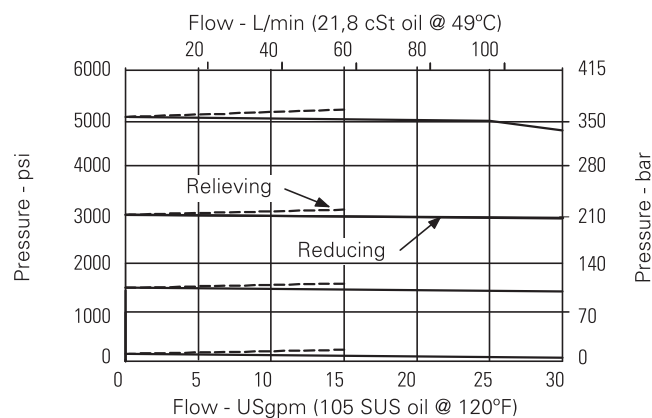

Where measurements are critical request certified drawings. We reserve the right to change specifications without notice.

# PRV12-12 - Pressure reducing/relieving valve

Spool, pilot operated  
114 L/min (30 USgpm) • 350 bar (5000 psi)

## Model code

PRV12 - 12 (V) - \* - (S) - \*\*\* - \*\*/ \*\* - 00

1 2 3 4 5 6 7 8 9

### 1 Function

PRV12 - Pressure reducing/relieving valve

### 2 Size

12 - 12 size

### 3 Seal material

Blank - Buna-N  
V - Viton®

### 4 Adjustment

S - Screw  
C - Cap  
K - Knob

### 5 Valve housing material

Omit for cartridge only

S - Steel  
A - Aluminum

### 6 Port size

0 - Cartridge only

| Code | Port size | Housing number         |                     |
|------|-----------|------------------------|---------------------|
|      |           | Aluminum fatigue rated | Steel fatigue rated |
| 10T  | SAE 10    | 02-160642              | 02-161070           |
| 12T  | SAE 12    | 02-160646              | 02-169816           |
| 4G   | 1/2" BSPP | 02-161817              | 02-169815           |
| 6G   | 3/4" BSPP | 02-161816              | 02-169814           |

See section J for housing.

### 7 Cracking pressure range

Note: Code based on pressure in psi.

15 - 10-100 bar (150-1500 psi)

30 - 17- 210 bar (250-3000 psi)

50 - 24-350 bar (350-5000 psi)

### 8 Factory set reduced pressure

Within ranges in 7

Blank - Normal factory setting at approximate mid-range. User requested settings in 3,45 bar (50 psi) steps, Coded as in the following examples:

10 - 70 bar (1000 psi)

10.5 - 72,4 bar (1050 psi)

### 9 Special features

00 - None

(Only required if valve has special features, omitted if "00.")

## Dimensions

mm (inch)

Torque cartridge in housing

A - 81-95 Nm (60-70 ft. lbs)

S - 102-115 Nm (75-85 ft. lbs)

### Cartridge only

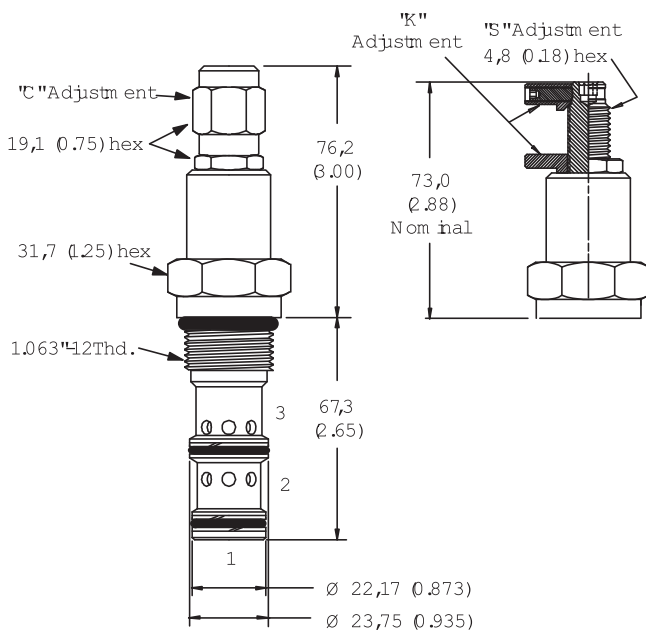

### Installation drawing (Steel)

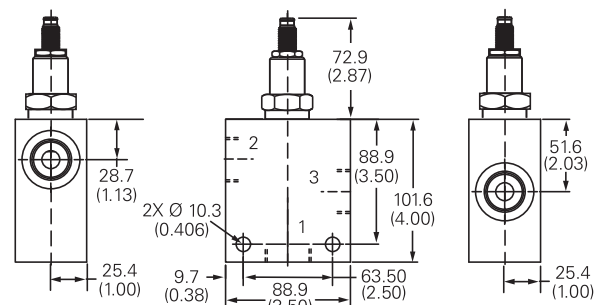

### Warning

Aluminum housings can be used for pressures up to 210 bar (3000 psi). Steel housings must be used for operating pressures above 210 bar (3000 psi).

Where measurements are critical request certified drawings. We reserve the right to change specifications without notice.