

SV13-10-C/CM - Solenoid valve

Poppet type, normally closed solenoid valve, (free reverse flow)
45 L/min (12 USgpm) • 350 bar (5000 psi)

A

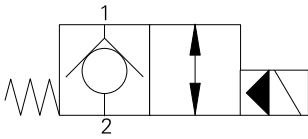

Operation

In the de-energized position the valve blocks flow from port 2 to 1 and free flow is allowed from port 1 to 2.

When the solenoid is energized the pilot poppet is pulled off the seat allowing the valve to open in both directions.

Features

Hardened and ground working parts. Lapped seat for low leakage. IP69K Tough coil compatibility. Continuously rated. Compact design with low pressure drop. 350 bar working pressure.

Sectional view

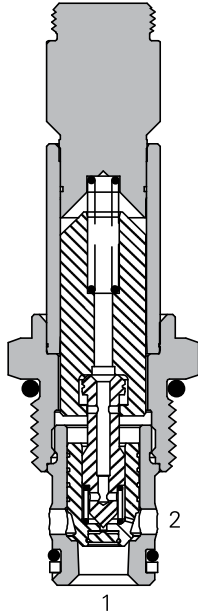

Performance data

Ratings and specifications

Performance data is typical with fluid at 21,8 cSt (105 SUS) and 49°C (120°F)

Typical application pressure (all ports)	350 bar (5000 psi)
Cartridge fatigue pressure (infinite life)	310 bar (4500 psi)
Rated flow	45 L/min (12 USgpm)
Internal leakage, port 2 to port 1	5 drops/min, max @ 350 bar (5000 psi)
Temperature range	-40° to 100°C (-40° to 212°F)
Coil duty	Continuous from 85% to 110% of nominal voltage
Cavity	C-10-2
Fluids	All general purpose hydraulic fluids such as: MIL-H-5606, SAE 10, SAE 20 etc
Filtration	Cleanliness code 18/16/13
Housing material (standard)	Steel
Weight cartridge only	0,18 kg (0.39 lbs)
Seal kit	565803 (Buna-N), 566086 (Viton®)

Viton is a registered trademark of E.I. DuPont

Description

This is a 2-way, 2-position, poppet type, high pressure, pilot operated, normally closed solenoid valve. This valve is used in applications requiring low leakage, such as load holding applications or as a general purpose diverter or dump valve.

Pressure drop

Cartridge only

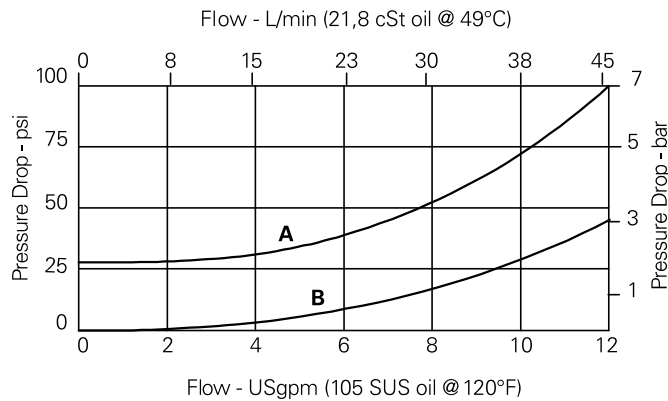

A - Port 1 to port 2

B - Port 2 to port 1 energized

Where measurements are critical request certified drawings. We reserve the right to change specifications without notice.

SV13-10-C/CM - Solenoid valve

Poppet type, normally closed solenoid valve, (free reverse flow)
45 L/min (12 USgpm) • 350 bar (5000 psi)

Model code

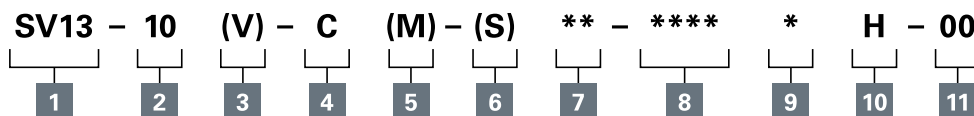

1 Function

SV13 - Solenoid valve

2 Size

10 - 10 size

3 Seal material

Blank - Buna-N

V - Viton®

4 Style

C - Normally closed

5 Manual override option

Blank - No manual override

M - Manual override

For valve dimensions with manual override option installed see page A-980.

6 Valve housing material

Blank - Cartridge only

S - Steel

7 Port size

Code	Port size	Housing number
0	Cartridge only	
2G	1/4" BSPP	02-175102
3G	3/8" BSPP	02-175103
6T	SAE 6	02-175100
8T	SAE 8	02-175101

See section J for housing details.

8 Voltage rating

00 - No coil

12D - 12VDC

24D - 24VDC

36D - 36VDC

24A - 24VAC

115A - 115VAC

230A - 230VAC

12B - 12VDC/w diode*

24B - 24VDC/w diode*

*Optional arc suppression diode.

9 Connector types

Blank - No coil

G - ISO 4400 DIN 43650

Q - Spade terminals

W - Flying lead

N - Deutsch (DC only)

Y - Amp JR (DC only)

D - Metripack 150 male (DC only)

J - Metripack 280 male (DC only)

10 Coil series

H - 10 Series, 29 W

For coil part numbers and dimensions see section C.

11 Special features

00 - None

(Only required if valve has special features, omitted if "00".)

Dimensions

mm (inch)

Torque cartridge in steel housing 68-75 Nm (50-55 ft lbs)

Note: When solenoid valve is ordered as cartridge only, coil nut is included.

Cartridge only

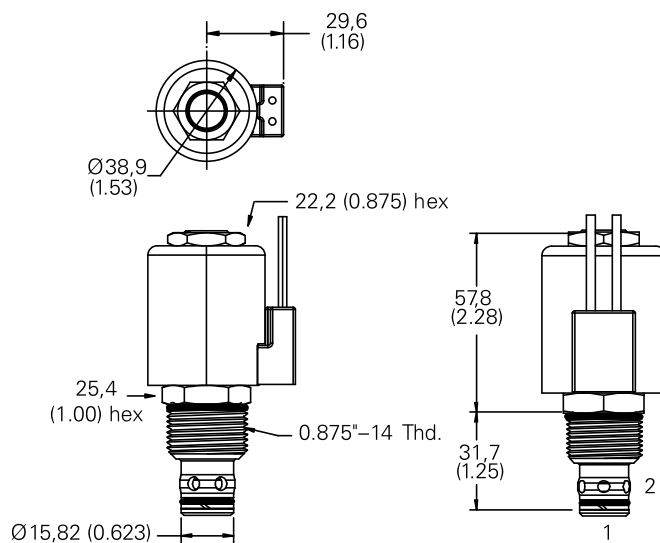

Warning

Maintain 5-8 Nm (4-6 ft lbs) maximum torque on valve tube nut. Over tightening may cause valve failure.

Where measurements are critical request certified drawings. We reserve the right to change specifications without notice.